

# Werkzeugkatalog

tool catalogue

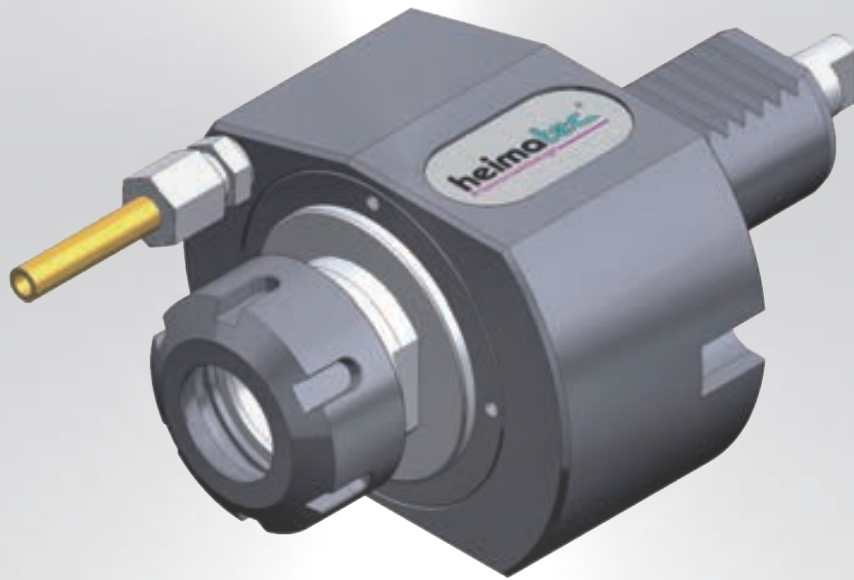

# Hwacheon

VDI 30

CUTEX 160



Hinweis zu den AGBs:

Diese finden Sie in unserem Internetauftritt unter

**[www.heimatec.de](http://www.heimatec.de)**

Home/Impressum/AGB

Terms and conditions:

You will find them on our website

**[www.heimatec.com](http://www.heimatec.com)**

Home/Imprint/Terms and Conditions

Das Katalog-Werk einschließlich aller seiner Teile ist urheberrechtlich geschützt. Jede Verwertung außerhalb der engen Grenzen des Urheberrechtsgesetzes ist ohne Zustimmung der Rechteinhaber unzulässig und strafbar. Das gilt insbesondere für Vervielfältigungen, Übersetzungen, Mikroverfilmungen und die Einspeicherung und Verarbeitung in elektronischen Systemen.

**heimatec® GmbH** behält sich Änderungen technischer Art jederzeit ohne Vorankündigung vor. Dies gilt insbesondere bei Anpassungen an neue oder geänderte internationale Normen oder bei Weiterentwicklungen unserer Produkte oder Herstellungsprozesse.

This catalogue, including all its parts, is protected by copyright. Each use outside the restricted limitations of the Copyright Act is inadmissible and liable to prosecution without the consent of heimatec. This is particularly valid for duplication, translation, microfilming and feeding and processing in electronic systems.

**heimatec® GmbH** reserves the right of technical changes everytime without advance notice, which is particularly valid for adaptations to new or changed international standards, or to developments of our products or manufacturing processes.

angetriebene Werkzeuge  
 driven tools



**Axial-Bohr- und Fräskopf**  
**axial drilling and milling head**

$n_{max} = 6000 \text{ min}^{-1}$

8 010 25 004	ER 25	EK	1:1
8 010 25 044	ER 25	IK 25 bar	1:1
8 010 26 029	easy quick HT 4	EK	1:1
8 010 26 019	easy quick HT 4	IK 25 bar	1:1

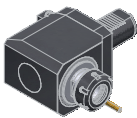

**Winkel-Bohr- und Fräskopf**  
**radial drilling and milling head**

Mittenmaß / center distance  $H=85$   
 $n_{max} = 6000 \text{ min}^{-1}$

8 030 25 222	ER 25	EK	1:1
8 030 25 298	ER 25	IK 140 bar	1:1
8 030 26 156	easy quick HT 4	EK	1:1
8 030 26 157	easy quick HT 4	IK 140 bar	1:1

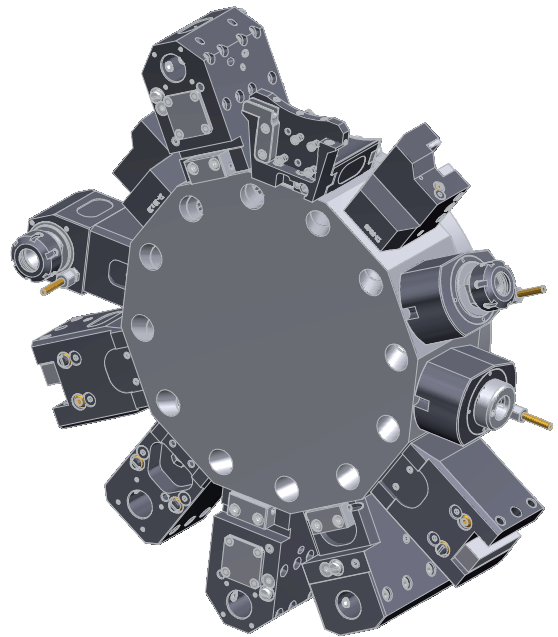

► Weitere Ausführungen auf Anfrage  
 further versions on request

► Zubehör ZB...\*  
 accessories ZB...\*



► easy-quick



► u-tec



**feste Werkzeuge**  
static tool holders



**Kombi-Plandrehalter**  
combi facing holder  
8 234 24 006 **Vierkant/square 20** EK



**Werkzeughalter C2**  
tool holder C2  
*links / left*  
8 215 22 000 **Vierkant/square 20/16** EK



**Werkzeughalter C4**  
tool holder C4  
*links / left*  
8 215 22 001 **Vierkant/square 20/16** EK



**Bohrstangenhalter**  
boring bar holder  
*Mittenmaß / center distance H=85*  
8 230 25 024 **ø16** IK/EK  
8 230 26 041 **ø20** IK/EK  
8 230 27 036 **ø25** IK/EK  
8 230 28 029 **ø32** IK/EK

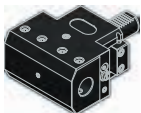

**Doppel-Bohrstangenhalter**  
double boring bar holder  
*Mittenmaß / center distance H=85*  
8 239 27 019 **ø25** IK/EK

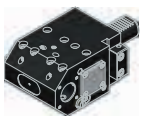

**Doppel-Bohrstangenhalter**  
double boring bar holder  
*Mittenmaß / center distance H=60 / 102*  
8 253 27 019 **ø25** IK/EK

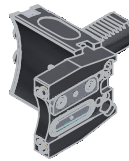
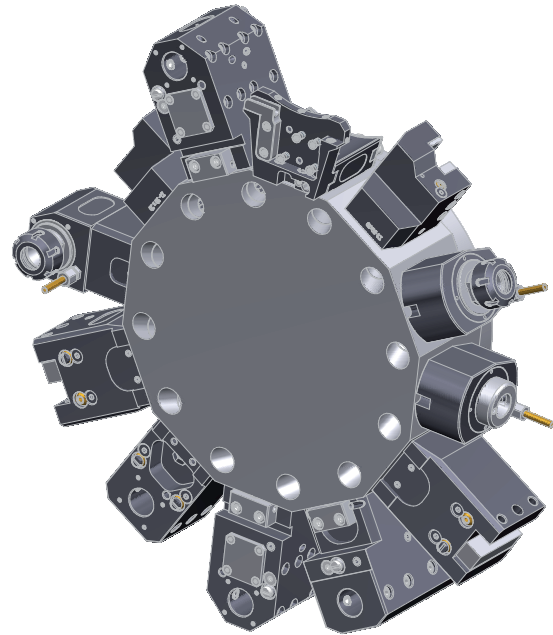

**Abstechhalter**  
cut-off holder  
*höhenverstellbar / height adjustable*  
8 320 23 013 **SH 32 (1)** IK 70 bar  
8 320 23 018 **SH 32 (2)** IK 70 bar

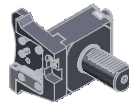

**Abstechhalter**  
cut-off holder **plh HORN plh**  
*höhenverstellbar / height adjustable*  
8 320 29 002 **HORN System 845 (1)** IK 70 bar  
8 320 29 015 **HORN System 845 (2)** IK 70 bar

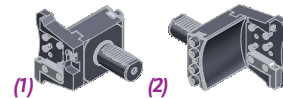

► Weitere Ausführungen auf Anfrage  
further versions on request

► Zubehör ZB...\*  
accessories ZB...\* 

► easy-quick 

► u-tec 

- ▶ *easy-quick HT Schnellwechselsystem*  
*easy-quick HT fast change system*

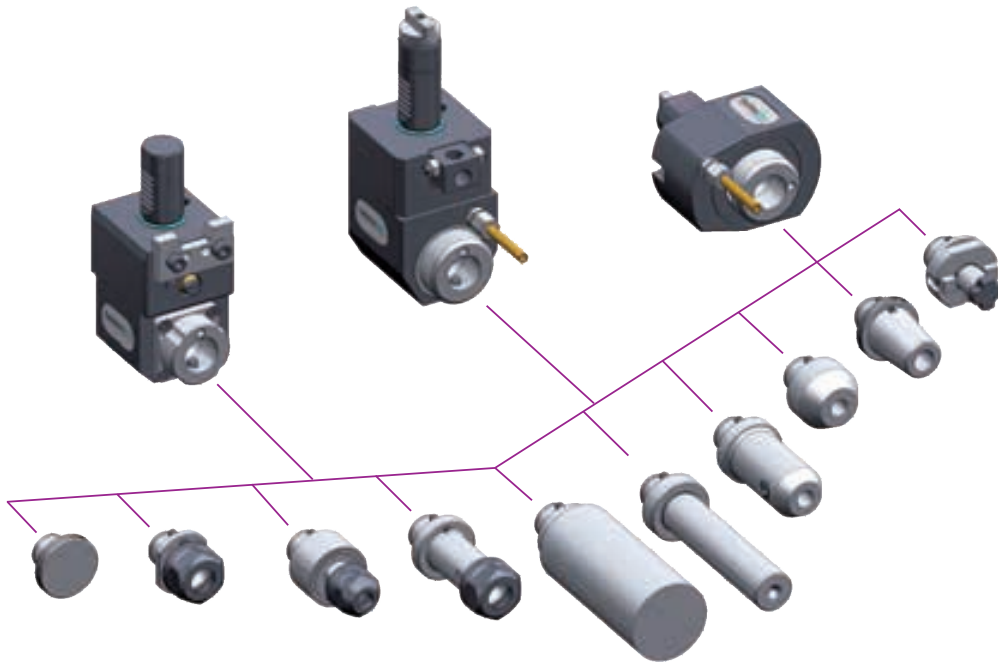

DAS Schnellwechselsystem von heimatec  
für angetriebene und feste Werkzeuge

*THE fast change system of heimatec  
for driven and static tools*

- ▶ Ausführungen siehe Katalog  
versions see catalogue

[www.heimatec.de](http://www.heimatec.de)  
Produkte / easy-quick

[www.heimatec.com](http://www.heimatec.com)  
products / easy-quick



► **u-tec<sup>®</sup> UT Wechselsystem**  
**u-tec<sup>®</sup> UT change system**

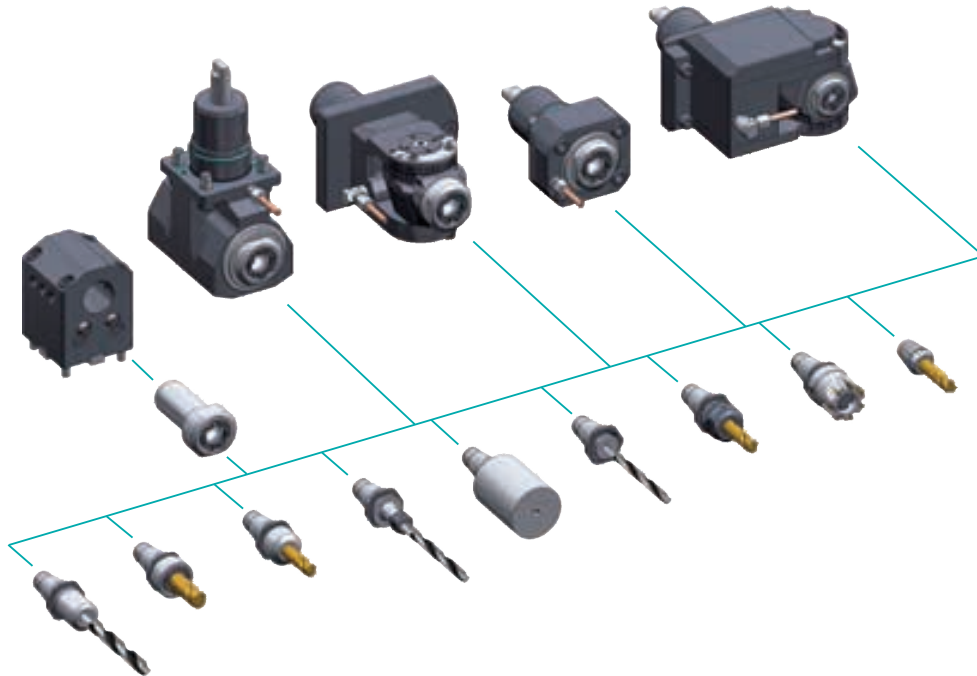

Unser Wechselsystem,  
das ALLES möglich macht

Our change system,  
that makes EVERYTHING possible

► Ausführungen siehe Katalog  
versions see catalogue



[www.heimatec.de](http://www.heimatec.de)  
Produkte / u-tec

[www.heimatec.com](http://www.heimatec.com)  
products / u-tec

► **Zubehör**  
accessories



► Ausführungen siehe Katalog  
versions see catalogue

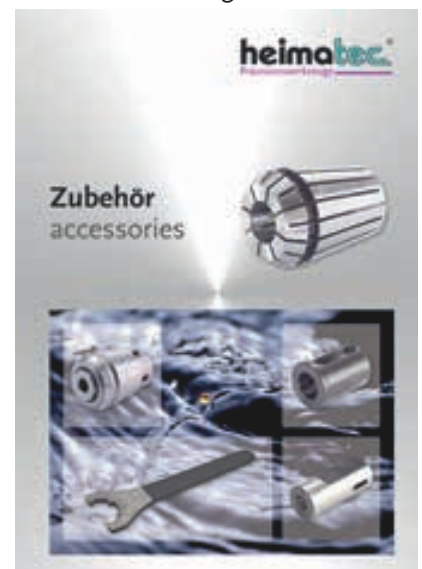

[www.heimatec.de](http://www.heimatec.de)  
Produkte / Zubehör

[www.heimatec.com](http://www.heimatec.com)  
products / accessories

# heimatec®

- heimatec®-Niederlassungen  
*heimatec® overseas branches*
- unsere weltweiten Vertretungen  
*global representations of heimatec®*



## Hauptsitz/headquarters

heimatec® GmbH  
Präzisionswerkzeuge  
Carl-Benz-Straße 4  
D- 77871 Renchen  
Postfach 11 36  
D- 77867 Renchen

Tel.: +49 (78 43) 94 66 0  
Fax: +49 (78 43) 94 66 66  
heimatec.de  
info@heimatec.de

heimatec® Inc.  
USA  
usa.heimatec.com  
USA@heimatec.com

heimatec®-Ost, JSC  
Russia  
ru.heimatec.com  
Russia@heimatec.com

heimatec® Ltd.  
Taiwan  
tw.heimatec.com  
Taiwan@heimatec.com

heimatec®  
Singapore  
sg.heimatec.com  
Singapore@heimatec.com

heimatec® India Pvt Ltd.  
India  
in.heimatec.com  
India@heimatec.com





# Werkzeugkatalog

tool catalogue

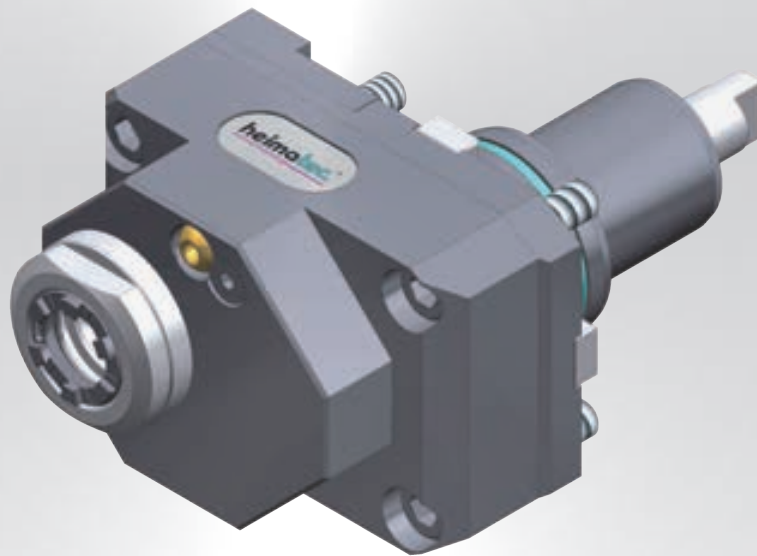

# Hwacheon

BMT 55

CUTEX 160 MC



Hinweis zu den AGBs:

Diese finden Sie in unserem Internetauftritt unter

**[www.heimatec.de](http://www.heimatec.de)**

Home/Impressum/AGB

Terms and conditions:

You will find them on our website

**[www.heimatec.com](http://www.heimatec.com)**

Home/Imprint/Terms and Conditions

Das Katalog-Werk einschließlich aller seiner Teile ist urheberrechtlich geschützt. Jede Verwertung außerhalb der engen Grenzen des Urheberrechtsgesetzes ist ohne Zustimmung der Rechteinhaber unzulässig und strafbar. Das gilt insbesondere für Vervielfältigungen, Übersetzungen, Mikroverfilmungen und die Einspeicherung und Verarbeitung in elektronischen Systemen.

**heimatec® GmbH** behält sich Änderungen technischer Art jederzeit ohne Vorankündigung vor. Dies gilt insbesondere bei Anpassungen an neue oder geänderte internationale Normen oder bei Weiterentwicklungen unserer Produkte oder Herstellungsprozesse.

This catalogue, including all its parts, is protected by copyright. Each use outside the restricted limitations of the Copyright Act is inadmissible and liable to prosecution without the consent of heimatec. This is particularly valid for duplication, translation, microfilming and feeding and processing in electronic systems.

**heimatec® GmbH** reserves the right of technical changes everytime without advance notice, which is particularly valid for adaptations to new or changed international standards, or to developments of our products or manufacturing processes.

angetriebene Werkzeuge  
driven tools



**Axial-Bohr- und Fräskopf**  
**axial drilling and milling head**

$n_{max} = 6000 \text{ min}^{-1}$

8 010 55 039	<b>ER 25 AX u-tec</b>	EK	1:1
8 010 55 038	<b>ER 25 AX u-tec</b>	IK 25 bar	1:1
8 010 55 057	<b>ER 25 AX u-tec</b>	IK 70 bar	1:1
8 010 56 039	<b>ER 32 AX u-tec</b>	EK	1:1
8 010 56 040	<b>ER 32 AX u-tec</b>	IK 25 bar	1:1
8 010 56 089	<b>ER 32 AX u-tec</b>	IK 70 bar	1:1
8 010 56 034	<b>easy quick HT 4</b>	EK	1:1
8 010 56 035	<b>easy quick HT 4</b>	IK 25 bar	1:1
8 010 56 087	<b>easy quick HT 4</b>	IK 70 bar	1:1



**Axial-Bohr- und Fräskopf**  
**axial drilling and milling head**

$n_{max} = 6000 \text{ min}^{-1}$

8 011 55 012	<b>Kombidorn/universal arbor 22</b>	EK 1:1	
--------------	-------------------------------------	--------	--

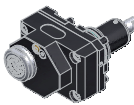

**Winkel-Bohr- und Fräskopf**  
**radial drilling and milling head**

Achsversatz / offset A=42

8 019 55 050	<b>ER 25 AX u-tec</b>	EK	1:1
8 019 55 054	<b>ER 25 AX u-tec</b>	IK 70 bar	1:1
$n_{max} = 6000 \text{ min}^{-1}$			
8 019 55 053	<b>ER 25 AX u-tec</b>	EK	1:2
8 019 55 057	<b>ER 25 AX u-tec</b>	IK 70 bar	1:2
$n_{max} = 12000 \text{ min}^{-1}$			
8 019 55 052	<b>ER 25 AX u-tec</b>	EK	1:3
8 019 55 056	<b>ER 25 AX u-tec</b>	IK 70 bar	1:3
$n_{max} = 18000 \text{ min}^{-1}$			
8 019 55 051	<b>ER 25 AX u-tec</b>	EK	2:1
8 019 55 055	<b>ER 25 AX u-tec</b>	IK 70 bar	2:1
$n_{max} = 3000 \text{ min}^{-1}$			

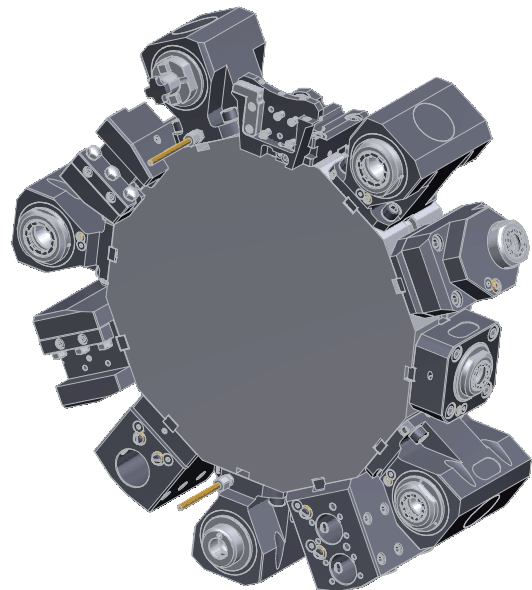

► Weitere Ausführungen auf Anfrage  
further versions on request

► Zubehör **ZB...\***  
accessories **ZB...\***

► **easy-quick**

► **u-tec**

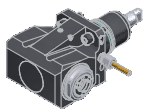

### Winkel-Bohr- und Fräskopf radial drilling and milling head

Mittenmaß / center distance  $H=70$   
 $n_{max} = 6000 \text{ min}^{-1}$

8 030 55 102	ER 25 AX u-tec	EK	1:1
8 030 55 120	ER 25 AX u-tec	IK 140 bar	1:1
8 030 56 052	ER 32 AX u-tec	EK	1:1
8 030 56 056	ER 32 AX u-tec	IK 140 bar	1:1
8 030 56 116	easy quick HT 4	EK	1:1
8 030 56 135	easy quick HT 4	IK 140 bar	1:1



### Winkel-Bohr- und Fräskopf radial drilling and milling head

Mittenmaß / center distance  $H=80$

8 030 55 068	ER 25 AX u-tec	EK	1:2
8 030 55 066	ER 25 AX u-tec	IK 140 bar	1:2
$n_{max} = 12000 \text{ min}^{-1}$			
8 030 55 069	ER 25 AX u-tec	EK	1:3
8 030 55 067	ER 25 AX u-tec	IK 140 bar	1:3
$n_{max} = 18000 \text{ min}^{-1}$			

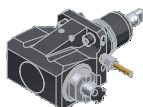

### Winkel-Bohr- und Fräskopf radial drilling and milling head

Mittenmaß / center distance  $H=70$   
 $n_{max} = 6000 \text{ min}^{-1}$

8 031 55 011	Kombidorn/universal arbor 22	EK	1:1
--------------	------------------------------	----	-----

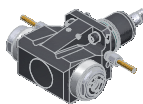

### Winkel-Bohr- und Fräskopf radial drilling and milling head

Mittenmaß / center distance  $H=70$   
 $n_{max} = 6000 \text{ min}^{-1}$   
doppelspindlig / double spindle

8 039 55 036	ER 25 AX u-tec	EK	1:1
8 039 56 022	ER 32 AX u-tec	EK	1:1

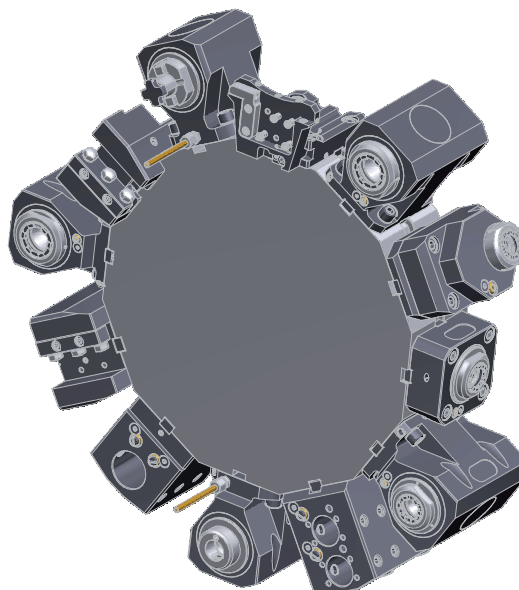

► Weitere Ausführungen auf Anfrage  
further versions on request

► Zubehör ZB...\*  
accessories ZB...\*



► easy-quick



► u-tec



**feste Werkzeuge**  
**static tool holders**

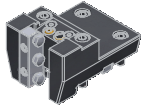

**Kombi-Drehstahlhalter**  
**universal turning holder**  
8 224 05 003 **Vierkant/square 25** EK

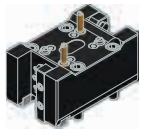

**Kombi-Doppel-Drehstahlhalter**  
**combi double turning holder**  
8 251 05 001 **Vierkant/square 25** EK

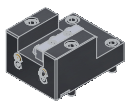

**Kombi-Plandrehhalter**  
**combi facing holder**  
8 244 05 003 **Vierkant/square 25** EK

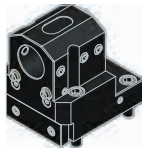

**Bohrstangenhalter**  
**boring bar holder**  
Mittenmaß / center distance  $H=70$   
8 240 08 002 **ø32** IK/EK  
8 240 09 009 **ø40** IK/EK



**Doppel-Bohrstangenhalter**  
**double boring bar holder**  
Mittenmaß / center distance  $H=52 / 97$   
8 253 07 011 **ø25** IK/EK  
8 253 08 002 **ø32** IK/EK

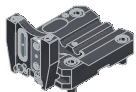

**Abstechhalter**  
**cut-off holder**  
*höhenverstellbar / height adjustable*  
8 320 02 014 **SH 26 (1)** IK 70 bar  
8 320 02 015 **SH 26 (2)** IK 70 bar  
8 320 03 008 **SH 32 (1)** IK 70 bar  
8 320 03 025 **SH 32 (2)** IK 70 bar

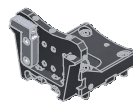
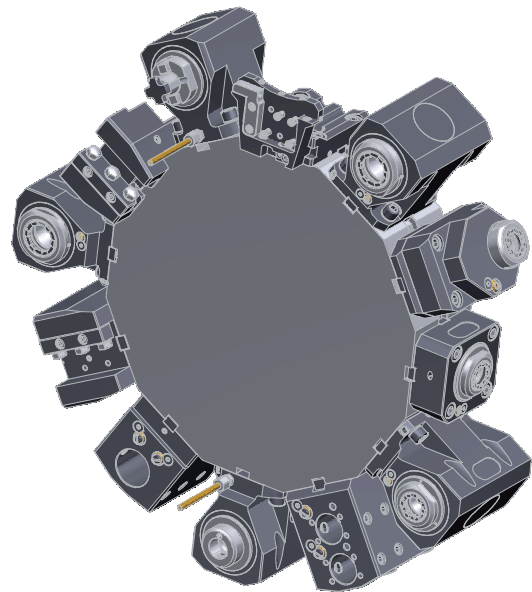
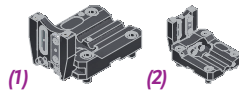

**Abstechhalter**  
**cut-off holder**   
*höhenverstellbar / height adjustable*

8 320 09 001 **HORN System 845 (1)** IK 70 bar  
8 320 09 014 **HORN System 845 (2)** IK 70 bar

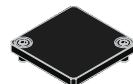
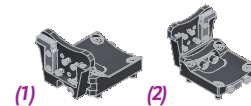

**Abdeckplatte**  
**cover plate**  
8 200 52 001

► Weitere Ausführungen auf Anfrage  
further versions on request

► Zubehör **ZB...\***  
accessories **ZB...\*** 

► **easy-quick** 

► **u-tec** 

► **easy-quick HT Schnellwechselsystem**  
*easy-quick HT fast change system*

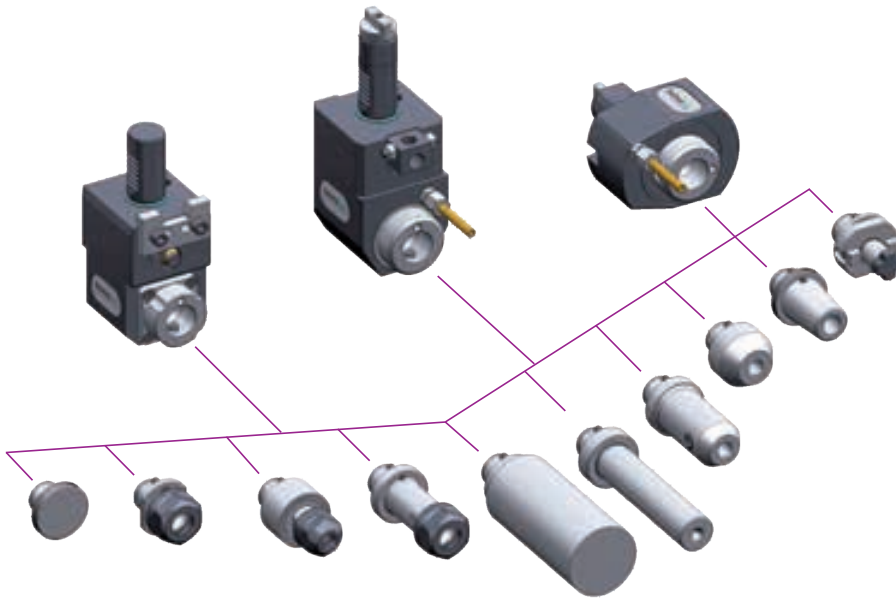

DAS Schnellwechselsystem von heimatec  
für angetriebene und feste Werkzeuge

*THE fast change system of heimatec  
for driven and static tools*

[www.heimatec.de](http://www.heimatec.de)  
Produkte / easy-quick

[www.heimatec.com](http://www.heimatec.com)  
products / easy-quick

► Ausführungen siehe Katalog  
versions see catalogue



► **u-tec<sup>®</sup> UT Wechselsystem**  
**u-tec<sup>®</sup> UT change system**

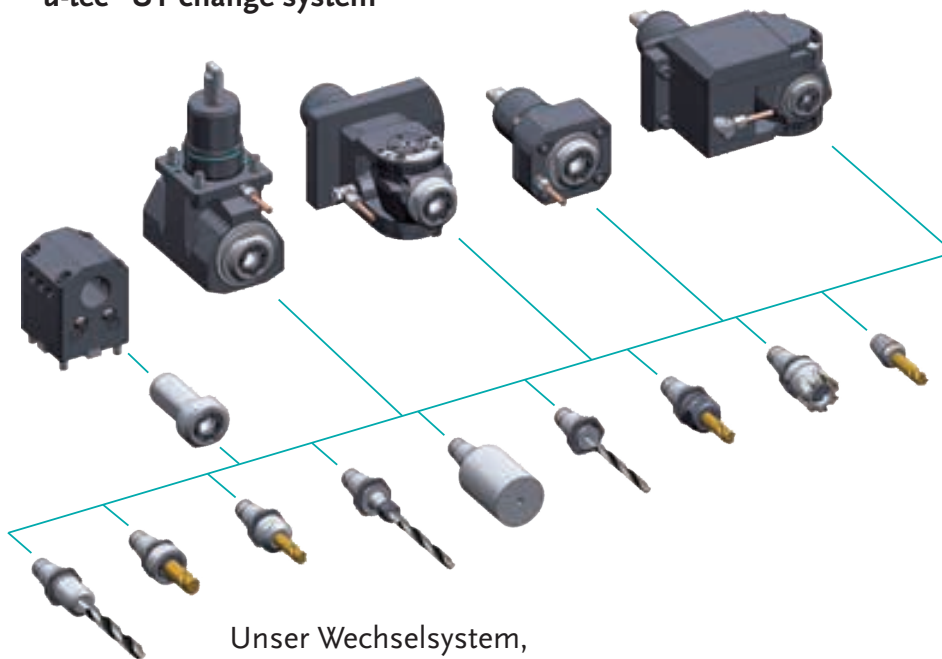

Unser Wechselsystem,  
das ALLES möglich macht

Our change system,  
that makes EVERYTHING possible

[www.heimatec.de](http://www.heimatec.de)  
Produkte / u-tec

[www.heimatec.com](http://www.heimatec.com)  
products / u-tec

► Ausführungen siehe Katalog  
versions see catalogue





# heimatec®

- heimatec®-Niederlassungen  
*heimatec® overseas branches*
- unsere weltweiten Vertretungen  
*global representations of heimatec®*



## Hauptsitz/headquarters

heimatec® GmbH  
Präzisionswerkzeuge  
Carl-Benz-Straße 4  
D- 77871 Renchen  
Postfach 11 36  
D- 77867 Renchen

Tel.: +49 (78 43) 94 66 0  
Fax: +49 (78 43) 94 66 66  
heimatec.de  
info@heimatec.de

heimatec® Inc.  
USA  
usa.heimatec.com  
USA@heimatec.com

heimatec®-Ost, JSC  
Russia  
ru.heimatec.com  
Russia@heimatec.com

heimatec® Ltd.  
Taiwan  
tw.heimatec.com  
Taiwan@heimatec.com

heimatec®  
Singapore  
sg.heimatec.com  
Singapore@heimatec.com

heimatec® India Pvt Ltd.  
India  
in.heimatec.com  
India@heimatec.com





# Werkzeugkatalog

tool catalogue

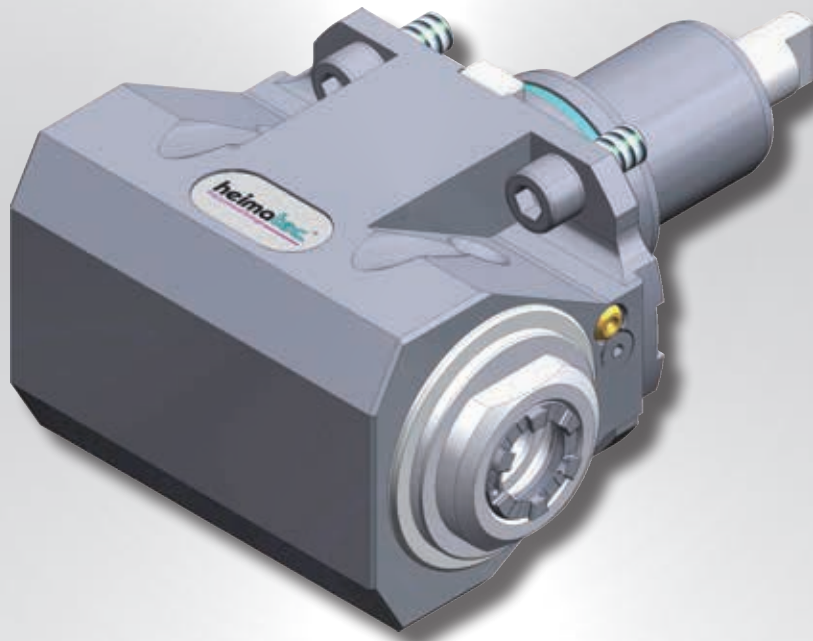

# Hwacheon

BMT 55

CUTEX 180 MC



Hinweis zu den AGBs:

Diese finden Sie in unserem Internetauftritt unter

**[www.heimatec.de](http://www.heimatec.de)**

Home/Impressum/AGB

Terms and conditions:

You will find them on our website

**[www.heimatec.com](http://www.heimatec.com)**

Home/Imprint/Terms and Conditions

Das Katalog-Werk einschließlich aller seiner Teile ist urheberrechtlich geschützt. Jede Verwertung außerhalb der engen Grenzen des Urheberrechtsgesetzes ist ohne Zustimmung der Rechteinhaber unzulässig und strafbar. Das gilt insbesondere für Vervielfältigungen, Übersetzungen, Mikroverfilmungen und die Einspeicherung und Verarbeitung in elektronischen Systemen.

**heimatec® GmbH** behält sich Änderungen technischer Art jederzeit ohne Vorankündigung vor. Dies gilt insbesondere bei Anpassungen an neue oder geänderte internationale Normen oder bei Weiterentwicklungen unserer Produkte oder Herstellungsprozesse.

This catalogue, including all its parts, is protected by copyright. Each use outside the restricted limitations of the Copyright Act is inadmissible and liable to prosecution without the consent of heimatec. This is particularly valid for duplication, translation, microfilming and feeding and processing in electronic systems.

**heimatec® GmbH** reserves the right of technical changes everytime without advance notice, which is particularly valid for adaptations to new or changed international standards, or to developments of our products or manufacturing processes.

angetriebene Werkzeuge  
driven tools



**Axial-Bohr- und Fräskopf**  
axial drilling and milling head

$n_{max} = 6000 \text{ min}^{-1}$

8 010 55 039	ER 25 AX u-tec	EK	1:1
8 010 55 038	ER 25 AX u-tec	IK 25 bar	1:1
8 010 55 057	ER 25 AX u-tec	IK 70 bar	1:1
8 010 56 039	ER 32 AX u-tec	EK	1:1
8 010 56 040	ER 32 AX u-tec	IK 25 bar	1:1
8 010 56 089	ER 32 AX u-tec	IK 70 bar	1:1
8 010 56 034	easy quick HT 4	EK	1:1
8 010 56 035	easy quick HT 4	IK 25 bar	1:1
8 010 56 087	easy quick HT 4	IK 70 bar	1:1



**Axial-Fräskopf**  
axial milling head

$n_{max} = 6000 \text{ min}^{-1}$

8 011 55 012	Kombidorn/universal arbor 22	EK 1:1
--------------	------------------------------	--------



**Winkel-Bohr- und Fräskopf**  
radial drilling and milling head

Achsversatz / offset A=42

8 019 55 050	ER 25 AX u-tec	EK	1:1
8 019 55 054	ER 25 AX u-tec	IK 70 bar	1:1
$n_{max} = 6000 \text{ min}^{-1}$			
8 019 55 053	ER 25 AX u-tec	EK	1:2
8 019 55 057	ER 25 AX u-tec	IK 70 bar	1:2
$n_{max} = 12000 \text{ min}^{-1}$			
8 019 55 052	ER 25 AX u-tec	EK	1:3
8 019 55 056	ER 25 AX u-tec	IK 70 bar	1:3
$n_{max} = 18000 \text{ min}^{-1}$			
8 019 55 051	ER 25 AX u-tec	EK	2:1
8 019 55 055	ER 25 AX u-tec	IK 70 bar	2:1
$n_{max} = 3000 \text{ min}^{-1}$			

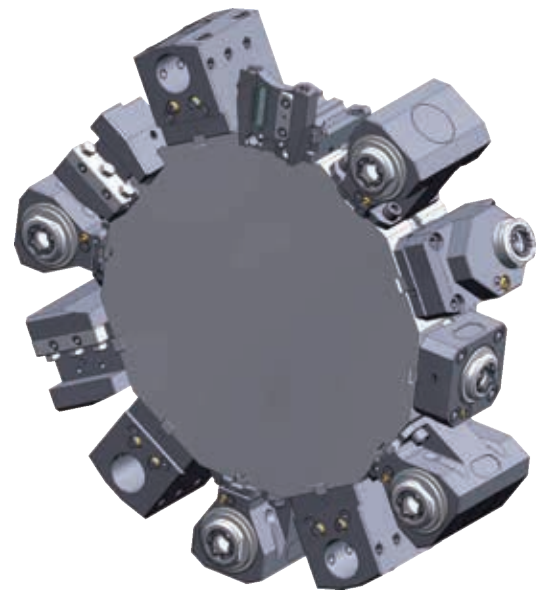

**Winkel-Bohr- und Fräskopf**  
radial drilling and milling head

Mittenmaß / center distance H=60

$n_{max} = 6000 \text{ min}^{-1}$

8 030 55 175	ER 25 AX u-tec	EK	1:1
8 030 55 176	ER 25 AX u-tec	IK 140 bar	1:1
8 030 56 168	easy quick HT 4	EK	1:1
8 030 56 169	easy quick HT 4	IK 140 bar	1:1



**Winkel-Fräskopf**  
radial milling head

Mittenmaß / center distance H=60

$n_{max} = 6000 \text{ min}^{-1}$

8 031 55 030	Kombidorn/universal arbor 22	EK 1:1
8 031 55 029	Kombidorn/universal arbor 1"	EK 1:1

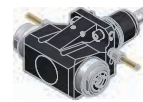

**Winkel-Bohr- und Fräskopf**  
radial drilling and milling head

Mittenmaß / center distance H=60

$n_{max} = 6000 \text{ min}^{-1}$

doppelspindlig / double spindle

8 039 55 051	2x ER 25 AX u-tec	EK	1:1
8 039 56 033	2x easy quick HT 4	EK	1:1

► Weitere Ausführungen auf Anfrage  
further versions on request

► Zubehör ZB...\*  
accessories ZB...\*

► easy-quick



► u-tec



**feste Werkzeuge**  
**static tool holders**

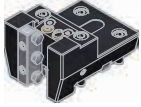

**Kombi-Drehstahlhalter**  
**universal turning holder**  
8 224 05 003 **Vierkant/square 25** EK

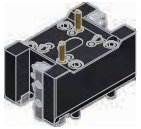

**Kombi-Doppel-Drehstahlhalter**  
**combi double turning holder**  
8 251 05 001 **Vierkant/square 25** EK



**Kombi-Plandrehhalter**  
**combi facing holder**  
8 244 05 003 **Vierkant/square 25** EK

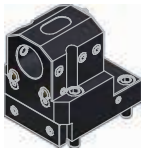

**Bohrstangenhalter**  
**boring bar holder**  
*Mittenmaß / center distance H=70*  
8 240 08 002 **ø32** IK/EK  
8 240 09 009 **ø40** IK/EK

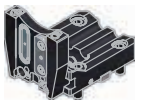

**Abstechhalter**  
**cut-off holder**  
*höhenverstellbar / height adjustable*  
8 320 02 014 **SH 26 (1)** IK 70 bar  
8 320 02 015 **SH 26 (2)** IK 70 bar  
8 320 03 008 **SH 32 (1)** IK 70 bar  
8 320 03 025 **SH 32 (2)** IK 70 bar

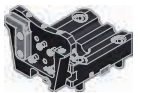
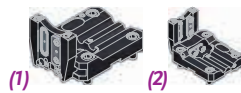

**Abstechhalter**  
**cut-off holder**  
*höhenverstellbar / height adjustable*  
8 320 09 001 **HORN System 845 (1)** IK 70 bar  
8 320 09 014 **HORN System 845 (2)** IK 70 bar

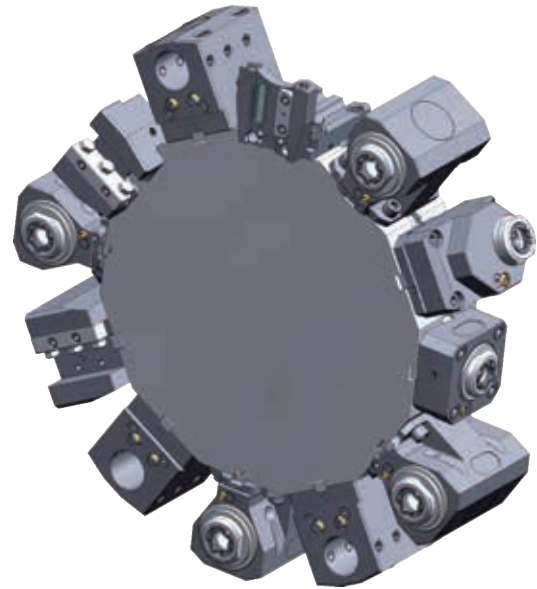
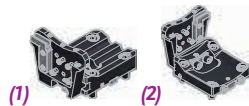

**Abdeckplatte**  
**cover plate**  
8 200 52 001



▶ Weitere Ausführungen auf Anfrage  
further versions on request

▶ Zubehör ZB...\*  
accessories ZB...\*



▶ **easy-quick**



▶ **u-tec**



- ▶ *easy-quick HT Schnellwechselsystem*  
*easy-quick HT fast change system*

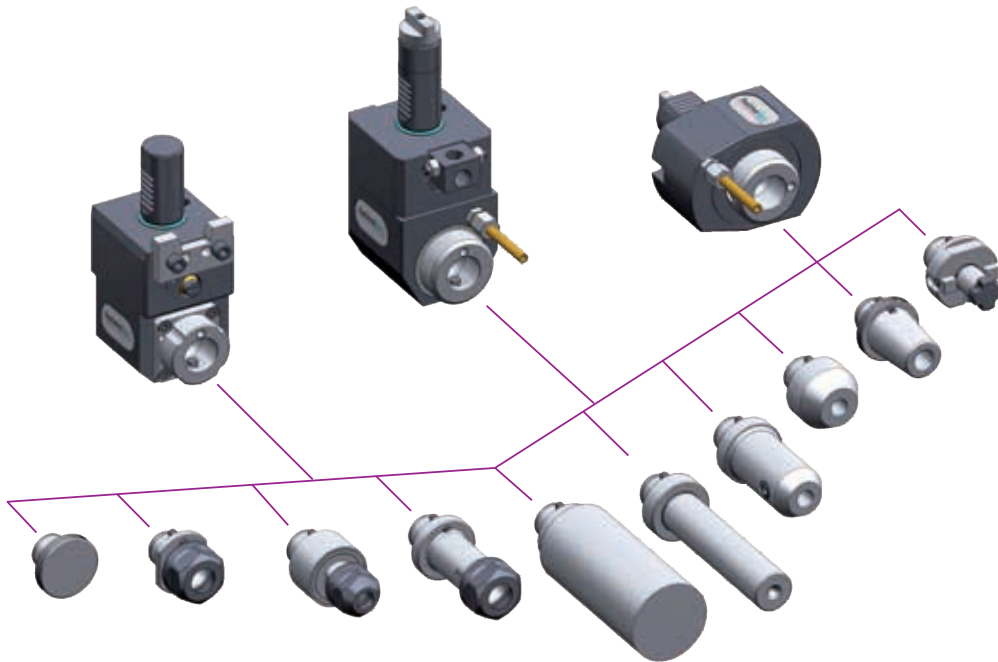

DAS Schnellwechselsystem von heimatec  
für angetriebene und feste Werkzeuge

*THE fast change system of heimatec  
for driven and static tools*

- ▶ Ausführungen siehe Katalog  
versions see catalogue

[www.heimatec.de](http://www.heimatec.de)  
Produkte / easy-quick

[www.heimatec.com](http://www.heimatec.com)  
products / easy-quick



► **u-tec**<sup>®</sup> UT Wechselsystem  
**u-tec**<sup>®</sup> UT change system

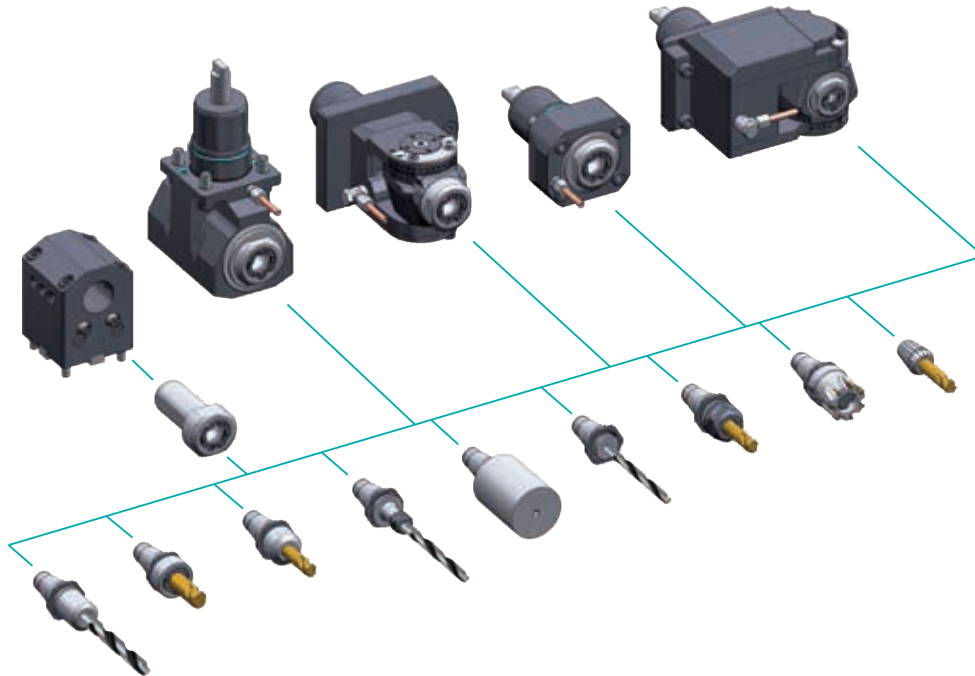

► Ausführungen siehe Katalog  
versions see catalogue

Unser Wechselsystem,  
das ALLES möglich macht

Our change system,  
that makes EVERYTHING possible

[www.heimatec.de](http://www.heimatec.de)  
Produkte / u-tec

[www.heimatec.com](http://www.heimatec.com)  
products / u-tec



► **Zubehör**  
accessories



► Ausführungen siehe Katalog  
versions see catalogue

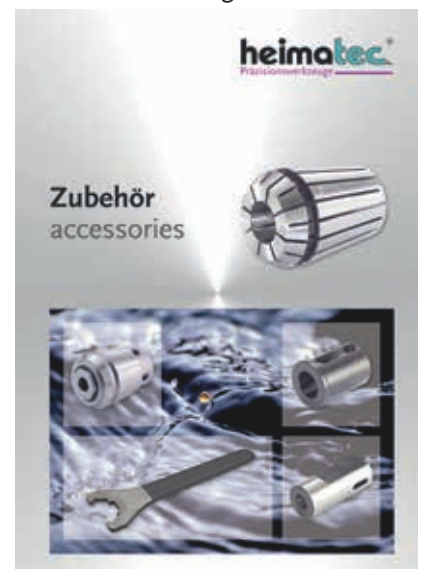

[www.heimatec.de](http://www.heimatec.de)  
Produkte / Zubehör

[www.heimatec.com](http://www.heimatec.com)  
products / accessories

# heimatec®

- heimatec®-Niederlassungen  
*heimatec® overseas branches*
- unsere weltweiten Vertretungen  
*global representations of heimatec®*



## Hauptsitz/headquarters

heimatec® GmbH  
Präzisionswerkzeuge  
Carl-Benz-Straße 4  
D- 77871 Renchen  
Postfach 11 36  
D- 77867 Renchen

Tel.: +49 (78 43) 94 66 0  
Fax: +49 (78 43) 94 66 66  
heimatec.de  
info@heimatec.de

heimatec® Inc.  
USA  
usa.heimatec.com  
USA@heimatec.com

heimatec®-Ost, JSC  
Russia  
ru.heimatec.com  
Russia@heimatec.com

heimatec® Ltd.  
Taiwan  
tw.heimatec.com  
Taiwan@heimatec.com

heimatec®  
Singapore  
sg.heimatec.com  
Singapore@heimatec.com

heimatec® India Pvt Ltd.  
India  
in.heimatec.com  
India@heimatec.com





# Werkzeugkatalog

tool catalogue

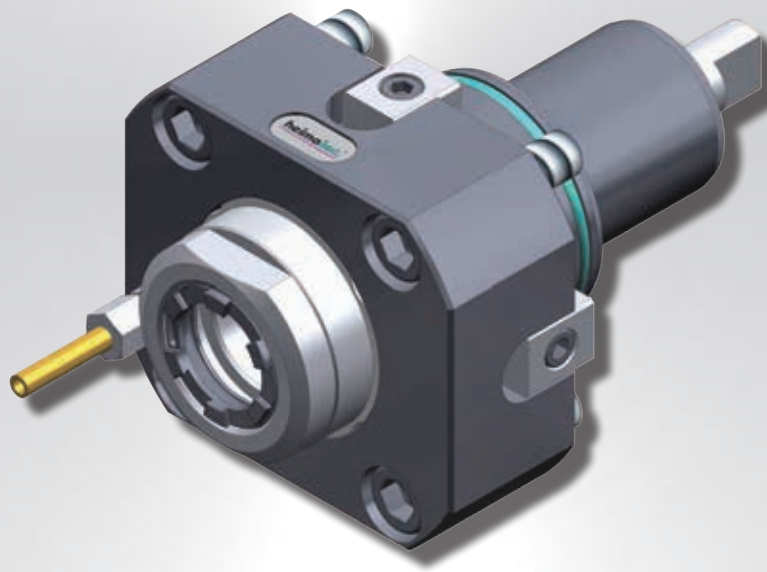

# Hwacheon

BMT 65

CUTEX 240 MC



Hinweis zu den AGBs:

Diese finden Sie in unserem Internetauftritt unter

**[www.heimatec.de](http://www.heimatec.de)**

Home/Impressum/AGB

Terms and conditions:

You will find them on our website

**[www.heimatec.com](http://www.heimatec.com)**

Home/Imprint/Terms and Conditions

Das Katalog-Werk einschließlich aller seiner Teile ist urheberrechtlich geschützt. Jede Verwertung außerhalb der engen Grenzen des Urheberrechtsgesetzes ist ohne Zustimmung der Rechteinhaber unzulässig und strafbar. Das gilt insbesondere für Vervielfältigungen, Übersetzungen, Mikroverfilmungen und die Einspeicherung und Verarbeitung in elektronischen Systemen.

**heimatec® GmbH** behält sich Änderungen technischer Art jederzeit ohne Vorankündigung vor. Dies gilt insbesondere bei Anpassungen an neue oder geänderte internationale Normen oder bei Weiterentwicklungen unserer Produkte oder Herstellungsprozesse.

This catalogue, including all its parts, is protected by copyright. Each use outside the restricted limitations of the Copyright Act is inadmissible and liable to prosecution without the consent of heimatec. This is particularly valid for duplication, translation, microfilming and feeding and processing in electronic systems.

**heimatec® GmbH** reserves the right of technical changes everytime without advance notice, which is particularly valid for adaptations to new or changed international standards, or to developments of our products or manufacturing processes.

angetriebene Werkzeuge  
driven tools



**Axial-Bohr- und Fräskopf**  
axial drilling and milling head

$n_{max} = 6000 \text{ min}^{-1}$

8 010 66 079	ER 32 AX u-tec	EK	1:1
8 010 66 081	ER 32 AX u-tec	IK 25 bar	1:1
8 010 66 046	ER 32 AX u-tec	IK 70 bar	1:1
8 010 67 025	easy quick HT 5	EK	1:1
8 010 67 026	easy quick HT 5	IK 25 bar	1:1
8 010 67 060	easy quick HT 5	IK 70 bar	1:1



**Axial-Bohr- und Fräskopf**  
axial drilling and milling head

$n_{max} = 24000 \text{ min}^{-1}$

8 013 64 008	ER 16 AX u-tec	EK	1:4
8 013 64 009	ER 16 AX u-tec	IK 70 bar	1:4



**Axial-Bohr- und Fräskopf**  
axial drilling and milling head

$n_{max} = 6000 \text{ min}^{-1}$

8 011 65 014	Kombidorn/universal arbor 22	EK 1:1	
8 011 65 011	Kombidorn/universal arbor 1"	EK 1:1	

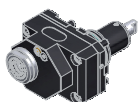

**Winkel-Bohr- und Fräskopf**  
radial drilling and milling head

Achsversatz / offset  $A=50$

8 019 65 021	ER 25 AX u-tec	EK	1:1
8 019 65 019	ER 25 AX u-tec	IK 70 bar	1:1
$n_{max} = 6000 \text{ min}^{-1}$			
8 019 65 004	ER 25 AX u-tec	EK	1:2
8 019 65 027	ER 25 AX u-tec	IK 70 bar	1:2
$n_{max} = 12000 \text{ min}^{-1}$			
8 019 65 025	ER 25 AX u-tec	EK	1:3
8 019 65 026	ER 25 AX u-tec	IK 70 bar	1:3
$n_{max} = 15000 \text{ min}^{-1}$			
8 019 65 023	ER 25 AX u-tec	EK	2:1
8 019 65 024	ER 25 AX u-tec	IK 70 bar	2:1
$n_{max} = 3000 \text{ min}^{-1}$			

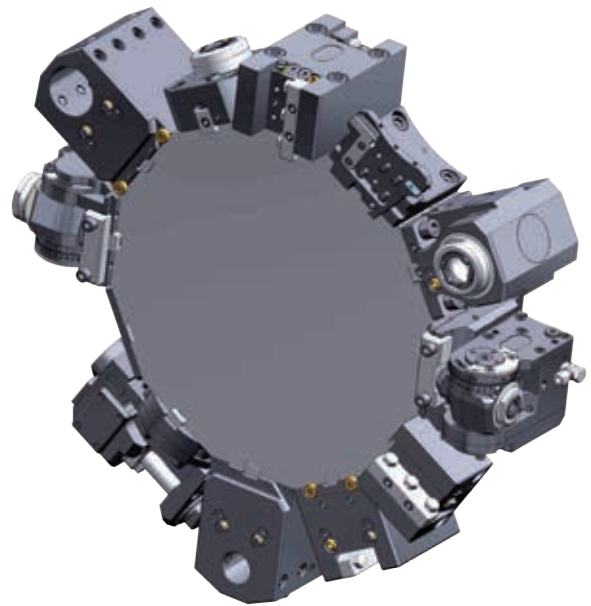

**Winkel-Bohr- und Fräskopf**  
radial drilling and milling head

Mittenmaß / center distance  $H=72$   
 $n_{max} = 6000 \text{ min}^{-1}$

8 030 66 097	ER 32 AX u-tec	EK	1:1
8 030 66 098	ER 32 AX u-tec	IK 140 bar	1:1
8 030 67 025	easy quick HT 5	EK	1:1
8 030 67 075	easy quick HT 5	IK 140 bar	1:1



**Winkel-Bohr- und Fräskopf**  
radial drilling and milling head

Mittenmaß / center distance  $H=72$   
 $n_{max} = 24000 \text{ min}^{-1}$

8 030 64 021	ER 16 AX u-tec	EK	1:4
8 030 64 023	ER 16 AX u-tec	IK 140 bar	1:4



**Winkel-Bohr- und Fräskopf**  
radial drilling and milling head

Mittenmaß / center distance  $H=95$

8 030 65 055	ER 25 AX u-tec	EK	1:2
8 030 65 063	ER 25 AX u-tec	IK 140 bar	1:2
$n_{max} = 12000 \text{ min}^{-1}$			
8 030 65 064	ER 25 AX u-tec	EK	1:3
8 030 65 065	ER 25 AX u-tec	IK 140 bar	1:3
$n_{max} = 18000 \text{ min}^{-1}$			

► Weitere Ausführungen auf Anfrage  
further versions on request

► Zubehör ZB...\*  
accessories ZB...\*

► easy-quick

► u-tec

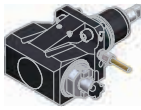

### Winkel-Bohr- und Fräskopf radial drilling and milling head

Mittenmaß / center distance  $H=70$   
 $n_{max} = 6000 \text{ min}^{-1}$

8 031 65 015	Kombidorn/universal arbor 22	EK	1:1
8 031 65 010	Kombidorn/universal arbor 1"	EK	1:1



### Winkel-Bohr- und Fräskopf radial drilling and milling head

Mittenmaß / center distance  $H=72$   
 $n_{max} = 6000 \text{ min}^{-1}$   
doppelspindlig / double spindle

8 039 66 025	ER 32 AX u-tec	EK	1:1
8 039 67 009	easy quick HT 5	IK 140 bar	1:1



### Schwenkkopf universal head

Mittenmaß / center distance  $H=69$   
Achsversatz / offset  $A=60$

8 043 65 000	ER 25 AX u-tec	EK	1:1
8 043 65 004	ER 25 AX u-tec	IK 140 bar	1:1
$n_{max} = 6000 \text{ min}^{-1}$			
8 043 64 008	ER 16 AX u-tec	EK	1:2
8 043 64 009	ER 16 AX u-tec	IK 140 bar	1:2
$n_{max} = 12000 \text{ min}^{-1}$			

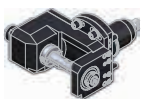

### Winkel-Scheibenfräserkopf radial disk mill head

$\pm 10^\circ$  drehbar  
 $\pm 10^\circ$  turnable

Mittenmaß / center distance  $H=87,5$   
auf  $0^\circ$  absteckbar /  $0^\circ$  can be pinned  
kein Kühlmittel / no coolant  
 $n_{max} = 3000 \text{ min}^{-1}$

8 037 64 023	$\varnothing 16$	2:1
8 037 65 008	$\varnothing 22$	2:1
8 037 64 003	$\varnothing 3/4"$	2:1
8 037 65 019	$\varnothing 1"$	2:1

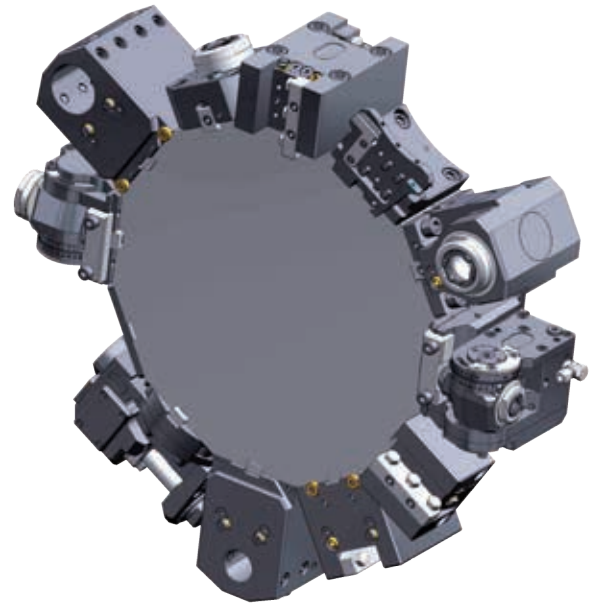

**feste Werkzeuge**  
**static tool holders**

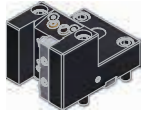

**Kombi-Drehstahlhalter**  
**universal turning holder**

8 224 15 006 **Vierkant/square 25** EK  
8 224 15 016 **Vierkant/square 1"** EK

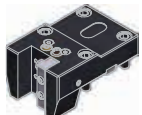

**Kombi-Drehstahlhalter**  
**universal turning holder**

8 224 15 005 **Vierkant/square 25** EK  
8 224 15 015 **Vierkant/square 1"** EK



**Kombi-Doppel-Drehstahlhalter**  
**combi double turning holder**

8 251 15 003 **Vierkant/square 25** EK  
8 251 15 008 **Vierkant/square 1"** EK

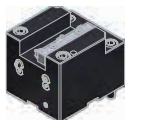

**Kombi-Plandrehhalter**  
**combi facing holder**

8 244 15 005 **Vierkant/square 25** EK  
8 244 15 006 **Vierkant/square 1"** EK



**Bohrstangenhalter**  
**boring bar holder**

*Mittenmaß / center distance H=72*

8 240 18 028 **ø32** IK/EK  
8 240 19 032 **ø40** IK/EK  
8 240 19 044 **ø1,5"** IK/EK  
8 240 19 048 **ø2"** IK/EK



**Spannzangenhalter**  
**collet chuck holder**

*Mittenmaß / center distance H=72*

8 240 16 021 **ER 32** IK/EK

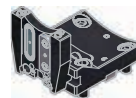
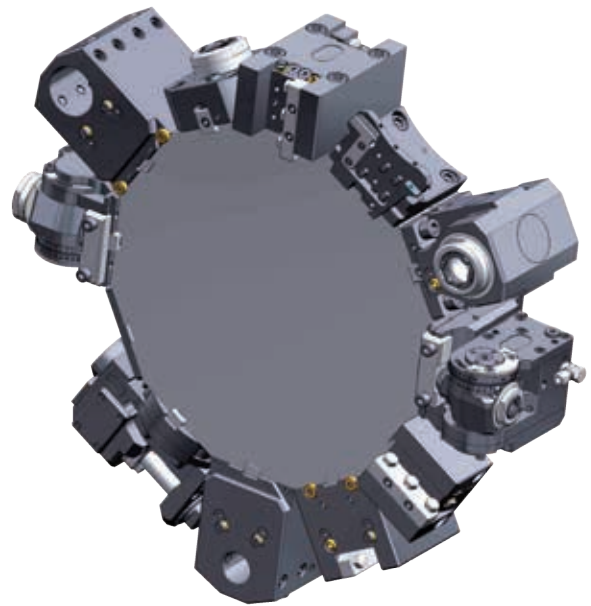

**Abstechhalter**  
**cut-off holder**



*höhenverstellbar / height adjustable*

8 320 12 017 **SH 26 (1)** IK 70 bar  
8 320 12 018 **SH 26 (2)** IK 70 bar  
8 320 13 005 **SH 32 (1)** IK 70 bar  
8 320 13 020 **SH 32 (2)** IK 70 bar



**Abstechhalter**  
**cut-off holder**



*höhenverstellbar / height adjustable*

8 320 19 000 **HORN System 845 (1)** IK 70 bar  
8 320 19 020 **HORN System 845 (2)** IK 70 bar

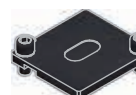
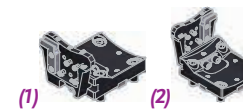

**Abdeckplatte**  
**cover plate**

8 200 03 005

► Weitere Ausführungen auf Anfrage  
further versions on request

► Zubehör **ZB...\***  
accessories **ZB...\***

► **easy-quick**

► **u-tec**

► **easy-quick HT Schnellwechselsystem**  
*easy-quick HT fast change system*

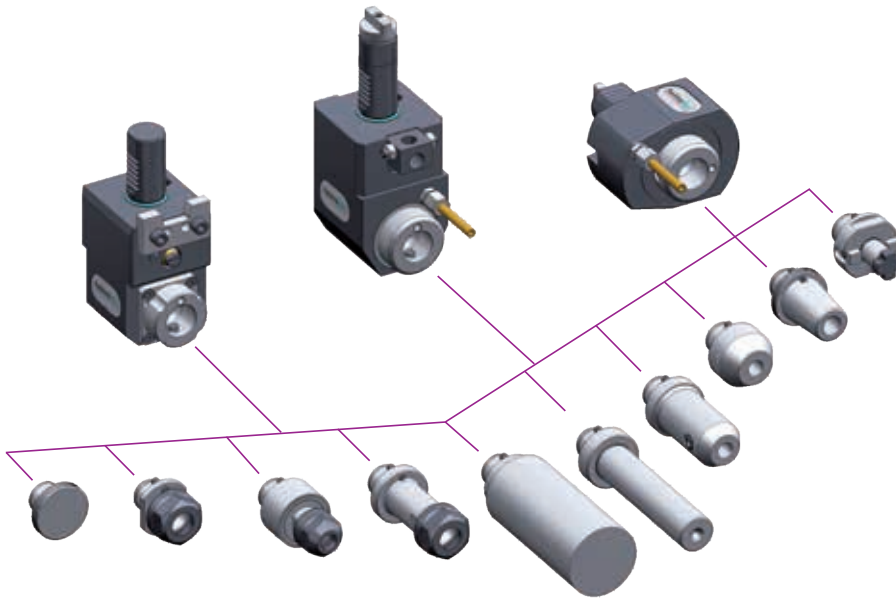

DAS Schnellwechselsystem von heimatec  
für angetriebene und feste Werkzeuge

*THE fast change system of heimatec  
for driven and static tools*

[www.heimatec.de](http://www.heimatec.de)  
Produkte / easy-quick

[www.heimatec.com](http://www.heimatec.com)  
products / easy-quick

► Ausführungen siehe Katalog  
versions see catalogue



► **u-tec<sup>®</sup> UT Wechselsystem**  
*u-tec<sup>®</sup> UT change system*

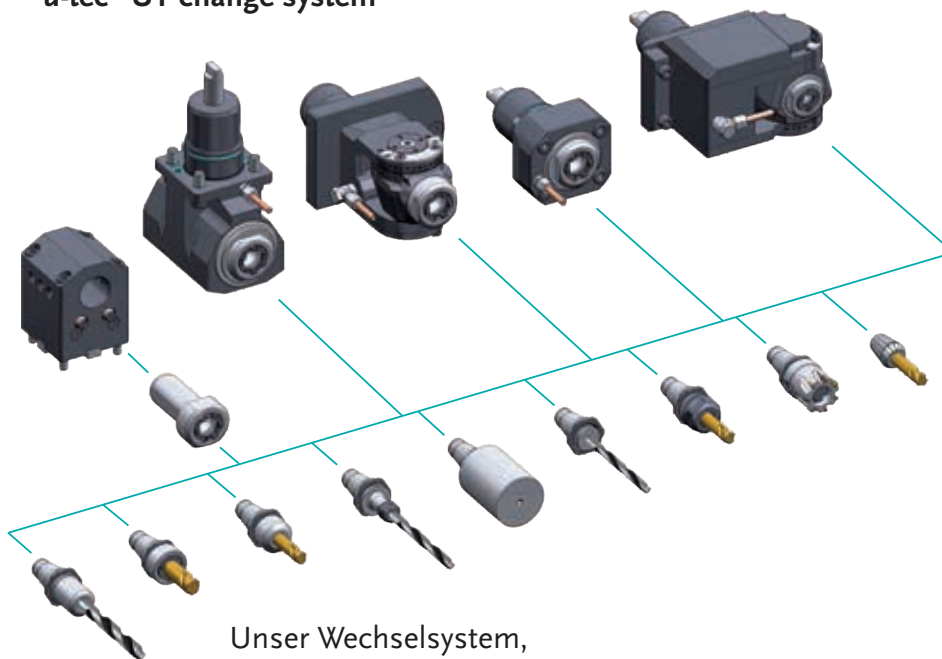

Unser Wechselsystem,  
das ALLES möglich macht

Our change system,  
that makes EVERYTHING possible

[www.heimatec.de](http://www.heimatec.de)  
Produkte / u-tec

[www.heimatec.com](http://www.heimatec.com)  
products / u-tec

► Ausführungen siehe Katalog  
versions see catalogue





# heimatec®

- heimatec®-Niederlassungen  
*heimatec® overseas branches*
- unsere weltweiten Vertretungen  
*global representations of heimatec®*



2017/06



## Hauptsitz/headquarters

heimatec® GmbH  
Präzisionswerkzeuge  
Carl-Benz-Straße 4  
D- 77871 Renchen  
Postfach 11 36  
D- 77867 Renchen  
Tel.: +49 (78 43) 94 66 0  
Fax: +49 (78 43) 94 66 66  
heimatec.de  
info@heimatec.de

heimatec® Inc.  
USA  
usa.heimatec.com  
USA@heimatec.com  
  
heimatec®-Ost, JSC  
Russia  
ru.heimatec.com  
Russia@heimatec.com

heimatec® Ltd.  
Taiwan  
tw.heimatec.com  
Taiwan@heimatec.com  
  
heimatec®  
Singapore  
sg.heimatec.com  
Singapore@heimatec.com

heimatec® India Pvt Ltd.  
India  
in.heimatec.com  
India@heimatec.com  
  
heimatec®  
China  
cn.heimatec.com  
China@heimatec.com



# Werkzeugkatalog

tool catalogue

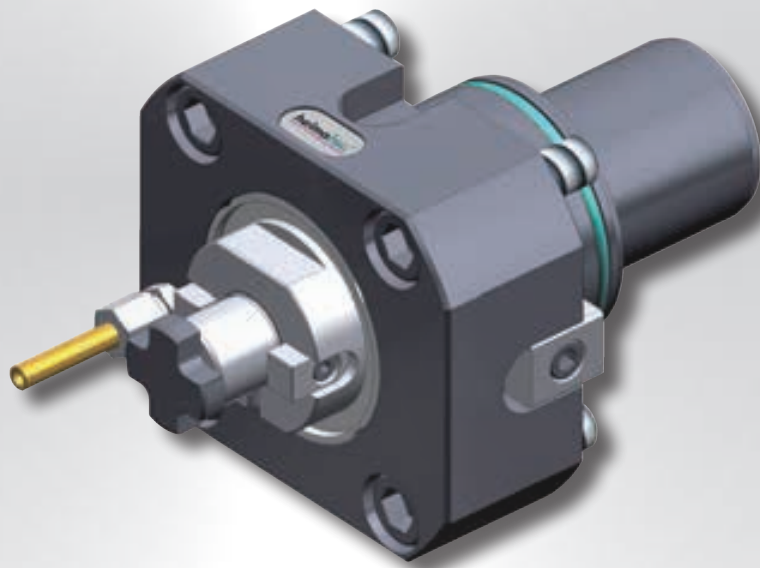

# Hwacheon

BMT 65

Hi-TECH 200 MC



Hinweis zu den AGBs:

Diese finden Sie in unserem Internetauftritt unter

**[www.heimatec.de](http://www.heimatec.de)**

Home/Impressum/AGB

Terms and conditions:

You will find them on our website

**[www.heimatec.com](http://www.heimatec.com)**

Home/Imprint/Terms and Conditions

Das Katalog-Werk einschließlich aller seiner Teile ist urheberrechtlich geschützt. Jede Verwertung außerhalb der engen Grenzen des Urheberrechtsgesetzes ist ohne Zustimmung der Rechteinhaber unzulässig und strafbar. Das gilt insbesondere für Vervielfältigungen, Übersetzungen, Mikroverfilmungen und die Einspeicherung und Verarbeitung in elektronischen Systemen.

**heimatec® GmbH** behält sich Änderungen technischer Art jederzeit ohne Vorankündigung vor. Dies gilt insbesondere bei Anpassungen an neue oder geänderte internationale Normen oder bei Weiterentwicklungen unserer Produkte oder Herstellungsprozesse.

This catalogue, including all its parts, is protected by copyright. Each use outside the restricted limitations of the Copyright Act is inadmissible and liable to prosecution without the consent of heimatec. This is particularly valid for duplication, translation, microfilming and feeding and processing in electronic systems.

**heimatec® GmbH** reserves the right of technical changes everytime without advance notice, which is particularly valid for adaptations to new or changed international standards, or to developments of our products or manufacturing processes.

## angetriebene Werkzeuge

driven tools



**Axial-Bohr- und Fräskopf**  
axial drilling and milling head

$n_{max} = 6000 \text{ min}^{-1}$

8 010 66 079	<b>ER 32 AX u-tec</b>	EK	1:1
8 010 66 081	<b>ER 32 AX u-tec</b>	IK 25 bar	1:1
8 010 66 046	<b>ER 32 AX u-tec</b>	IK 70 bar	1:1
8 010 67 025	<b>easy-quick HT 5</b>	EK	1:1
8 010 67 026	<b>easy-quick HT 5</b>	IK 25 bar	1:1
8 010 67 060	<b>easy-quick HT 5</b>	IK 70 bar	1:1

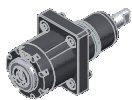

**Axial-Bohr- und Fräskopf**  
axial drilling and milling head

$n_{max} = 24000 \text{ min}^{-1}$

8 013 64 008	<b>ER 16 AX u-tec</b>	EK	1:4
8 013 64 009	<b>ER 16 AX u-tec</b>	IK 70 bar	1:4



**Axial-Fräskopf**  
axial milling head

$n_{max} = 6000 \text{ min}^{-1}$

8 011 65 014	Kombidom/universal arbor 22	EK	1:1
8 011 65 011	Kombidom/universal arbor 14	EK	1:1



**Axial-Bohr- und Fräskopf**  
axial drilling and milling head

Achsversatz / offset  $A=50$

8 019 65 021	<b>ER 25 AX u-tec</b>	EK	1:1
8 019 65 019	<b>ER 25 AX u-tec</b>	IK 140 bar	1:1
$n_{max} = 6000 \text{ min}^{-1}$			
8 019 65 004	<b>ER 25 AX u-tec</b>	EK	1:2
8 019 65 027	<b>ER 25 AX u-tec</b>	IK 140 bar	1:2
$n_{max} = 12000 \text{ min}^{-1}$			
8 019 65 023	<b>ER 25 AX u-tec</b>	EK	2:1
8 019 65 024	<b>ER 25 AX u-tec</b>	IK 140 bar	2:1
$n_{max} = 3000 \text{ min}^{-1}$			
8 019 65 025	<b>ER 25 AX u-tec</b>	EK	1:3
8 019 65 026	<b>ER 25 AX u-tec</b>	IK 140 bar	1:3
$n_{max} = 15000 \text{ min}^{-1}$			

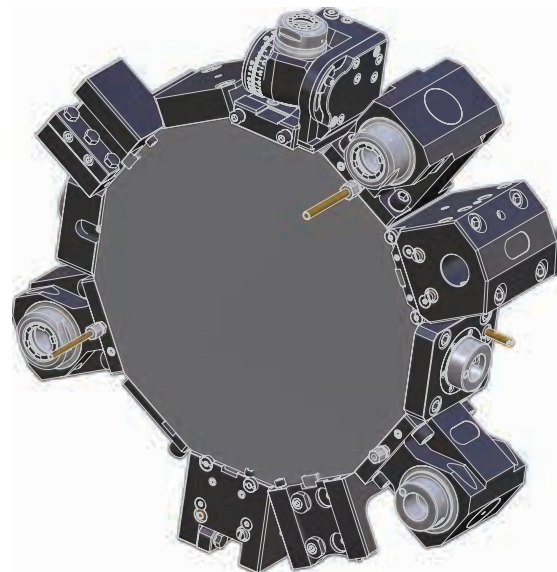

**Winkel-Bohr- und Fräskopf**  
radial drilling and milling head

Mittenmaß / center distance  $H=72$   
 $n_{max} = 6000 \text{ min}^{-1}$

8 030 66 097	<b>ER 32 AX u-tec</b>	EK	1:1
8 030 66 098	<b>ER 32 AX u-tec</b>	IK 140 bar	1:1
8 030 67 025	<b>easy-quick HT 5</b>	EK	1:1
8 030 67 075	<b>easy-quick HT 5</b>	IK 140 bar	1:1

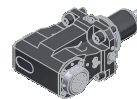

**Axial-Bohr- und Fräskopf**  
axial drilling and milling head

Mittenmaß / center distance  $H=95$

8 030 65 055	<b>ER 25 AX u-tec</b>	EK	1:2
8 030 65 063	<b>ER 25 AX u-tec</b>	IK 140 bar	1:2
$n_{max} = 12000 \text{ min}^{-1}$			
8 030 65 064	<b>ER 25 AX u-tec</b>	EK	1:3
8 030 65 065	<b>ER 25 AX u-tec</b>	IK 140 bar	1:3
$n_{max} = 18000 \text{ min}^{-1}$			

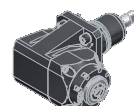

**Winkel-Bohr- und Fräskopf**  
radial drilling and milling head

Mittenmaß / center distance  $H=72$   
 $n_{max} = 24000 \text{ min}^{-1}$

8 030 64 021	<b>ER 16 AX u-tec</b>	EK	1:4
8 030 64 023	<b>ER 16 AX u-tec</b>	IK 140 bar	1:4

► Weitere Ausführungen auf Anfrage  
further versions on request

► Zubehör **ZB...\***  
accessories **ZB...\***

► **easy-quick**



► **u-tec**



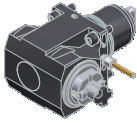

### Winkel-Fräskopf radial milling head

Mittenmaß / center distance  $H=72$   
 $n_{max} = 6000 \text{ min}^{-1}$

8 031 65 015	Kombidorn/universal arbor 22	EK	1:1
8 031 65 010	Kombidorn/universal arbor 1"	EK	1:1

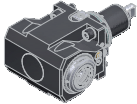

### Winkel-Bohr- und Fräskopf radial drilling and milling head

Mittenmaß / center distance  $H=72$   
doppelspindlig / double spindle  
 $n_{max} = 6000 \text{ min}^{-1}$

8 039 66 025	ER 32 AX u-tec	EK	1:1
8 039 67 009	easy-quick HT 5	EK	1:1



### Schwenkkopf universal head

Mittenmaß / center distance  $H=69$   
Achsversatz / offset  $A=60$

8 043 65 000	ER 25 AX u-tec	EK	1:1
8 043 65 004	ER 25 AX u-tec	IK 140 bar	1:1
$n_{max} = 6000 \text{ min}^{-1}$			
8 043 64 008	ER 16 AX u-tec	EK	1:2
8 043 64 009	ER 16 AX u-tec	IK 140 bar	1:2
$n_{max} = 12000 \text{ min}^{-1}$			

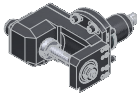

### Winkel-Scheibenfräserkopf radial disk mill head

$\pm 10^\circ$  drehbar  
 $\pm 10^\circ$  turnable

Mittenmaß / center distance  $H=87,5$   
auf  $0^\circ$  absteckbar /  $0^\circ$  can be pinned  
kein Kühlmittel / no coolant  
 $n_{max} = 3000 \text{ min}^{-1}$

8 037 64 023	$\varnothing 16$	2:1
8 037 65 008	$\varnothing 22$	2:1
8 037 64 003	$\varnothing 3/4"$	2:1
8 037 65 019	$\varnothing 1"$	2:1

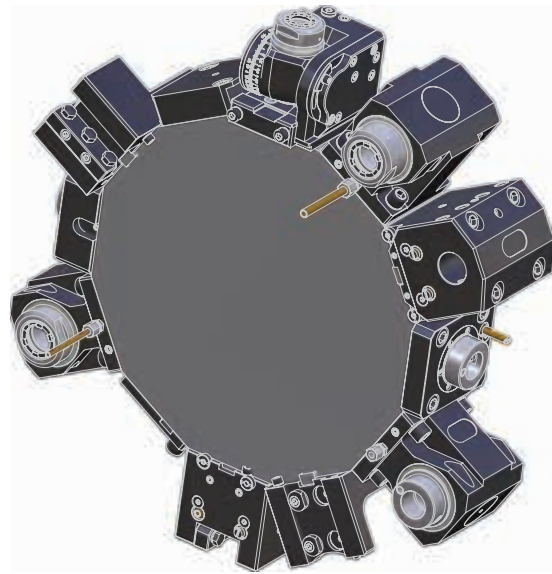

► Weitere Ausführungen auf Anfrage  
further versions on request

► Zubehör ZB...\*  
accessories ZB...\*



► easy-quick



► u-tec



## feste Werkzeuge static tool holders

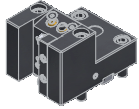

**Kombi-Drehstahlhalter**  
universal turning holder

8 224 15 006 **Vierkant/square 25** EK  
8 224 15 016 **Vierkant/square 1"** EK

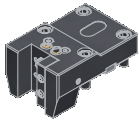

**Kombi-Drehstahlhalter**  
universal turning holder

8 224 15 005 **Vierkant/square 25** EK  
8 224 15 015 **Vierkant/square 1"** EK

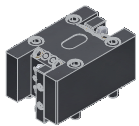

**Kombi-Doppel-Drehstahlhalter**  
combi double turning holder

8 251 15 003 **Vierkant/square 25** EK  
8 251 15 008 **Vierkant/square 1"** EK

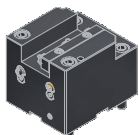

**Kombi-Plandrehhalter**  
combi facing holder

8 244 15 005 **Vierkant/square 25** EK  
8 244 15 006 **Vierkant/square 1"** EK



**Bohrstangenhalter**  
boring bar holder

Mittenmaß / center distance H=72

8 240 18 028 **ø32** IK/EK  
8 240 19 032 **ø40** IK/EK  
8 240 19 044 **ø1,5"** IK/EK  
8 240 19 048 **ø2"** IK/EK

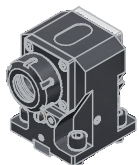

**Spannzangenhalter**  
collet chuck holder

Mittenmaß / center distance H=72

8 240 16 021 **ER 32** IK/EK

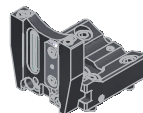
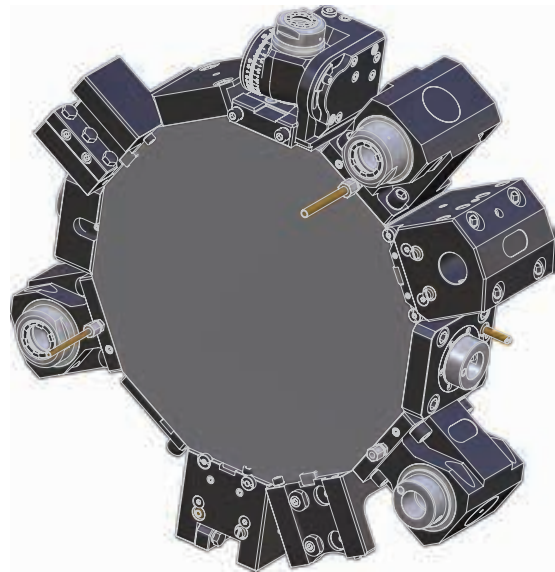

**Abstechhalter**  
cut-off holder

höhenverstellbar / height adjustable

8 320 13 005 **SH 32** IK 70 bar

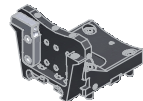

**Abstechhalter**  
cut-off holder

höhenverstellbar / height adjustable

8 320 19 000 **HORN System 845** IK 70 bar

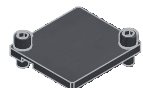

**Abdeckblech**  
cover plate

8 200 03 005

► Weitere Ausführungen auf Anfrage  
further versions on request

► Zubehör **ZB...\***  
accessories **ZB...\***

► **easy-quick**

► **u-tec**

► **easy-quick HT Schnellwechselsystem**  
*easy-quick HT fast change system*

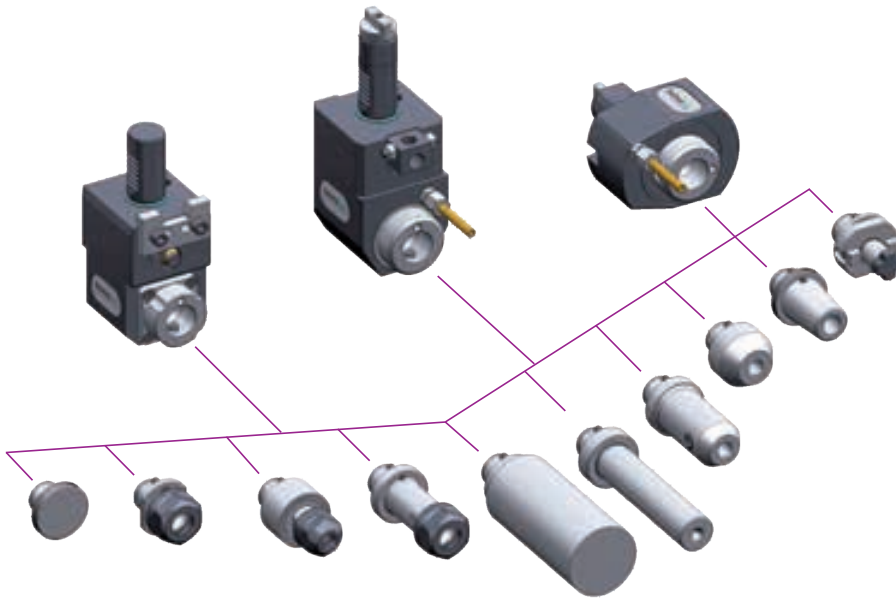

DAS Schnellwechselsystem von heimatec  
für angetriebene und feste Werkzeuge

*THE fast change system of heimatec  
for driven and static tools*

[www.heimatec.de](http://www.heimatec.de)  
Produkte / easy-quick

[www.heimatec.com](http://www.heimatec.com)  
products / easy-quick

► Ausführungen siehe Katalog  
versions see catalogue



► **u-tec<sup>®</sup> UT Wechselsystem**  
**u-tec<sup>®</sup> UT change system**

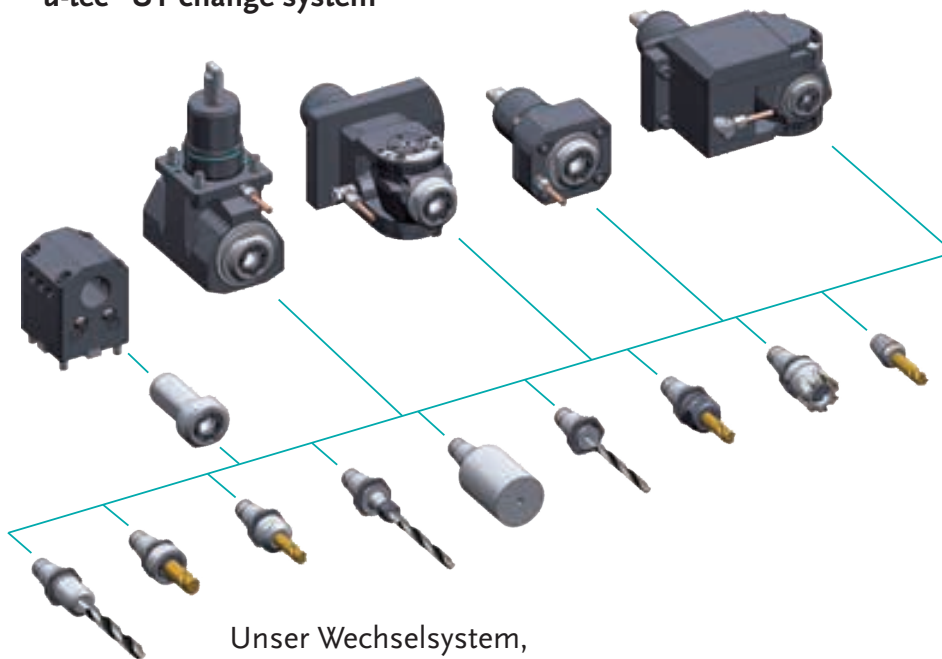

Unser Wechselsystem,  
das ALLES möglich macht

Our change system,  
that makes EVERYTHING possible

[www.heimatec.de](http://www.heimatec.de)  
Produkte / u-tec

[www.heimatec.com](http://www.heimatec.com)  
products / u-tec

► Ausführungen siehe Katalog  
versions see catalogue





# heimatec®

- heimatec®-Niederlassungen  
*heimatec® overseas branches*
- unsere weltweiten Vertretungen  
*global representations of heimatec®*



## Hauptsitz/headquarters

heimatec® GmbH  
Präzisionswerkzeuge  
Carl-Benz-Straße 4  
D- 77871 Renchen  
Postfach 11 36  
D- 77867 Renchen  
Tel.: +49 (78 43) 94 66 0  
Fax: +49 (78 43) 94 66 66  
heimatec.de  
info@heimatec.de

heimatec® Inc.  
USA  
usa.heimatec.com  
USA@heimatec.com  
  
heimatec®-Ost, JSC  
Russia  
ru.heimatec.com  
Russia@heimatec.com

heimatec® Ltd.  
Taiwan  
tw.heimatec.com  
Taiwan@heimatec.com  
  
heimatec®  
Singapore  
sg.heimatec.com  
Singapore@heimatec.com

heimatec® India Pvt Ltd.  
India  
in.heimatec.com  
India@heimatec.com





# Werkzeugkatalog

tool catalogue

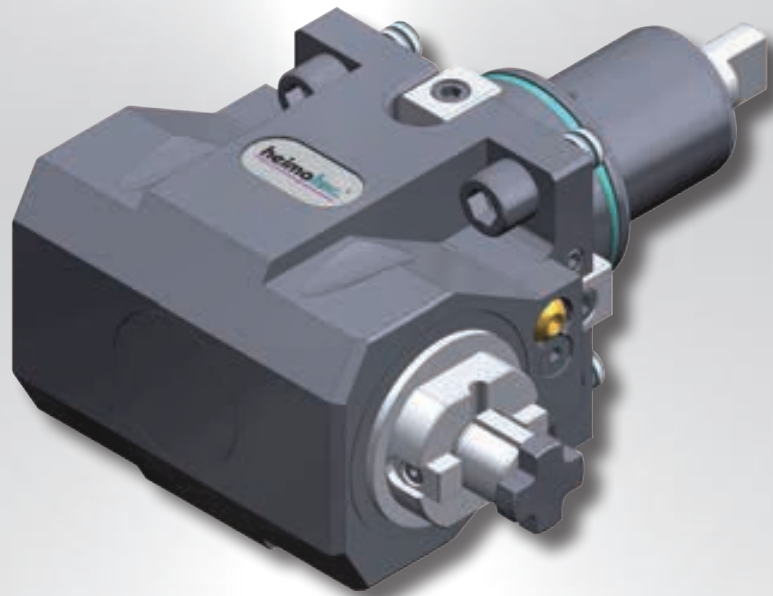

# Hwacheon

BMT 65

Hi-TECH 300 MC



Hinweis zu den AGBs:

Diese finden Sie in unserem Internetauftritt unter

**[www.heimatec.de](http://www.heimatec.de)**

Home/Impressum/AGB

Terms and conditions:

You will find them on our website

**[www.heimatec.com](http://www.heimatec.com)**

Home/Imprint/Terms and Conditions

Das Katalog-Werk einschließlich aller seiner Teile ist urheberrechtlich geschützt. Jede Verwertung außerhalb der engen Grenzen des Urheberrechtsgesetzes ist ohne Zustimmung der Rechteinhaber unzulässig und strafbar. Das gilt insbesondere für Vervielfältigungen, Übersetzungen, Mikroverfilmungen und die Einspeicherung und Verarbeitung in elektronischen Systemen.

**heimatec® GmbH** behält sich Änderungen technischer Art jederzeit ohne Vorankündigung vor. Dies gilt insbesondere bei Anpassungen an neue oder geänderte internationale Normen oder bei Weiterentwicklungen unserer Produkte oder Herstellungsprozesse.

This catalogue, including all its parts, is protected by copyright. Each use outside the restricted limitations of the Copyright Act is inadmissible and liable to prosecution without the consent of heimatec. This is particularly valid for duplication, translation, microfilming and feeding and processing in electronic systems.

**heimatec® GmbH** reserves the right of technical changes everytime without advance notice, which is particularly valid for adaptations to new or changed international standards, or to developments of our products or manufacturing processes.

angetriebene Werkzeuge  
driven tools

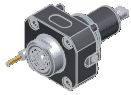

**Axial-Bohr- und Fräskopf**  
**axial drilling and milling head**

$n_{max} = 6000 \text{ min}^{-1}$

8 010 66 079	<b>ER 32 AX u-tec</b>	EK	1:1
8 010 66 081	<b>ER 32 AX u-tec</b>	IK 25 bar	1:1
8 010 66 046	<b>ER 32 AX u-tec</b>	IK 70 bar	1:1
8 010 67 025	<b>easy-quick HT 5</b>	EK	1:1
8 010 67 026	<b>easy-quick HT 5</b>	IK 25 bar	1:1
8 010 67 060	<b>easy-quick HT 5</b>	IK 70 bar	1:1

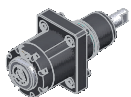

**Axial-Bohr- und Fräskopf**  
**axial drilling and milling head**

$n_{max} = 24000 \text{ min}^{-1}$

8 013 64 008	<b>ER 16 AX u-tec</b>	EK	1:4
8 013 64 009	<b>ER 16 AX u-tec</b>	IK 70 bar	1:4



**Axial-Fräskopf**  
**axial milling head**

$n_{max} = 6000 \text{ min}^{-1}$

8 011 65 014	Kombidom/universal arbor 22	EK	1:1
8 011 65 011	Kombidom/universal arbor 14	EK	1:1



**Axial-Bohr- und Fräskopf**  
**axial drilling and milling head**

Achsversatz / offset  $A=50$

8 019 65 021	<b>ER 25 AX u-tec</b>	EK	1:1
8 019 65 019	<b>ER 25 AX u-tec</b>	IK 140 bar	1:1
$n_{max} = 6000 \text{ min}^{-1}$			
8 019 65 004	<b>ER 25 AX u-tec</b>	EK	1:2
8 019 65 027	<b>ER 25 AX u-tec</b>	IK 140 bar	1:2
$n_{max} = 12000 \text{ min}^{-1}$			
8 019 65 023	<b>ER 25 AX u-tec</b>	EK	2:1
8 019 65 024	<b>ER 25 AX u-tec</b>	IK 140 bar	2:1
$n_{max} = 3000 \text{ min}^{-1}$			
8 019 65 025	<b>ER 25 AX u-tec</b>	EK	1:3
8 019 65 026	<b>ER 25 AX u-tec</b>	IK 140 bar	1:3
$n_{max} = 15000 \text{ min}^{-1}$			

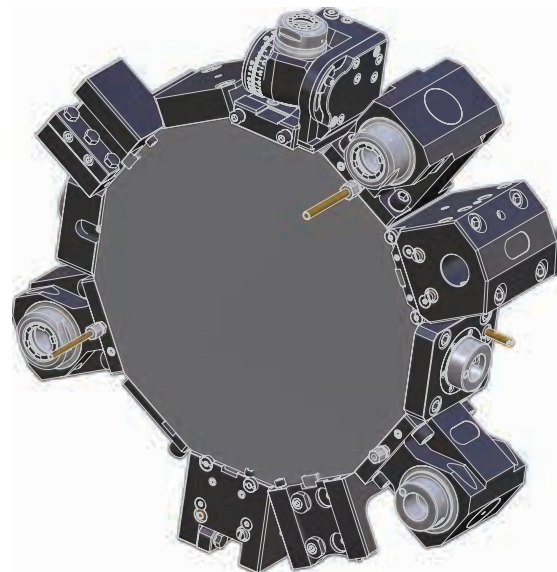

**Winkel-Bohr- und Fräskopf**  
**radial drilling and milling head**

Mittenmaß / center distance  $H=72$   
 $n_{max} = 6000 \text{ min}^{-1}$

8 030 66 097	<b>ER 32 AX u-tec</b>	EK	1:1
8 030 66 098	<b>ER 32 AX u-tec</b>	IK 140 bar	1:1
8 030 67 025	<b>easy-quick HT 5</b>	EK	1:1
8 030 67 075	<b>easy-quick HT 5</b>	IK 140 bar	1:1

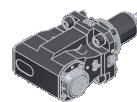

**Axial-Bohr- und Fräskopf**  
**axial drilling and milling head**

Mittenmaß / center distance  $H=95$

8 030 65 055	<b>ER 25 AX u-tec</b>	EK	1:2
8 030 65 063	<b>ER 25 AX u-tec</b>	IK 140 bar	1:2
$n_{max} = 12000 \text{ min}^{-1}$			
8 030 65 064	<b>ER 25 AX u-tec</b>	EK	1:3
8 030 65 065	<b>ER 25 AX u-tec</b>	IK 140 bar	1:3
$n_{max} = 18000 \text{ min}^{-1}$			

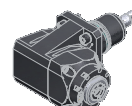

**Winkel-Bohr- und Fräskopf**  
**radial drilling and milling head**

Mittenmaß / center distance  $H=72$   
 $n_{max} = 24000 \text{ min}^{-1}$

8 030 64 021	<b>ER 16 AX u-tec</b>	EK	1:4
8 030 64 023	<b>ER 16 AX u-tec</b>	IK 140 bar	1:4

► Weitere Ausführungen auf Anfrage  
further versions on request

► Zubehör **ZB...\***  
accessories **ZB...\***

► **easy-quick**



► **u-tec**



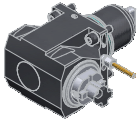

**Winkel-Fräskopf  
radial milling head**

Mittenmaß / center distance  $H=72$   
 $n_{max} = 6000 \text{ min}^{-1}$

8 031 65 015	Kombidorn/universal arbor 22	EK	1:1
8 031 65 010	Kombidorn/universal arbor 1"	EK	1:1

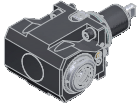

**Winkel-Bohr- und Fräskopf  
radial drilling and milling head**

Mittenmaß / center distance  $H=72$   
doppelspindlig / double spindle  
 $n_{max} = 6000 \text{ min}^{-1}$

8 039 66 025	ER 32 AX u-tec	EK	1:1
8 039 67 009	easy-quick HT 5	EK	1:1

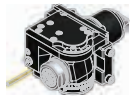

**Schwenkkopf  
universal head**

Mittenmaß / center distance  $H=69$   
Achsversatz / offset  $A=60$

8 043 65 000	ER 25 AX u-tec	EK	1:1
8 043 65 004	ER 25 AX u-tec	IK 140 bar	1:1
$n_{max} = 6000 \text{ min}^{-1}$			
8 043 64 008	ER 16 AX u-tec	EK	1:2
8 043 64 009	ER 16 AX u-tec	IK 140 bar	1:2
$n_{max} = 12000 \text{ min}^{-1}$			

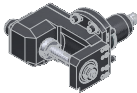

**Winkel-Scheibenfräserkopf  
radial disk mill head**

$\pm 10^\circ$  drehbar  
 $\pm 10^\circ$  turnable

Mittenmaß / center distance  $H=87,5$   
auf 0° absteckbar / 0° can be pinned  
kein Kühlmittel / no coolant  
 $n_{max} = 3000 \text{ min}^{-1}$

8 037 64 023	$\varnothing 16$	2:1
8 037 65 008	$\varnothing 22$	2:1
8 037 64 003	$\varnothing 3/4"$	2:1
8 037 65 019	$\varnothing 1"$	2:1

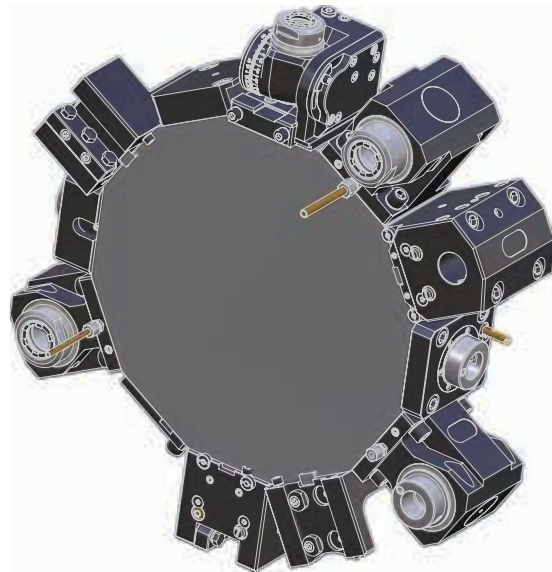

► Weitere Ausführungen auf Anfrage  
further versions on request

► Zubehör ZB...\*  
accessories ZB...\*



► easy-quick



► u-tec



## feste Werkzeuge static tool holders

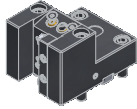

**Kombi-Drehstahlhalter**  
universal turning holder

8 224 15 006 **Vierkant/square 25** EK  
8 224 15 016 **Vierkant/square 1"** EK

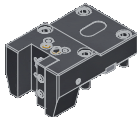

**Kombi-Drehstahlhalter**  
universal turning holder

8 224 15 005 **Vierkant/square 25** EK  
8 224 15 015 **Vierkant/square 1"** EK

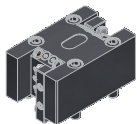

**Kombi-Doppel-Drehstahlhalter**  
combi double turning holder

8 251 15 003 **Vierkant/square 25** EK  
8 251 15 008 **Vierkant/square 1"** EK

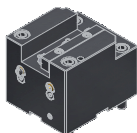

**Kombi-Plandrehhalter**  
combi facing holder

8 244 15 005 **Vierkant/square 25** EK  
8 244 15 006 **Vierkant/square 1"** EK



**Bohrstangenhalter**  
boring bar holder

Mittenmaß / center distance H=72

8 240 18 028 **ø32** IK/EK  
8 240 19 032 **ø40** IK/EK  
8 240 19 044 **ø1,5"** IK/EK  
8 240 19 048 **ø2"** IK/EK

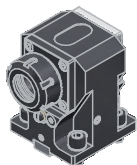

**Spannzangenhalter**  
collet chuck holder

Mittenmaß / center distance H=72

8 240 16 021 **ER 32** IK/EK

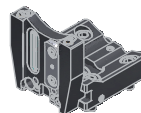
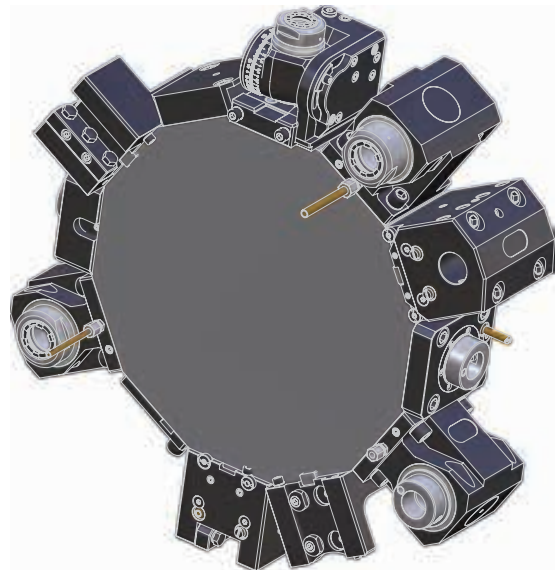

**Abstechhalter**  
cut-off holder

höhenverstellbar / height adjustable

8 320 13 005 **SH 32** IK 70 bar

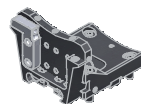

**Abstechhalter**  
cut-off holder

höhenverstellbar / height adjustable

8 320 19 000 **HORN System 845** IK 70 bar

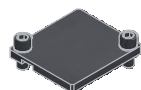

**Abdeckblech**  
cover plate

8 200 03 005

► Weitere Ausführungen auf Anfrage  
further versions on request

► Zubehör **ZB...**\*  
accessories **ZB...**\* 

► **easy-quick** 

► **u-tec** 

► **easy-quick HT Schnellwechselsystem**  
*easy-quick HT fast change system*

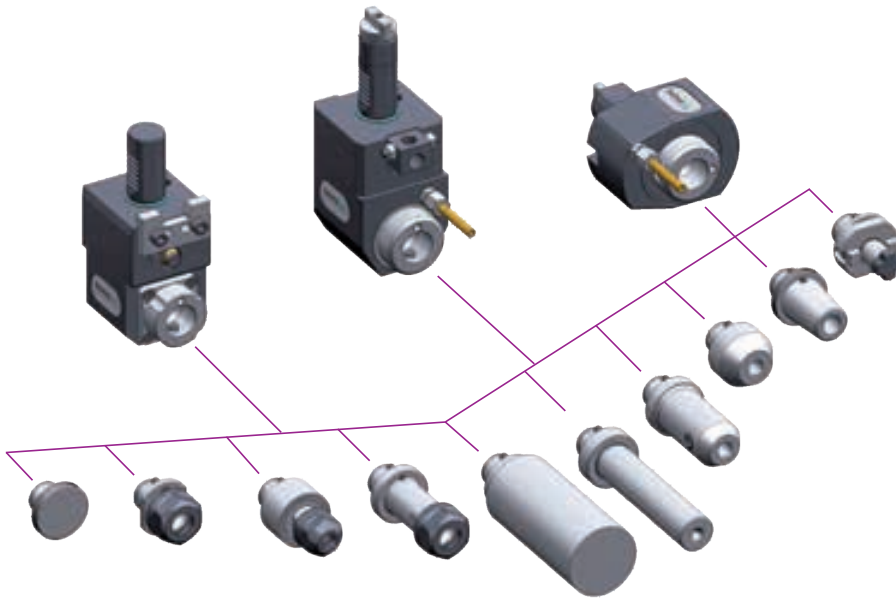

DAS Schnellwechselsystem von heimatec  
für angetriebene und feste Werkzeuge

*THE fast change system of heimatec  
for driven and static tools*

[www.heimatec.de](http://www.heimatec.de)  
Produkte / easy-quick

[www.heimatec.com](http://www.heimatec.com)  
products / easy-quick

► Ausführungen siehe Katalog  
versions see catalogue



► **u-tec<sup>®</sup> UT Wechselsystem**  
**u-tec<sup>®</sup> UT change system**

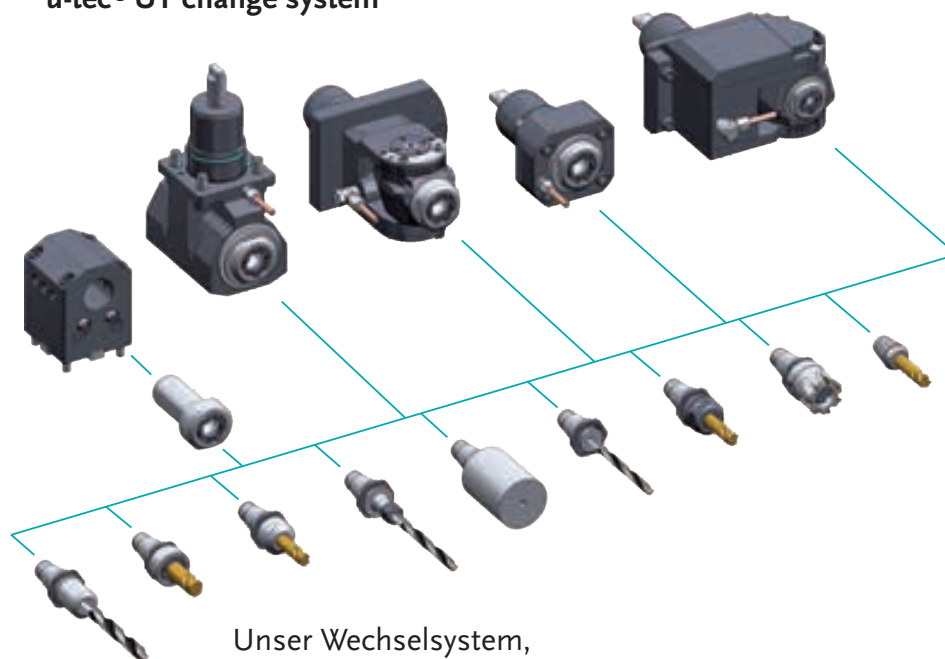

Unser Wechselsystem,  
das ALLES möglich macht

Our change system,  
that makes EVERYTHING possible

[www.heimatec.de](http://www.heimatec.de)  
Produkte / u-tec

[www.heimatec.com](http://www.heimatec.com)  
products / u-tec

► Ausführungen siehe Katalog  
versions see catalogue





# heimatec®

- heimatec®-Niederlassungen  
*heimatec® overseas branches*
- unsere weltweiten Vertretungen  
*global representations of heimatec®*



## Hauptsitz/headquarters

heimatec® GmbH  
Präzisionswerkzeuge  
Carl-Benz-Straße 4  
D- 77871 Renchen  
Postfach 11 36  
D- 77867 Renchen

Tel.: +49 (78 43) 94 66 0  
Fax: +49 (78 43) 94 66 66  
heimatec.de  
info@heimatec.de

heimatec® Inc.  
USA  
usa.heimatec.com  
USA@heimatec.com

heimatec®-Ost, JSC  
Russia  
ru.heimatec.com  
Russia@heimatec.com

heimatec® Ltd.  
Taiwan  
tw.heimatec.com  
Taiwan@heimatec.com

heimatec®  
Singapore  
sg.heimatec.com  
Singapore@heimatec.com

heimatec® India Pvt Ltd.  
India  
in.heimatec.com  
India@heimatec.com





# Werkzeugkatalog

tool catalogue

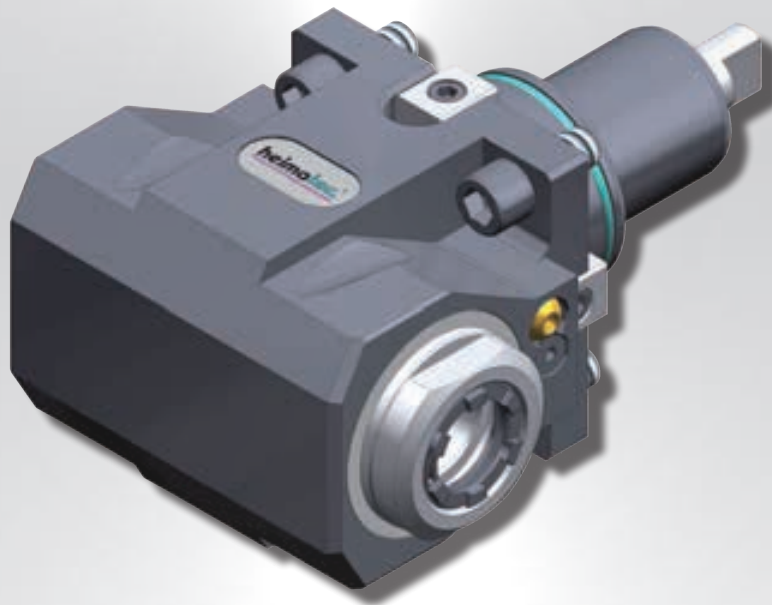

# Hwacheon

BMT 65

Hi-TECH 400 MC



Hinweis zu den AGBs:

Diese finden Sie in unserem Internetauftritt unter

**[www.heimatec.de](http://www.heimatec.de)**

Home/Impressum/AGB

Terms and conditions:

You will find them on our website

**[www.heimatec.com](http://www.heimatec.com)**

Home/Imprint/Terms and Conditions

Das Katalog-Werk einschließlich aller seiner Teile ist urheberrechtlich geschützt. Jede Verwertung außerhalb der engen Grenzen des Urheberrechtsgesetzes ist ohne Zustimmung der Rechteinhaber unzulässig und strafbar. Das gilt insbesondere für Vervielfältigungen, Übersetzungen, Mikroverfilmungen und die Einspeicherung und Verarbeitung in elektronischen Systemen.

**heimatec® GmbH** behält sich Änderungen technischer Art jederzeit ohne Vorankündigung vor. Dies gilt insbesondere bei Anpassungen an neue oder geänderte internationale Normen oder bei Weiterentwicklungen unserer Produkte oder Herstellungsprozesse.

This catalogue, including all its parts, is protected by copyright. Each use outside the restricted limitations of the Copyright Act is inadmissible and liable to prosecution without the consent of heimatec. This is particularly valid for duplication, translation, microfilming and feeding and processing in electronic systems.

**heimatec® GmbH** reserves the right of technical changes everytime without advance notice, which is particularly valid for adaptations to new or changed international standards, or to developments of our products or manufacturing processes.

angetriebene Werkzeuge  
driven tools

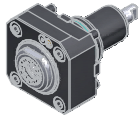

**Axial-Bohr- und Fräskopf**  
axial drilling and milling head

$n_{max} = 6000 \text{ min}^{-1}$

8 010 66 079	ER 32 AX u-tec	EK	1:1
8 010 66 081	ER 32 AX u-tec	IK 25 bar	1:1
8 010 66 046	ER 32 AX u-tec	IK 70 bar	1:1
8 010 67 025	easy quick HT 5	EK	1:1
8 010 67 026	easy quick HT 5	IK 25 bar	1:1
8 010 67 060	easy quick HT 5	IK 70 bar	1:1

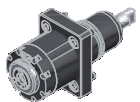

**Axial-Bohr- und Fräskopf**  
axial drilling and milling head

$n_{max} = 24000 \text{ min}^{-1}$

8 013 64 008	ER 16 AX u-tec	EK	1:4
8 013 64 009	ER 16 AX u-tec	IK 70 bar	1:4



**Axial-Bohr- und Fräskopf**  
axial drilling and milling head

$n_{max} = 6000 \text{ min}^{-1}$

8 011 65 014	Kombidorn/universal arbor 22	EK 1:1	
8 011 65 011	Kombidorn/universal arbor 1"	EK 1:1	



**Winkel-Bohr- und Fräskopf**  
radial drilling and milling head

Achsversatz / offset  $A=50$

8 019 65 021	ER 25 AX u-tec	EK	1:1
8 019 65 019	ER 25 AX u-tec	IK 70 bar	1:1
$n_{max} = 6000 \text{ min}^{-1}$			
8 019 65 004	ER 25 AX u-tec	EK	1:2
8 019 65 027	ER 25 AX u-tec	IK 70 bar	1:2
$n_{max} = 12000 \text{ min}^{-1}$			
8 019 65 025	ER 25 AX u-tec	EK	1:3
8 019 65 026	ER 25 AX u-tec	IK 70 bar	1:3
$n_{max} = 15000 \text{ min}^{-1}$			
8 019 65 023	ER 25 AX u-tec	EK	2:1
8 019 65 024	ER 25 AX u-tec	IK 70 bar	2:1
$n_{max} = 3000 \text{ min}^{-1}$			

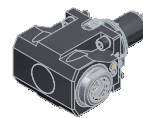
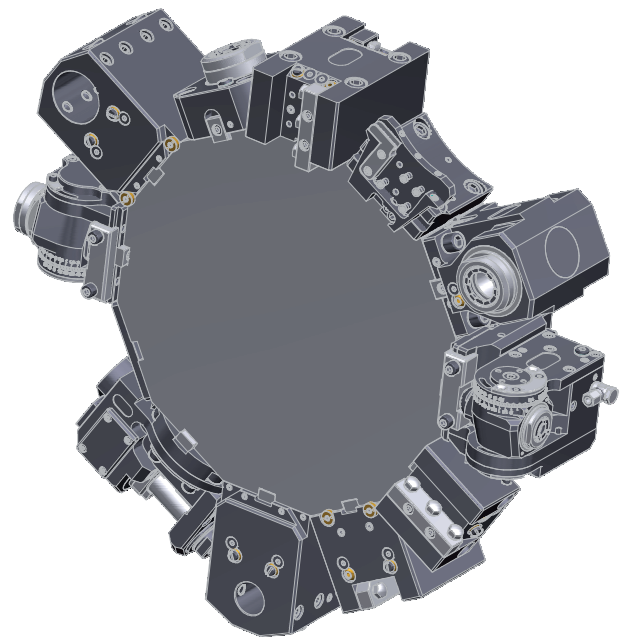

**Winkel-Bohr- und Fräskopf**  
radial drilling and milling head

Mittenmaß / center distance  $H=72$   
 $n_{max} = 6000 \text{ min}^{-1}$

8 030 66 097	ER 32 AX u-tec	EK	1:1
8 030 66 098	ER 32 AX u-tec	IK 140 bar	1:1
8 030 67 025	easy quick HT 5	EK	1:1
8 030 67 075	easy quick HT 5	IK 140 bar	1:1

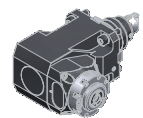

**Winkel-Bohr- und Fräskopf**  
radial drilling and milling head

Mittenmaß / center distance  $H=72$   
 $n_{max} = 24000 \text{ min}^{-1}$

8 030 64 021	ER 16 AX u-tec	EK	1:4
8 030 64 023	ER 16 AX u-tec	IK 140 bar	1:4



**Winkel-Bohr- und Fräskopf**  
radial drilling and milling head

Mittenmaß / center distance  $H=95$

8 030 65 055	ER 25 AX u-tec	EK	1:2
8 030 65 063	ER 25 AX u-tec	IK 140 bar	1:2
$n_{max} = 12000 \text{ min}^{-1}$			
8 030 65 064	ER 25 AX u-tec	EK	1:3
8 030 65 065	ER 25 AX u-tec	IK 140 bar	1:3
$n_{max} = 18000 \text{ min}^{-1}$			

► Weitere Ausführungen auf Anfrage  
further versions on request

► Zubehör ZB...\*  
accessories ZB...\*

► easy-quick



► u-tec



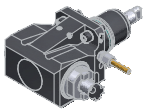

**Winkel-Bohr- und Fräskopf**  
radial drilling and milling head

Mittenmaß / center distance  $H=70$   
 $n_{max} = 6000 \text{ min}^{-1}$

8 031 65 015	<b>Kombidorn/universal arbor 22</b>	EK	1:1
8 031 65 010	<b>Kombidorn/universal arbor 1"</b>	EK	1:1



**Winkel-Bohr- und Fräskopf**  
radial drilling and milling head

Mittenmaß / center distance  $H=72$   
 $n_{max} = 6000 \text{ min}^{-1}$   
doppelspindlig / double spindle

8 039 66 025	<b>ER 32 AX u-tec</b>	EK	1:1
8 039 67 009	<b>easy quick HT 5</b>	IK 140 bar	1:1



**Schwenkkopf**  
universal head

Mittenmaß / center distance  $H=69$   
Achsversatz / offset  $A=60$

8 043 65 000	<b>ER 25 AX u-tec</b>	EK	1:1
8 043 65 004	<b>ER 25 AX u-tec</b>	IK 140 bar	1:1
	$n_{max} = 6000 \text{ min}^{-1}$		
8 043 64 008	<b>ER 16 AX u-tec</b>	EK	1:2
8 043 64 009	<b>ER 16 AX u-tec</b>	IK 140 bar	1:2
	$n_{max} = 12000 \text{ min}^{-1}$		

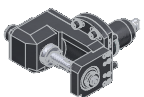

**Winkel-Scheibenfräserkopf** **±10° drehbar**  
radial disk mill head **±10° turnable**

Mittenmaß / center distance  $H=87,5$   
auf 0° absteckbar / 0° can be pinned  
kein Kühlmittel / no coolant  
 $n_{max} = 3000 \text{ min}^{-1}$

8 037 64 023	<b>∅ 16</b>	2:1
8 037 65 008	<b>∅ 22</b>	2:1
8 037 64 003	<b>∅ 3/4"</b>	2:1
8 037 65 019	<b>∅ 1"</b>	2:1

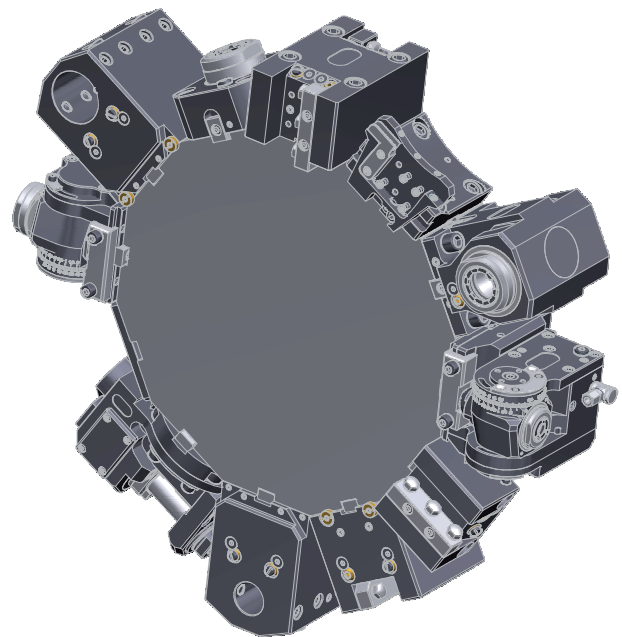

▶ Weitere Ausführungen auf Anfrage  
further versions on request

▶ Zubehör **ZB...\***  
accessories **ZB...\***



▶ **easy-quick**



▶ **u-tec**



feste Werkzeuge  
static tool holders

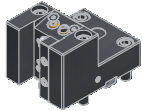

Kombi-Drehstahlhalter  
universal turning holder

8 224 15 006 Vierkant/square 25 EK  
8 224 15 016 Vierkant/square 1" EK

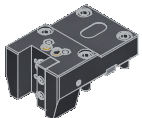

Kombi-Drehstahlhalter  
universal turning holder

8 224 15 005 Vierkant/square 25 EK  
8 224 15 015 Vierkant/square 1" EK

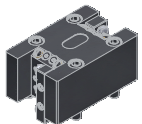

Kombi-Doppel-Drehstahlhalter  
combi double turning holder

8 251 15 003 Vierkant/square 25 EK  
8 251 15 008 Vierkant/square 1" EK

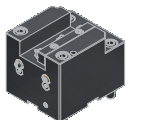

Kombi-Plandrehhalter  
combi facing holder

8 244 15 005 Vierkant/square 25 EK  
8 244 15 006 Vierkant/square 1" EK

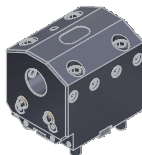

Bohrstangenhalter  
boring bar holder

Mittenmaß / center distance H=72

8 240 18 028  $\varnothing 32$  IK/EK  
8 240 19 032  $\varnothing 40$  IK/EK  
8 240 19 044  $\varnothing 1,5''$  IK/EK  
8 240 19 048  $\varnothing 2''$  IK/EK

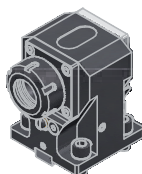

Spannzangenhalter  
collet chuck holder

Mittenmaß / center distance H=72

8 240 16 021 ER 32 IK/EK

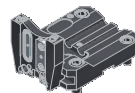
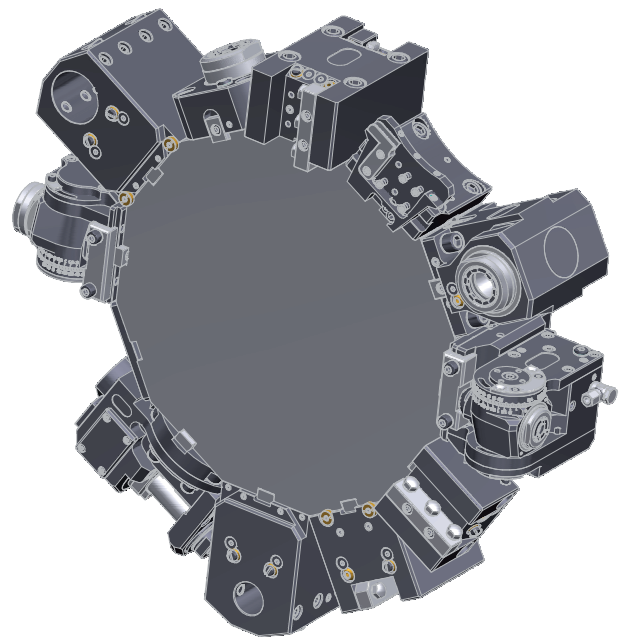

Abstechhalter  
cut-off holder

höhenverstellbar / height adjustable

8 320 12 017 SH 26 (1) IK 70 bar  
8 320 12 018 SH 26 (2) IK 70 bar  
8 320 13 005 SH 32 (1) IK 70 bar  
8 320 13 020 SH 32 (2) IK 70 bar

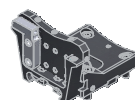
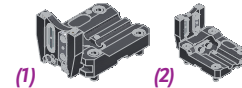

Abstechhalter  
cut-off holder

pl HORN pl

höhenverstellbar / height adjustable

8 320 19 000 HORN System 845 (1) IK 70 bar  
8 320 19 020 HORN System 845 (2) IK 70 bar

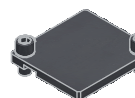
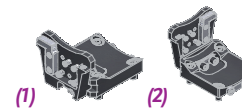

Abdeckplatte  
cover plate

8 200 03 005

► Weitere Ausführungen auf Anfrage  
further versions on request

► Zubehör ZB...\*  
accessories ZB...\*

► easy-quick



► u-tec



► **easy-quick HT Schnellwechselsystem**  
*easy-quick HT fast change system*

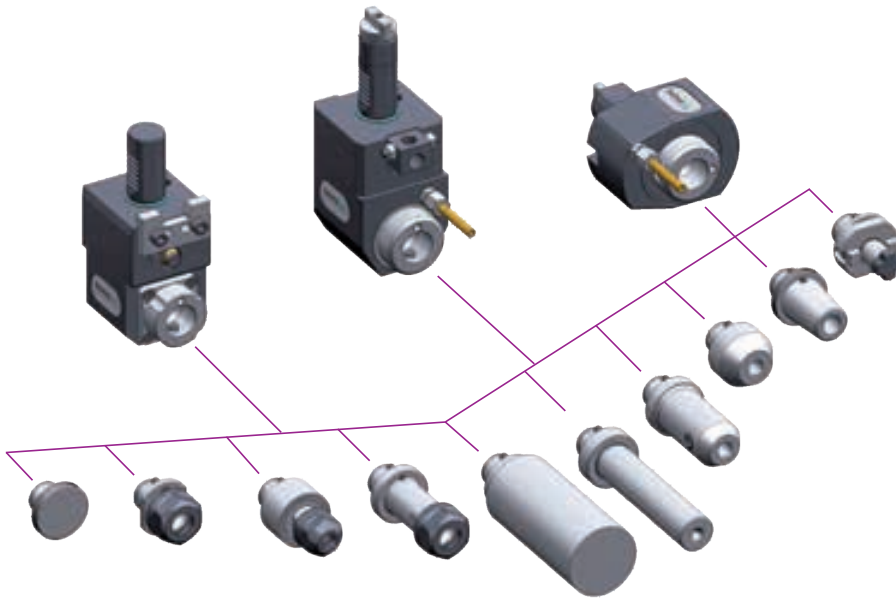

DAS Schnellwechselsystem von heimatec  
für angetriebene und feste Werkzeuge

*THE fast change system of heimatec  
for driven and static tools*

[www.heimatec.de](http://www.heimatec.de)  
Produkte / easy-quick

[www.heimatec.com](http://www.heimatec.com)  
products / easy-quick

► Ausführungen siehe Katalog  
versions see catalogue



► **u-tec<sup>®</sup> UT Wechselsystem**  
**u-tec<sup>®</sup> UT change system**

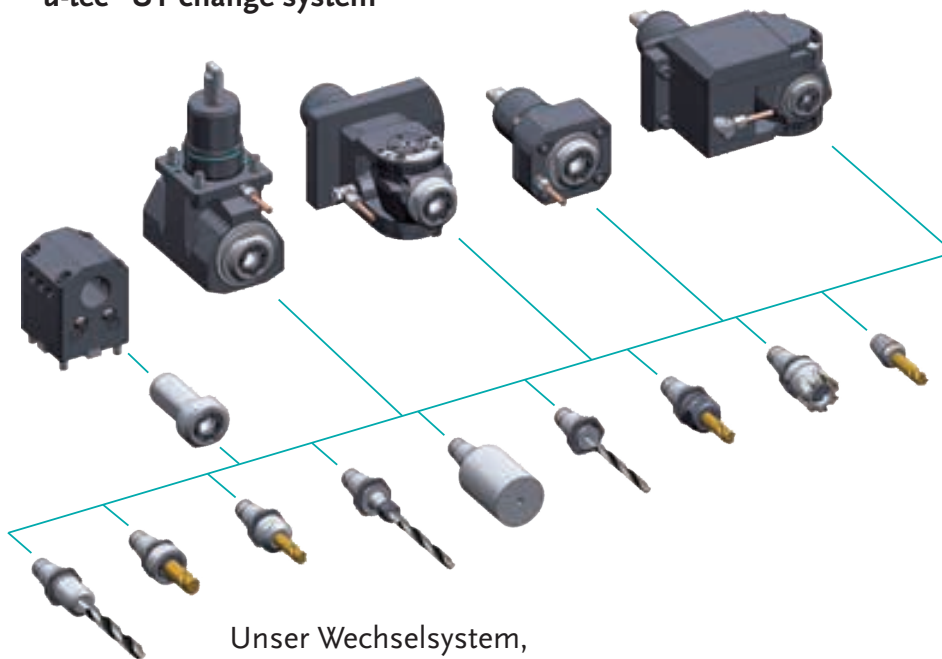

Unser Wechselsystem,  
das ALLES möglich macht

Our change system,  
that makes EVERYTHING possible

[www.heimatec.de](http://www.heimatec.de)  
Produkte / u-tec

[www.heimatec.com](http://www.heimatec.com)  
products / u-tec

► Ausführungen siehe Katalog  
versions see catalogue





# heimatec®

- heimatec®-Niederlassungen  
*heimatec® overseas branches*
- unsere weltweiten Vertretungen  
*global representations of heimatec®*



## Hauptsitz/headquarters

heimatec® GmbH  
Präzisionswerkzeuge  
Carl-Benz-Straße 4  
D- 77871 Renchen  
Postfach 11 36  
D- 77867 Renchen

Tel.: +49 (78 43) 94 66 0  
Fax: +49 (78 43) 94 66 66  
heimatec.de  
info@heimatec.de

heimatec® Inc.  
USA  
usa.heimatec.com  
USA@heimatec.com

heimatec®-Ost, JSC  
Russia  
ru.heimatec.com  
Russia@heimatec.com

heimatec® Ltd.  
Taiwan  
tw.heimatec.com  
Taiwan@heimatec.com

heimatec®  
Singapore  
sg.heimatec.com  
Singapore@heimatec.com

heimatec® India Pvt Ltd.  
India  
in.heimatec.com  
India@heimatec.com





# Werkzeugkatalog

tool catalogue

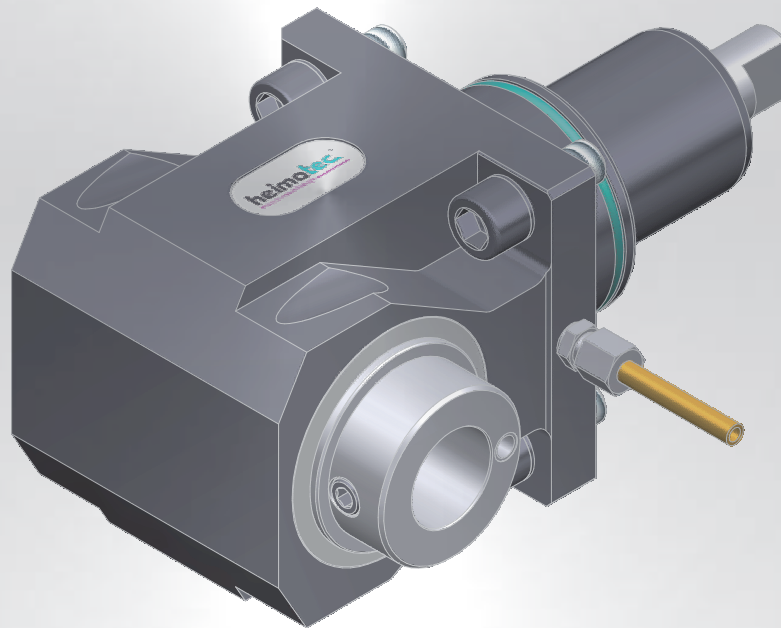

# Hwacheon

BMT 65

Hi-TECH 450 MC



Hinweis zu den AGBs:

Diese finden Sie in unserem Internetauftritt unter

**[www.heimatec.de](http://www.heimatec.de)**

Home/Impressum/AGB

Terms and conditions:

You will find them on our website

**[www.heimatec.com](http://www.heimatec.com)**

Home/Imprint/Terms and Conditions

Das Katalog-Werk einschließlich aller seiner Teile ist urheberrechtlich geschützt. Jede Verwertung außerhalb der engen Grenzen des Urheberrechtsgesetzes ist ohne Zustimmung der Rechteinhaber unzulässig und strafbar. Das gilt insbesondere für Vervielfältigungen, Übersetzungen, Mikroverfilmungen und die Einspeicherung und Verarbeitung in elektronischen Systemen.

**heimatec® GmbH** behält sich Änderungen technischer Art jederzeit ohne Vorankündigung vor. Dies gilt insbesondere bei Anpassungen an neue oder geänderte internationale Normen oder bei Weiterentwicklungen unserer Produkte oder Herstellungsprozesse.

This catalogue, including all its parts, is protected by copyright. Each use outside the restricted limitations of the Copyright Act is inadmissible and liable to prosecution without the consent of heimatec. This is particularly valid for duplication, translation, microfilming and feeding and processing in electronic systems.

**heimatec® GmbH** reserves the right of technical changes everytime without advance notice, which is particularly valid for adaptations to new or changed international standards, or to developments of our products or manufacturing processes.

## angetriebene Werkzeuge

### driven tools



#### Axial-Bohr- und Fräskopf

#### axial drilling and milling head

$n_{max} = 6000 \text{ min}^{-1}$

8 010 66 079	ER 32 AX u-tec	EK	1:1
8 010 66 081	ER 32 AX u-tec	IK 25 bar	1:1
8 010 66 046	ER 32 AX u-tec	IK 70 bar	1:1
8 010 67 025	easy-quick HT 5	EK	1:1
8 010 67 026	easy-quick HT 5	IK 25 bar	1:1
8 010 67 060	easy-quick HT 5	IK 70 bar	1:1

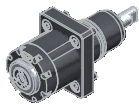

#### Axial-Bohr- und Fräskopf

#### axial drilling and milling head

$n_{max} = 24000 \text{ min}^{-1}$

8 013 64 008	ER 16 AX u-tec	EK	1:4
8 013 64 009	ER 16 AX u-tec	IK 70 bar	1:4



#### Axial-Bohr- und Fräskopf

#### axial drilling and milling head

$n_{max} = 6000 \text{ min}^{-1}$

8 011 65 014	Kombidorn/universal arbor 22	EK	1:1
8 011 65 011	Kombidorn/universal arbor 1"	EK	1:1



#### Axial-Bohr- und Fräskopf

#### axial drilling and milling head

Achsversatz / offset  $A=50$

8 019 65 021	ER 25 AX u-tec	EK	1:1
8 019 65 022	ER 25 AX u-tec	IK 140 bar	1:1
$n_{max} = 6000 \text{ min}^{-1}$			
8 019 65 004	ER 25 AX u-tec	EK	1:2
8 019 65 027	ER 25 AX u-tec	IK 140 bar	1:2
$n_{max} = 12000 \text{ min}^{-1}$			
8 019 65 023	ER 25 AX u-tec	EK	2:1
8 019 65 024	ER 25 AX u-tec	IK 140 bar	2:1
$n_{max} = 3000 \text{ min}^{-1}$			
8 019 65 025	ER 25 AX u-tec	EK	1:3
8 019 65 026	ER 25 AX u-tec	IK 140 bar	1:3
$n_{max} = 15000 \text{ min}^{-1}$			

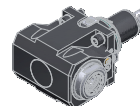
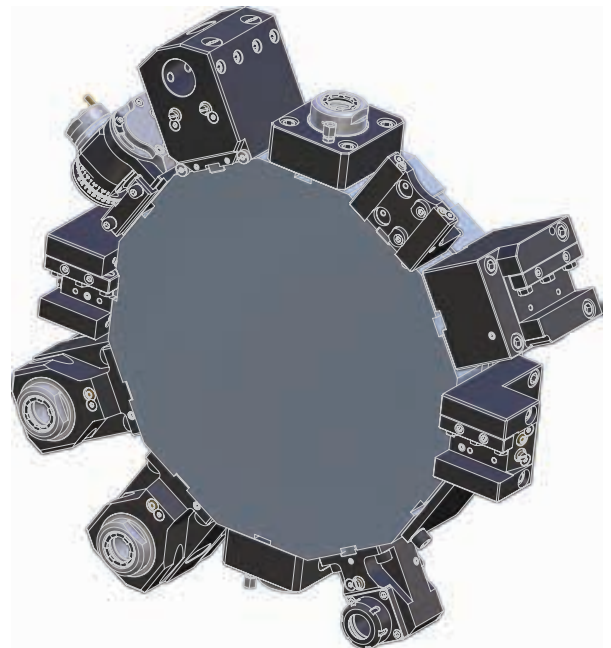

#### Winkel-Bohr- und Fräskopf

#### radial drilling and milling head

Mittenmaß / center distance  $H=72$   
 $n_{max} = 6000 \text{ min}^{-1}$

8 030 66 097	ER 32 AX u-tec	EK	1:1
8 030 66 098	ER 32 AX u-tec	IK 140 bar	1:1
8 030 67 025	easy-quick HT 5	EK	1:1
8 030 67 075	easy-quick HT 5	IK 140 bar	1:1

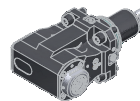

#### Axial-Bohr- und Fräskopf

#### axial drilling and milling head

Mittenmaß / center distance  $H=95$

8 030 65 055	ER 25 AX u-tec	EK	1:2
8 030 65 063	ER 25 AX u-tec	IK 140 bar	1:2
$n_{max} = 12000 \text{ min}^{-1}$			
8 030 65 064	ER 25 AX u-tec	EK	1:3
8 030 65 065	ER 25 AX u-tec	IK 140 bar	1:3
$n_{max} = 18000 \text{ min}^{-1}$			

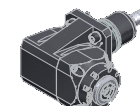

#### Winkel-Bohr- und Fräskopf

#### radial drilling and milling head

Mittenmaß / center distance  $H=72$   
 $n_{max} = 24000 \text{ min}^{-1}$

8 030 64 021	ER 16 AX u-tec	EK	1:4
8 030 64 023	ER 16 AX u-tec	IK 140 bar	1:4

► Weitere Ausführungen auf Anfrage  
further versions on request

► Zubehör ZB...\*  
accessories ZB...\*

► easy-quick



► u-tec



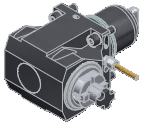

### Winkel-Bohr- und Fräskopf radial drilling and milling head

Mittenmaß / center distance  $H=72$   
 $n_{max} = 6000 \text{ min}^{-1}$

8 031 65 015	Kombidorn/universal arbor 22	EK	1:1
8 031 65 010	Kombidorn/universal arbor 1"	EK	1:1

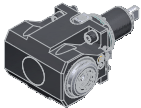

### Winkel-Bohr- und Fräskopf radial drilling and milling head

Mittenmaß / center distance  $H=72$   
doppelspindlig / double spindle  
 $n_{max} = 6000 \text{ min}^{-1}$

8 039 66 025	ER 32 AX u-tec	EK	1:1
8 039 67 009	easy-quick HT 5	EK	1:1

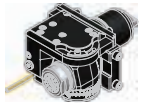

### Schwenkkopf universal head

Mittenmaß / center distance  $H=69$   
Achsversatz / offset  $A=60$

8 043 65 000	ER 25 AX u-tec	EK	1:1
8 043 65 004	ER 25 AX u-tec	IK 140 bar	1:1
$n_{max} = 6000 \text{ min}^{-1}$			
8 043 64 008	ER 16 AX u-tec	EK	1:2
8 043 64 009	ER 16 AX u-tec	IK 140 bar	1:2
$n_{max} = 12000 \text{ min}^{-1}$			

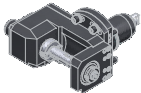

### Winkel-Scheibenfräserkopf radial disk mill head

$\pm 10^\circ$  drehbar  
 $\pm 10^\circ$  turnable

Mittenmaß / center distance  $H=87,5$   
auf  $0^\circ$  absteckbar /  $0^\circ$  can be pinned  
kein Kühlmittel / no coolant  
 $n_{max} = 3000 \text{ min}^{-1}$

8 037 64 023	$\varnothing 16$	2:1
8 037 65 008	$\varnothing 22$	2:1
8 037 64 003	$\varnothing 3/4"$	2:1
8 037 65 019	$\varnothing 1"$	2:1

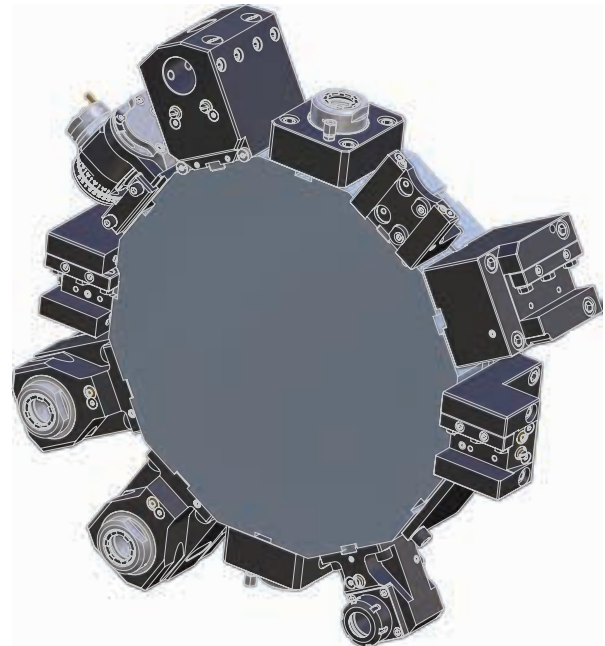

► Weitere Ausführungen auf Anfrage  
further versions on request

► Zubehör ZB...\*  
accessories ZB...\*



► easy-quick



► u-tec



feste Werkzeuge  
static tool holders

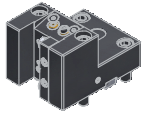

Kombi-Drehstahlhalter  
universal turning holder

8 224 15 006 Vierkant/square 25 EK  
8 224 15 016 Vierkant/square 1" EK

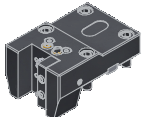

Kombi-Drehstahlhalter  
universal turning holder

8 224 15 005 Vierkant/square 25 EK  
8 224 15 015 Vierkant/square 1" EK

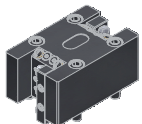

Kombi-Doppel-Drehstahlhalter  
combi double turning holder

8 251 15 003 Vierkant/square 25 EK  
8 251 15 008 Vierkant/square 1" EK

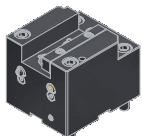

Kombi-Plandrehhalter  
combi facing holder

8 244 15 005 Vierkant/square 25 EK  
8 244 15 006 Vierkant/square 1" EK



Bohrstangenhalter  
boring bar holder

Mittenmaß / center distance H=72

8 240 18 028 ø32 IK/EK  
8 240 19 032 ø40 IK/EK  
8 240 19 044 ø1,5" IK/EK  
8 240 19 048 ø2" IK/EK

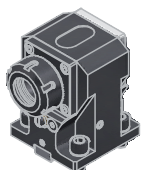

Spannzangenhalter  
collet chuck holder

Mittenmaß / center distance H=72

8 240 16 021 ER 32 IK/EK

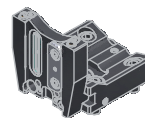
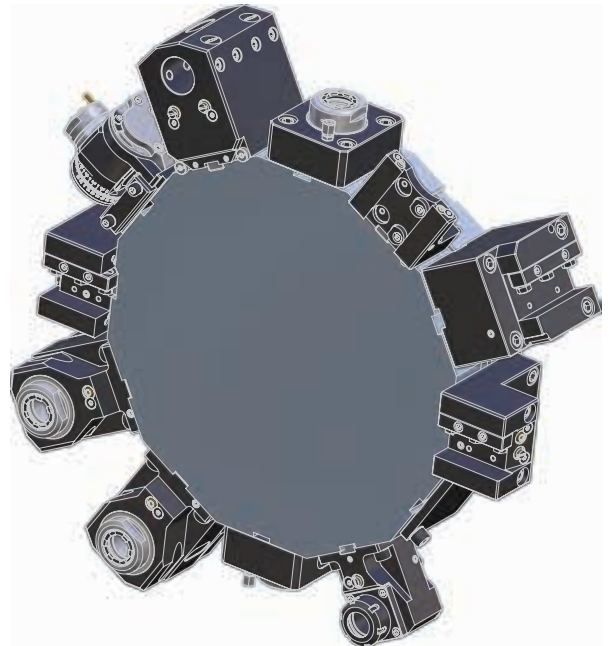

Abstechhalter  
cut-off holder

höhenverstellbar / height adjustable

8 320 13 005 SH 32 IK 70 bar

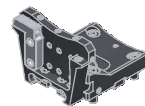

Abstechhalter  
cut-off holder

höhenverstellbar / height adjustable

8 320 19 000 HORN System 845 IK 70 bar

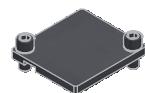

Abdeckblech  
cover plate

8 200 03 005

► Weitere Ausführungen auf Anfrage  
further versions on request

► Zubehör ZB...\*  
accessories ZB...\*

► easy-quick

► u-tec

► **easy-quick HT Schnellwechselsystem**  
*easy-quick HT fast change system*

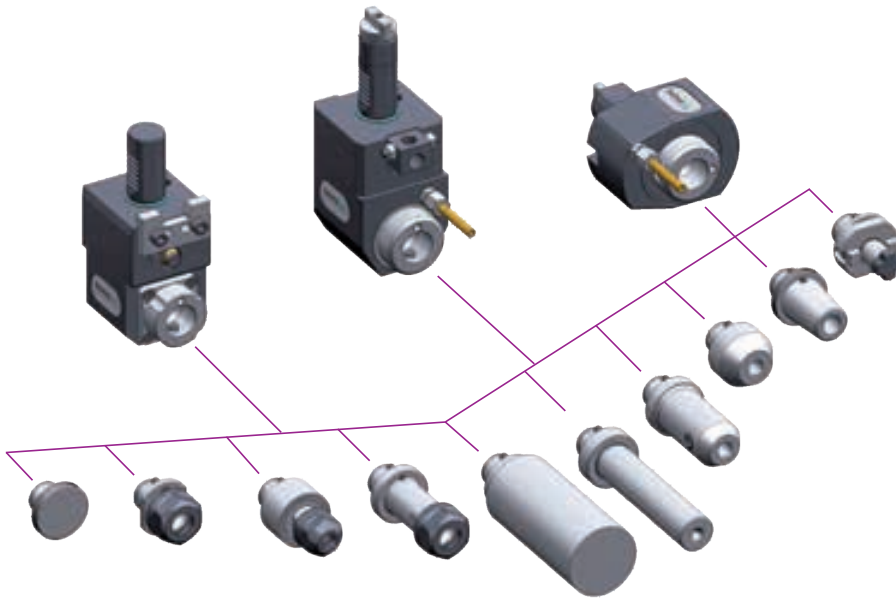

DAS Schnellwechselsystem von heimatec  
für angetriebene und feste Werkzeuge

*THE fast change system of heimatec  
for driven and static tools*

[www.heimatec.de](http://www.heimatec.de)  
Produkte / easy-quick

[www.heimatec.com](http://www.heimatec.com)  
products / easy-quick

► Ausführungen siehe Katalog  
versions see catalogue



► **u-tec<sup>®</sup> UT Wechselsystem**  
**u-tec<sup>®</sup> UT change system**

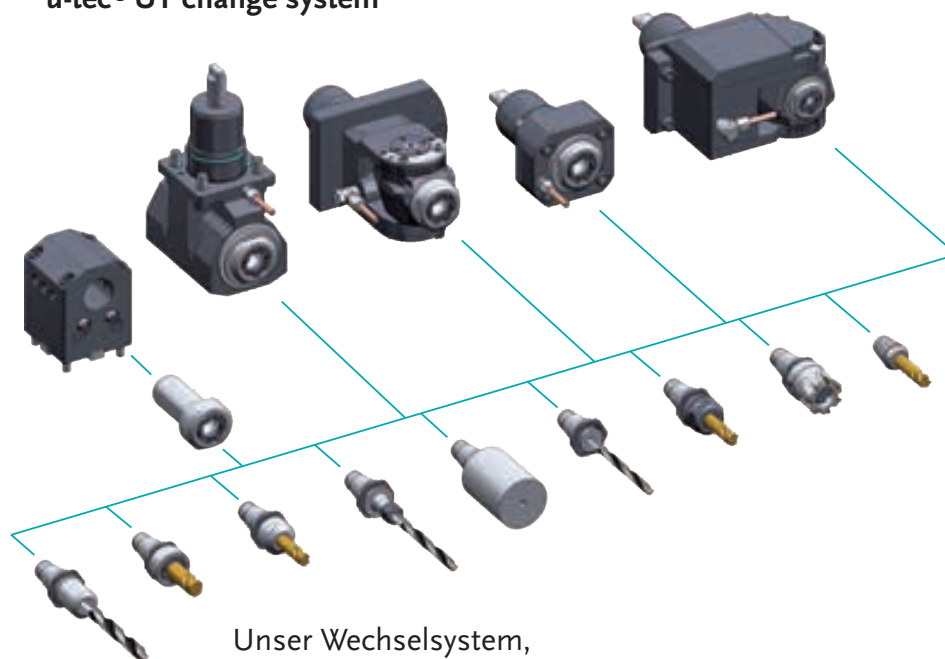

Unser Wechselsystem,  
das ALLES möglich macht

Our change system,  
that makes EVERYTHING possible

[www.heimatec.de](http://www.heimatec.de)  
Produkte / u-tec

[www.heimatec.com](http://www.heimatec.com)  
products / u-tec

► Ausführungen siehe Katalog  
versions see catalogue



**▶ Zubehör**  
accessories



**▶ Ausführungen siehe Katalog**  
versions see catalogue



[www.heimatec.de](http://www.heimatec.de)  
Produkte / Zubehör

[www.heimatec.com](http://www.heimatec.com)  
products / accessories

**Notizen**  
notes

---



---



---



---



---



---



---



---



---



---



---



---



---



---



---



---



---



---



---



---



---



---



---

# heimatec®

- heimatec®-Niederlassungen  
*heimatec® overseas branches*
- unsere weltweiten Vertretungen  
*global representations of heimatec®*



## Hauptsitz/headquarters

heimatec® GmbH  
Präzisionswerkzeuge  
Carl-Benz-Straße 4  
D- 77871 Renchen  
Postfach 11 36  
D- 77867 Renchen

Tel.: +49 (78 43) 94 66 0  
Fax: +49 (78 43) 94 66 66  
heimatec.de  
info@heimatec.de

heimatec® Inc.  
USA  
usa.heimatec.com  
USA@heimatec.com

heimatec®-Ost, JSC  
Russia  
ru.heimatec.com  
Russia@heimatec.com

heimatec® Ltd.  
Taiwan  
tw.heimatec.com  
Taiwan@heimatec.com

heimatec®  
Singapore  
sg.heimatec.com  
Singapore@heimatec.com

heimatec® India Pvt Ltd.  
India  
in.heimatec.com  
India@heimatec.com





# Werkzeugkatalog

tool catalogue

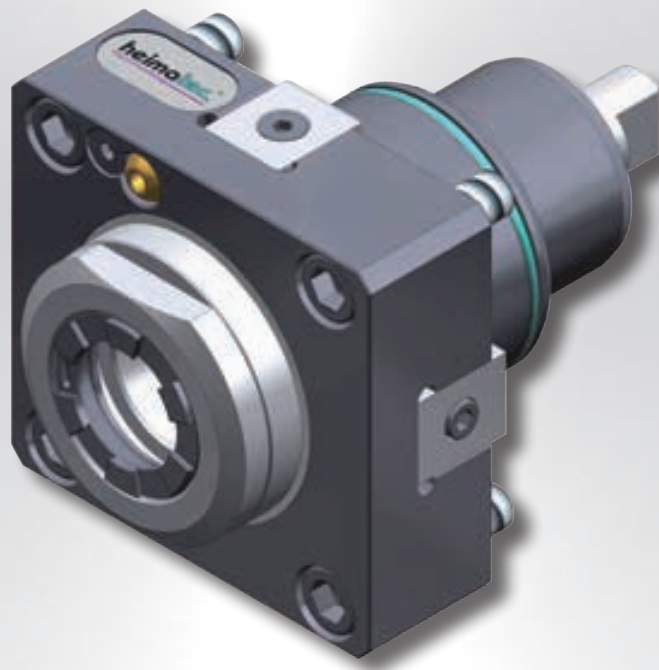

# Hwacheon

BMT 75

Hi-TECH 550 MC



Hinweis zu den AGBs:

Diese finden Sie in unserem Internetauftritt unter

**[www.heimatec.de](http://www.heimatec.de)**

Home/Impressum/AGB

Terms and conditions:

You will find them on our website

**[www.heimatec.com](http://www.heimatec.com)**

Home/Imprint/Terms and Conditions

Das Katalog-Werk einschließlich aller seiner Teile ist urheberrechtlich geschützt. Jede Verwertung außerhalb der engen Grenzen des Urheberrechtsgesetzes ist ohne Zustimmung der Rechteinhaber unzulässig und strafbar. Das gilt insbesondere für Vervielfältigungen, Übersetzungen, Mikroverfilmungen und die Einspeicherung und Verarbeitung in elektronischen Systemen.

**heimatec® GmbH** behält sich Änderungen technischer Art jederzeit ohne Vorankündigung vor. Dies gilt insbesondere bei Anpassungen an neue oder geänderte internationale Normen oder bei Weiterentwicklungen unserer Produkte oder Herstellungsprozesse.

This catalogue, including all its parts, is protected by copyright. Each use outside the restricted limitations of the Copyright Act is inadmissible and liable to prosecution without the consent of heimatec. This is particularly valid for duplication, translation, microfilming and feeding and processing in electronic systems.

**heimatec® GmbH** reserves the right of technical changes everytime without advance notice, which is particularly valid for adaptations to new or changed international standards, or to developments of our products or manufacturing processes.

**angetriebene Werkzeuge**  
**driven tools**



**Axial-Bohr- und Fräskopf**  
**axial drilling and milling head**

$n_{max} = 4000 \text{ min}^{-1}$

8 010 67 059	<b>ER 40 AX u-tec</b>	EK	1:1
8 010 67 039	<b>ER 40 AX u-tec</b>	IK 25 bar	1:1
8 010 67 061	<b>ER 40 AX u-tec</b>	IK 140 bar	1:1
8 010 68 031	<b>easy quick HT 6</b>	EK	1:1
8 010 68 032	<b>easy quick HT 6</b>	IK 25 bar	1:1
8 010 68 037	<b>easy quick HT 6</b>	IK 140 bar	1:1

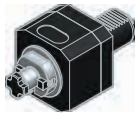

**Axial-Bohr- und Fräskopf**  
**axial drilling and milling head**

$n_{max} = 4000 \text{ min}^{-1}$

8 011 65 007	<b>Kombidorn/universal arbor 22</b>	EK 1:1	
--------------	-------------------------------------	--------	--

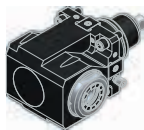

**Winkel-Bohr- und Fräskopf**  
**radial drilling and milling head**

*Mittenmaß / center distance H=90*  
 $n_{max} = 4000 \text{ min}^{-1}$

8 030 67 074	<b>ER 40 AX u-tec</b>	EK	1:1
8 030 67 071	<b>ER 40 AX u-tec</b>	IK 140 bar	1:1
8 030 68 023	<b>easy quick HT 6</b>	EK	1:1
8 030 68 022	<b>easy quick HT 6</b>	IK 140 bar	1:1



► Weitere Ausführungen auf Anfrage  
 further versions on request

► Zubehör **ZB...\***  
 accessories **ZB...\***

► **easy-quick**

► **u-tec**

**feste Werkzeuge**  
static tool holders

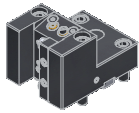

**Kombi-Drehstahlhalter**  
universal turning holder

8 224 26 002 Vierkant/square 32 EK

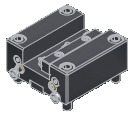

**Kombi-Plandrehhalter**  
combi facing holder

8 244 26 002 Vierkant/square 32 EK



**Bohrstangenhalter**  
boring bar holder

8 240 29 025  $\varnothing$  40 IK/EK

8 240 29 026  $\varnothing$  50 IK/EK

Mittenmaß / center distance H=100

8 240 29 020  $\varnothing$  60 IK/EK

Mittenmaß / center distance H=120

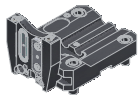

**Abstechhalter**  
cut-off holder

höhenverstellbar / height adjustable

8 320 23 011 SH 32 (1) IK 70 bar

8 320 23 025 SH 32 (2) IK 70 bar

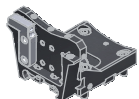
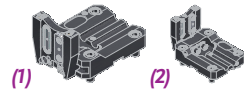

**Abstechhalter**  
cut-off holder



höhenverstellbar / height adjustable

8 320 29 000 HORN System 845 (1) IK 70 bar

8 320 29 006 HORN System 845 (2) IK 70 bar

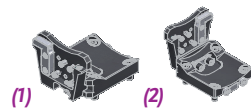

► Weitere Ausführungen auf Anfrage  
further versions on request

► Zubehör ZB...\*  
accessories ZB...\*



► easy-quick



► u-tec



- ▶ *easy-quick HT Schnellwechselsystem*  
*easy-quick HT fast change system*

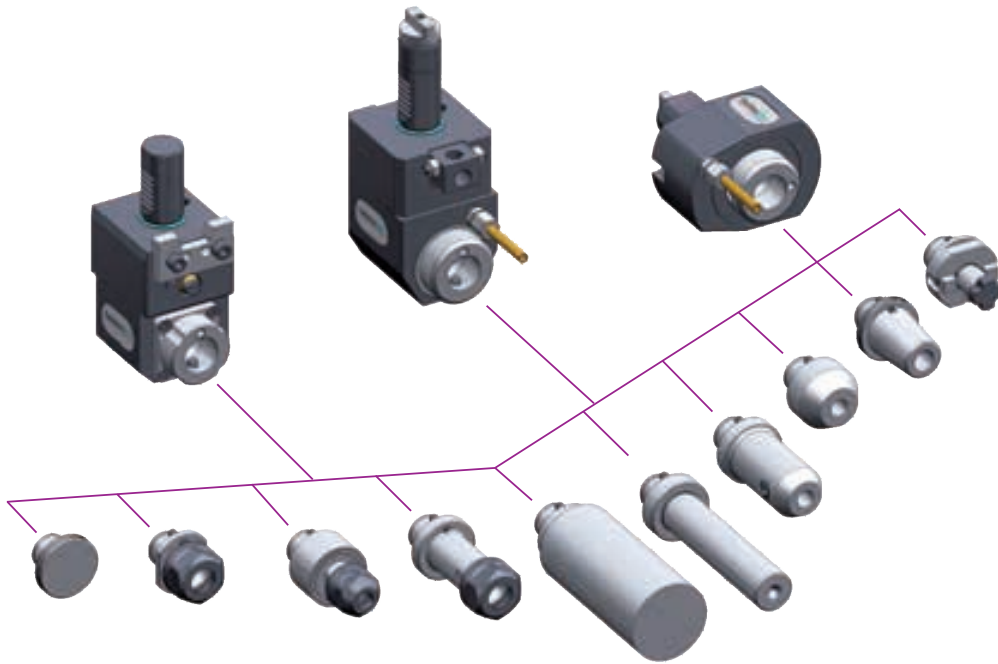

DAS Schnellwechselsystem von heimatec  
für angetriebene und feste Werkzeuge

*THE fast change system of heimatec  
for driven and static tools*

- ▶ Ausführungen siehe Katalog  
versions see catalogue

[www.heimatec.de](http://www.heimatec.de)  
Produkte / easy-quick

[www.heimatec.com](http://www.heimatec.com)  
products / easy-quick



► **u-tec<sup>®</sup> UT Wechselsystem**  
**u-tec<sup>®</sup> UT change system**

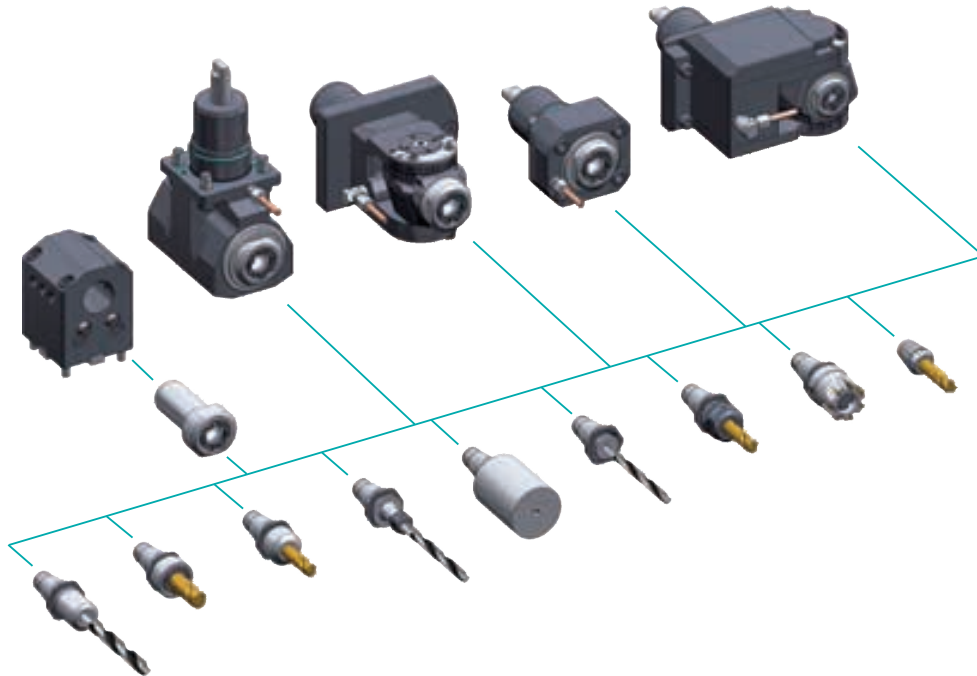

Unser Wechselsystem,  
das ALLES möglich macht

Our change system,  
that makes EVERYTHING possible

► Ausführungen siehe Katalog  
versions see catalogue



[www.heimatec.de](http://www.heimatec.de)  
Produkte / u-tec

[www.heimatec.com](http://www.heimatec.com)  
products / u-tec

► **Zubehör**  
accessories



► Ausführungen siehe Katalog  
versions see catalogue



[www.heimatec.de](http://www.heimatec.de)  
Produkte / Zubehör

[www.heimatec.com](http://www.heimatec.com)  
products / accessories

# heimatec®

- heimatec®-Niederlassungen  
*heimatec® overseas branches*
- unsere weltweiten Vertretungen  
*global representations of heimatec®*



## Hauptsitz/headquarters

heimatec® GmbH  
Präzisionswerkzeuge  
Carl-Benz-Straße 4  
D- 77871 Renchen  
Postfach 11 36  
D- 77867 Renchen

Tel.: +49 (78 43) 94 66 0  
Fax: +49 (78 43) 94 66 66  
heimatec.de  
info@heimatec.de

heimatec® Inc.  
USA  
usa.heimatec.com  
USA@heimatec.com

heimatec®-Ost, JSC  
Russia  
ru.heimatec.com  
Russia@heimatec.com

heimatec® Ltd.  
Taiwan  
tw.heimatec.com  
Taiwan@heimatec.com

heimatec®  
Singapore  
sg.heimatec.com  
Singapore@heimatec.com

heimatec® India Pvt Ltd.  
India  
in.heimatec.com  
India@heimatec.com





# Werkzeugkatalog

tool catalogue

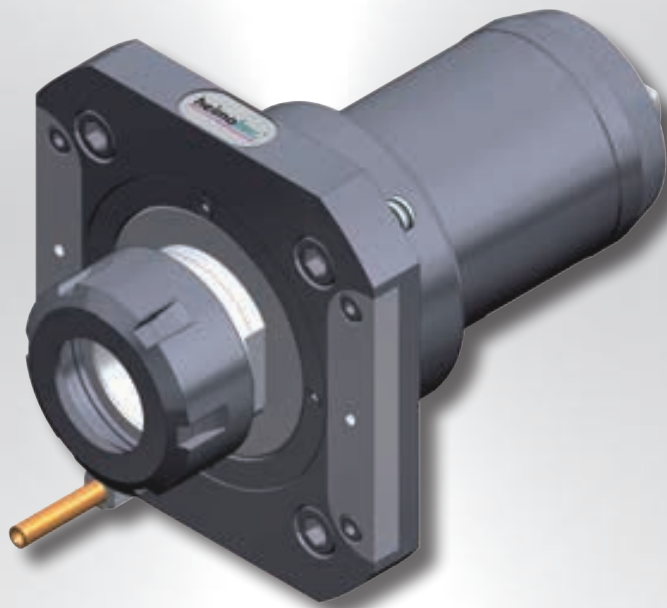

# Hwacheon

BMT 110

Hi-TECH 700 MC



Hinweis zu den AGBs:

Diese finden Sie in unserem Internetauftritt unter

**[www.heimatec.de](http://www.heimatec.de)**

Home/Impressum/AGB

Terms and conditions:

You will find them on our website

**[www.heimatec.com](http://www.heimatec.com)**

Home/Imprint/Terms and Conditions

Das Katalog-Werk einschließlich aller seiner Teile ist urheberrechtlich geschützt. Jede Verwertung außerhalb der engen Grenzen des Urheberrechtsgesetzes ist ohne Zustimmung der Rechteinhaber unzulässig und strafbar. Das gilt insbesondere für Vervielfältigungen, Übersetzungen, Mikroverfilmungen und die Einspeicherung und Verarbeitung in elektronischen Systemen.

**heimatec® GmbH** behält sich Änderungen technischer Art jederzeit ohne Vorankündigung vor. Dies gilt insbesondere bei Anpassungen an neue oder geänderte internationale Normen oder bei Weiterentwicklungen unserer Produkte oder Herstellungsprozesse.

This catalogue, including all its parts, is protected by copyright. Each use outside the restricted limitations of the Copyright Act is inadmissible and liable to prosecution without the consent of heimatec. This is particularly valid for duplication, translation, microfilming and feeding and processing in electronic systems.

**heimatec® GmbH** reserves the right of technical changes everytime without advance notice, which is particularly valid for adaptations to new or changed international standards, or to developments of our products or manufacturing processes.

**angetriebene Werkzeuge**  
**driven tools**

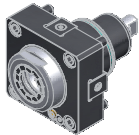

**Axial-Bohr- und Fräskopf**  
**axial drilling and milling head**

$n_{max} = 4000 \text{ min}^{-1}$

8 010 87 002	<b>ER 40 AX u-tec</b>	EK	1:1
8 010 87 003	<b>ER 40 AX u-tec</b>	IK 70 bar	1:1
8 010 88 000	<b>ER 50 CL</b>	EK	1:1
8 010 88 001	<b>ER 50 CL</b>	IK 70 bar	1:1
8 010 89 000	<b>easy quick HT 7</b>	EK	1:1
8 010 89 001	<b>easy quick HT 7</b>	IK 70 bar	1:1

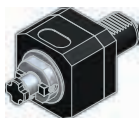

**Axial-Fräskopf**  
**axial milling head**

$n_{max} = 4000 \text{ min}^{-1}$

8 011 87 000	<b>Kombidorn/universal arbor 32</b>	EK	1:1
--------------	-------------------------------------	----	-----



**Winkel-Bohr- und Fräskopf**  
**radial drilling and milling head**

Mittenmaß / center distance  $H=70$   
 $n_{max} = 4000 \text{ min}^{-1}$

8 030 87 002	<b>ER 40 AX u-tec</b>	EK	1:1
8 030 87 003	<b>ER 40 AX u-tec</b>	IK 140 bar	1:1
8 030 88 000	<b>ER 50 CL</b>	EK	1:1
8 030 88 001	<b>ER 50 CL</b>	IK 140 bar	1:1
8 030 89 000	<b>easy quick HT 7</b>	EK	1:1
8 030 89 001	<b>easy quick HT 7</b>	IK 140 bar	1:1

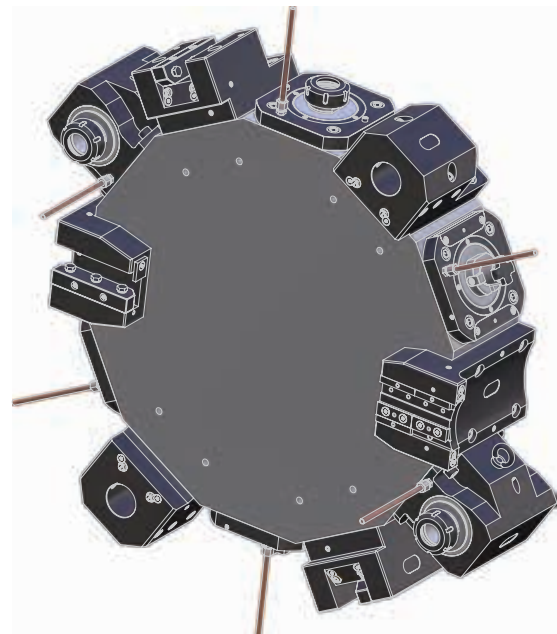

**feste Werkzeuge**  
**static tool holders**

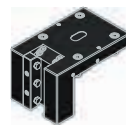

**Kombi-Drehstahlhalter**  
**universal turning holder**

8 224 06 001	<b>Vierkant/square 32</b>	EK
--------------	---------------------------	----

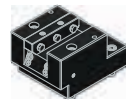

**Kombi-Plandrehhalter**  
**combi facing holder**

8 244 06 000	<b>Vierkant/square 32</b>	EK
--------------	---------------------------	----



**Bohrstangenhalter**  
**boring bar holder**

Mittenmaß / center distance  $H=70$

8 240 09 005	<b>∅ 50</b>	IK/EK
8 240 09 006	<b>∅ 60</b>	IK/EK



**Abstechhalter**  
**cut-off holder**

8 224 04 001	<b>SH 45</b>	EK
8 224 05 000	<b>SH 52,6</b>	EK

► Weitere Ausführungen auf Anfrage  
further versions on request

► Zubehör **ZB...\***  
accessories **ZB...\***

► **easy-quick**

► **u-tec**

- ▶ *easy-quick HT Schnellwechselsystem*  
*easy-quick HT fast change system*

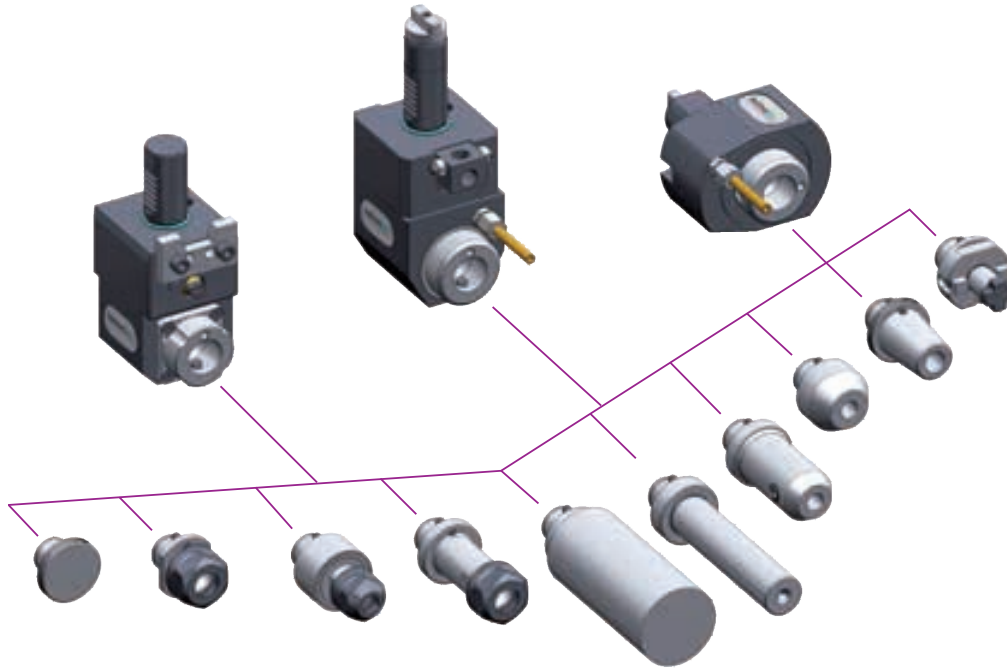

- ▶ Ausführungen siehe Katalog  
versions see catalogue

DAS Schnellwechselsystem von heimatec  
für angetriebene und feste Werkzeuge

*THE fast change system of heimatec  
for driven and static tools*

[www.heimatec.de](http://www.heimatec.de)  
Produkte / easy-quick

[www.heimatec.com](http://www.heimatec.com)  
products / easy-quick



► **u-tec<sup>®</sup> UT Wechselsystem**  
**u-tec<sup>®</sup> UT change system**

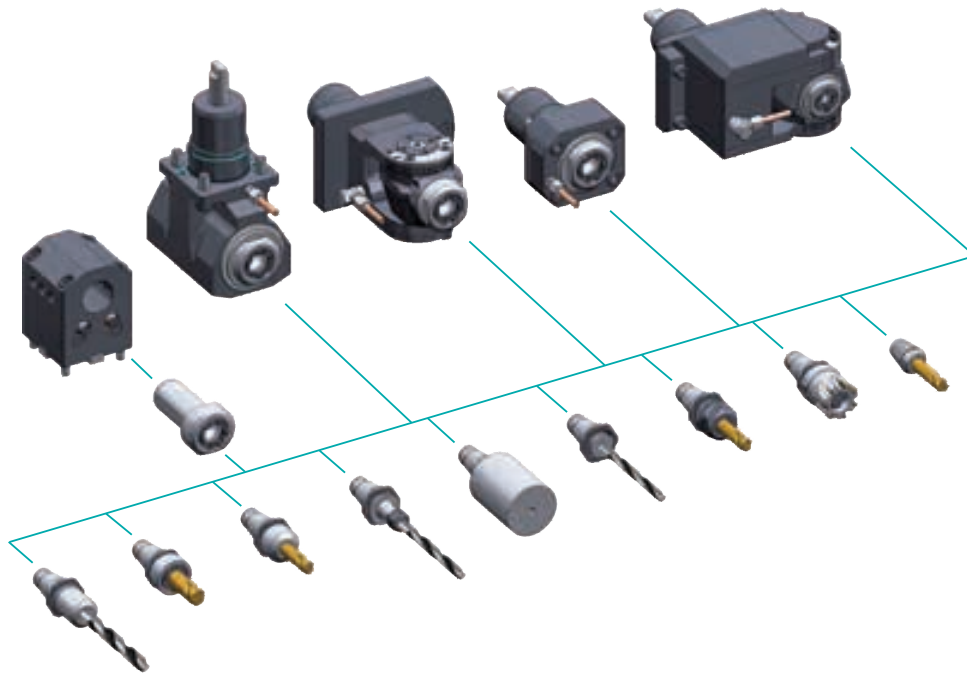

► Ausführungen siehe Katalog  
versions see catalogue

Unser Wechselsystem,  
das ALLES möglich macht

Our change system,  
that makes EVERYTHING possible

[www.heimatec.de](http://www.heimatec.de)  
Produkte / u-tec

[www.heimatec.com](http://www.heimatec.com)  
products / u-tec



► **Zubehör**  
accessories



► Ausführungen siehe Katalog  
versions see catalogue

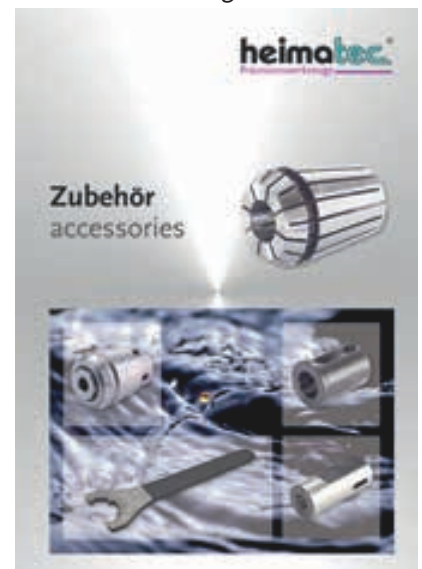

[www.heimatec.de](http://www.heimatec.de)  
Produkte / Zubehör

[www.heimatec.com](http://www.heimatec.com)  
products / accessories



# heimatec®

- heimatec®-Niederlassungen  
*heimatec® overseas branches*
- unsere weltweiten Vertretungen  
*global representations of heimatec®*



## Hauptsitz/headquarters

heimatec® GmbH  
Präzisionswerkzeuge  
Carl-Benz-Straße 4  
D- 77871 Renchen  
Postfach 11 36  
D- 77867 Renchen

Tel.: +49 (78 43) 94 66 0  
Fax: +49 (78 43) 94 66 66  
heimatec.de  
info@heimatec.de

heimatec® Inc.  
USA  
usa.heimatec.com  
USA@heimatec.com

heimatec®-Ost, JSC  
Russia  
ru.heimatec.com  
Russia@heimatec.com

heimatec® Ltd.  
Taiwan  
tw.heimatec.com  
Taiwan@heimatec.com

heimatec®  
Singapore  
sg.heimatec.com  
Singapore@heimatec.com

heimatec® India Pvt Ltd.  
India  
in.heimatec.com  
India@heimatec.com





**Werkzeugkatalog**  
tool catalogue

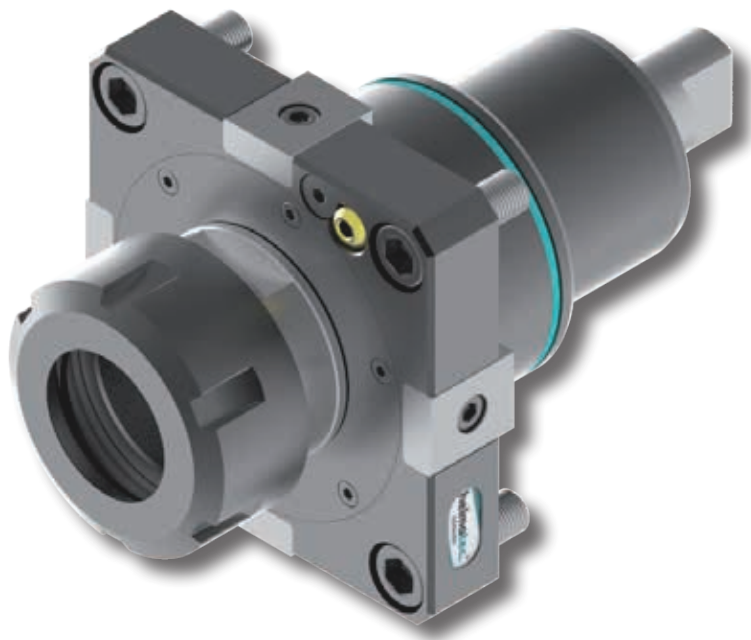

**Hwacheon**

BMT 85

Hi-TECH 850 MC



Das Katalog-Werk einschließlich aller seiner Teile ist urheberrechtlich geschützt. Jede Verwertung außerhalb der engen Grenzen des Urheberrechtsgesetzes ist ohne Zustimmung der Rechteinhaber unzulässig und strafbar. Das gilt insbesondere für Vervielfältigungen, Übersetzungen, Mikroverfilmungen und die Einspeicherung und Verarbeitung in elektronischen Systemen.

**heimatec® GmbH** behält sich Änderungen technischer Art jederzeit ohne Vorankündigung vor. Dies gilt insbesondere bei Anpassungen an neue oder geänderte internationale Normen oder bei Weiterentwicklungen unserer Produkte oder Herstellungsprozesse.

This catalogue, including all its parts, is protected by copyright. Each use outside the restricted limitations of the Copyright Act is inadmissible and liable to prosecution without the consent of heimatec. This is particularly valid for duplication, translation, microfilming and feeding and processing in electronic systems.

**heimatec® GmbH** reserves the right of technical changes everytime without advance notice, which is particularly valid for adaptations to new or changed international standards, or to developments of our products or manufacturing processes.

Hinweis zu den AGBs:  
Diese finden Sie in unserem Internetauftritt unter  
**heimatec.de**  
Home/Impressum/AGB

Terms and conditions:  
You will find them on our website  
**heimatec.com**  
Home/Imprint/Terms and Conditions



## angetriebene Werkzeuge driven tools



### Axial-Bohr- und Fräskopf axial drilling and milling head

$n_{max} = 4000 \text{ min}^{-1}$

8 010 77 007	ER 40 A u-tec	EK	1:1
8 010 77 009	ER 40 A u-tec	IK 25 bar	1:1
8 010 77 010	ER 40 A u-tec	IK 70 bar	1:1
8 010 78 000	ER 50	EK	1:1
8 010 78 001	ER 50	IK 25 bar	1:1
8 010 78 013	ER 50	IK 70 bar	1:1
8 010 78 002	easy quick HT 6	EK	1:1
8 010 78 005	easy quick HT 6	IK 25 bar	1:1
8 010 78 010	easy quick HT 6	IK 70 bar	1:1



### Axial-Fräskopf axial milling head

$n_{max} = 4000 \text{ min}^{-1}$

8 011 75 000	Kombidorn/universal arbor 22	EK 1:1
8 011 76 000	Kombidorn/universal arbor 27	EK 1:1



### Winkel-Bohr- und Fräskopf radial drilling and milling head

Mittenmaß / center distance  $H=85$

$n_{max} = 4000 \text{ min}^{-1}$

8 030 77 004	ER 40 A u-tec	EK	1:1
8 030 77 008	ER 40 A u-tec	IK 140 bar	1:1
8 030 78 000	ER 50	EK	1:1
8 030 78 001	ER 50	IK 140 bar	1:1
8 030 78 002	easy-quick HT 6	EK	1:1
8 030 78 004	easy-quick HT 6	IK 140 bar	1:1

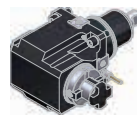

### Winkel-Fräskopf radial milling head

Mittenmaß / center distance  $H=85$

$n_{max} = 4000 \text{ min}^{-1}$

8 031 76 000	Kombidorn/universal arbor 27	EK 1:1
8 031 78 000	Kombidorn/universal arbor 40	EK 1:1



### Schwenkkopf universal head

$n_{max} = 4000 \text{ min}^{-1}$

8 040 75 000	ER 25 A u-tec	EK	1:1
8 040 75 003	ER 25 A u-tec	IK 140 bar	1:1

► Weitere Ausführungen auf Anfrage  
further versions on request

► Zubehör ZB...\*   
accessories ZB...\*

► easy-quick

► u-tec

### feste Werkzeuge static tool holders

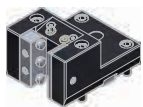

**Kombi-Drehstahlhalter**  
universal turning holder

8 224 26 000 Vierkant/square 32 EK  
8 224 26 004 Vierkant/square 1 1/4" EK



**Kombi-Plandrehhalter**  
combi facing holder

8 244 26 000 Vierkant/square 32 EK  
8 244 26 009 Vierkant/square 1 1/4" EK



**Bohrstangenhalter**  
boring bar holder

*Mittenmaß / center distance H=110*

8 240 29 013 ø50 IK/EK  
8 240 29 014 ø60 IK/EK  
8 240 29 038 ø2" IK/EK  
8 240 29 039 ø2 1/2" IK/EK

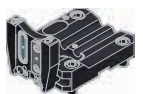

**Abstechhalter**  
cut-off holder

*höhenverstellbar / height adjustable*

8 320 23 023 SH 32 (1) IK 70 bar  
8 320 23 027 SH 32 (2) IK 70 bar



**Abstechhalter**  
cut-off holder

*höhenverstellbar / height adjustable*

**ph HORN ph**

8 320 29 004 HORN System 845 (1) IK 70 bar  
8 320 29 009 HORN System 845 (2) IK 70 bar



► Weitere Ausführungen auf Anfrage  
further versions on request

► Zubehör ZB...\*   
accessories ZB...\*

► easy-quick 

► u-tec 

- ▶ *easy-quick HT Schnellwechselsystem*  
*easy-quick HT fast change system*

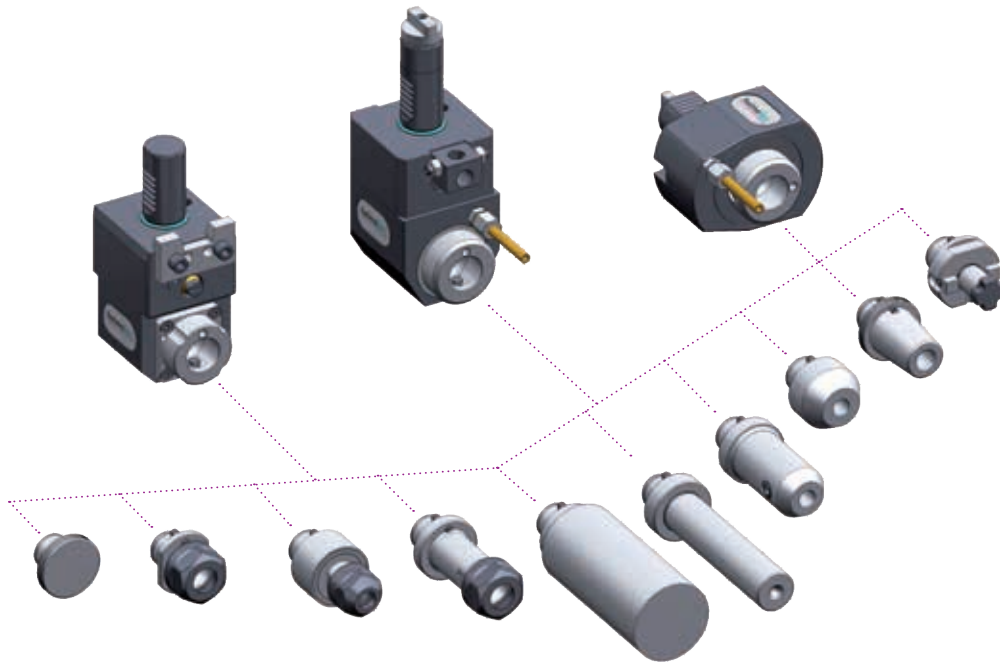

- ▶ Ausführungen siehe Katalog  
versions see catalogue

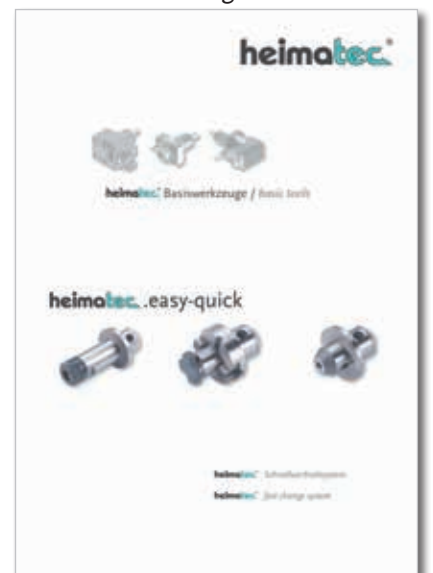

heimatec.de  
Produkte / easy-quick

heimatec.com  
products / easy-quick

► **u-tec® UT Wechselsystem**  
**u-tec® UT change system**

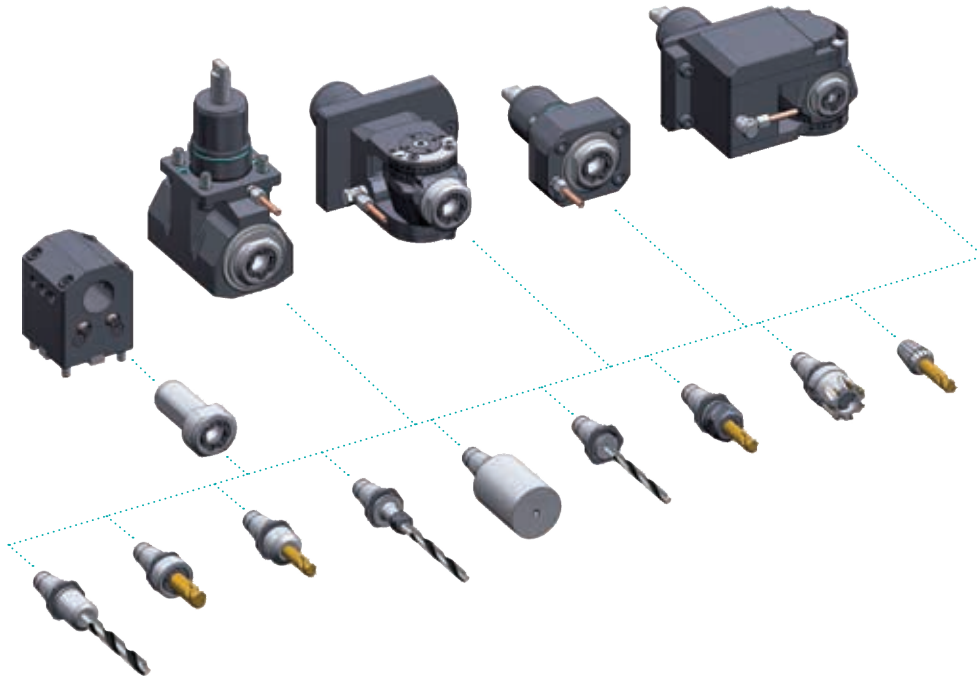

► Ausführungen siehe Katalog  
versions see catalogue



[heimatec.de](http://heimatec.de)  
Produkte / u-tec

[heimatec.com](http://heimatec.com)  
products / u-tec

► **Zubehör**  
**accessories**



► Ausführungen siehe Katalog  
versions see catalogue



heimatec.de  
Produkte / Zubehör  
heimatec.com  
products / accessories

# heimatec®

- heimatec®-Niederlassungen  
*heimatec® overseas branches*
- unsere weltweiten Vertretungen  
*global representations of heimatec®*



## Hauptsitz/headquarters

heimatec® GmbH  
Präzisionswerkzeuge  
Carl-Benz-Straße 4  
D- 77871 Renchen  
Postfach 11 36  
D- 77867 Renchen  
Tel.: +49 (78 43) 94 66 0  
Fax: +49 (78 43) 94 66 66  
heimatec.de  
info@heimatec.de

heimatec® Inc.  
USA  
usa.heimatec.com  
USA@heimatec.com  
  
heimatec®-Ost, JSC  
Russia  
ru.heimatec.com  
Russia@heimatec.com

heimatec® Ltd.  
Taiwan  
tw.heimatec.com  
Taiwan@heimatec.com  
  
heimatec®  
Singapore  
sg.heimatec.com  
Singapore@heimatec.com

heimatec® India Pvt Ltd.  
India  
in.heimatec.com  
India@heimatec.com  
  
heimatec®  
China  
cn.heimatec.com  
China@heimatec.com



**Werkzeugkatalog**  
tool catalogue

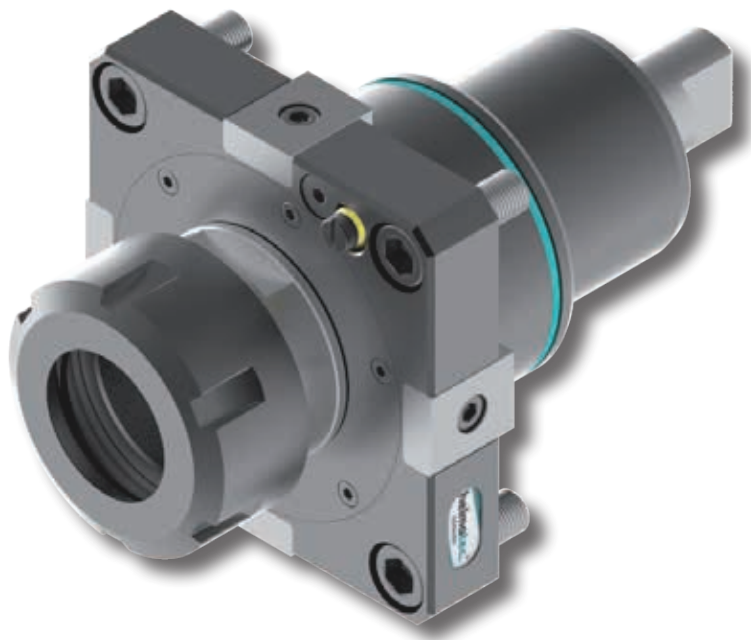

# Hwacheon

BMT 85

VT 950 M



Das Katalog-Werk einschließlich aller seiner Teile ist urheberrechtlich geschützt. Jede Verwertung außerhalb der engen Grenzen des Urheberrechtsgesetzes ist ohne Zustimmung der Rechteinhaber unzulässig und strafbar. Das gilt insbesondere für Vervielfältigungen, Übersetzungen, Mikroverfilmungen und die Einspeicherung und Verarbeitung in elektronischen Systemen.

**heimatec® GmbH** behält sich Änderungen technischer Art jederzeit ohne Vorankündigung vor. Dies gilt insbesondere bei Anpassungen an neue oder geänderte internationale Normen oder bei Weiterentwicklungen unserer Produkte oder Herstellungsprozesse.

This catalogue, including all its parts, is protected by copyright. Each use outside the restricted limitations of the Copyright Act is inadmissible and liable to prosecution without the consent of heimatec. This is particularly valid for duplication, translation, microfilming and feeding and processing in electronic systems.

**heimatec® GmbH** reserves the right of technical changes everytime without advance notice, which is particularly valid for adaptations to new or changed international standards, or to developments of our products or manufacturing processes.

Hinweis zu den AGBs:  
Diese finden Sie in unserem Internetauftritt unter  
**heimatec.de**  
Home/Impressum/AGB

Terms and conditions:  
You will find them on our website  
**heimatec.com**  
Home/Imprint/Terms and Conditions



## angetriebene Werkzeuge

driven tools



### Axial-Bohr- und Fräskopf

axial drilling and milling head

$n_{max} = 4000 \text{ min}^{-1}$

8 010 77 007	ER 40 A u-tec	EK	1:1
8 010 77 009	ER 40 A u-tec	IK 25 bar	1:1
8 010 77 010	ER 40 A u-tec	IK 70 bar	1:1
8 010 78 000	ER 50	EK	1:1
8 010 78 001	ER 50	IK 25 bar	1:1
8 010 78 013	ER 50	IK 70 bar	1:1
8 010 78 002	easy quick HT 6	EK	1:1
8 010 78 005	easy quick HT 6	IK 25 bar	1:1
8 010 78 010	easy quick HT 6	IK 70 bar	1:1



### Axial-Fräskopf

axial milling head

$n_{max} = 4000 \text{ min}^{-1}$

8 011 75 000	Kombidorn/universal arbor 22	EK 1:1
8 011 76 000	Kombidorn/universal arbor 27	EK 1:1



### Winkel-Bohr- und Fräskopf

radial drilling and milling head

Mittenmaß / center distance  $H=85$

$n_{max} = 4000 \text{ min}^{-1}$

8 030 77 004	ER 40 A u-tec	EK	1:1
8 030 77 008	ER 40 A u-tec	IK 140 bar	1:1
8 030 78 000	ER 50	EK	1:1
8 030 78 001	ER 50	IK 140 bar	1:1
8 030 78 002	easy-quick HT 6	EK	1:1
8 030 78 004	easy-quick HT 6	IK 140 bar	1:1



### Winkel-Fräskopf

radial milling head

Mittenmaß / center distance  $H=85$

$n_{max} = 4000 \text{ min}^{-1}$

8 031 76 000	Kombidorn/universal arbor 27	EK 1:1
8 031 78 000	Kombidorn/universal arbor 40	EK 1:1



### Schwenkkopf

universal head

$n_{max} = 4000 \text{ min}^{-1}$

8 040 75 000	ER 25 A u-tec	EK	1:1
8 040 75 003	ER 25 A u-tec	IK 140 bar	1:1

## festе Werkzeuge static tool holders

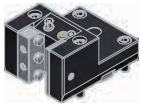

**Kombi-Drehstahlhalter**  
universal turning holder

8 224 26 000 Vierkant/square 32 EK  
8 224 26 004 Vierkant/square 1 1/4" EK



**Kombi-Plandrehhalter**  
combi facing holder

8 244 26 000 Vierkant/square 32 EK  
8 244 26 009 Vierkant/square 1 1/4" EK

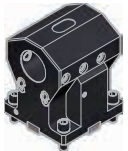

**Bohrstangenhalter**  
boring bar holder

Mittenmaß / center distance H=110

8 240 29 013  $\varnothing$ 50 IK/EK  
8 240 29 014  $\varnothing$ 60 IK/EK  
8 240 29 038  $\varnothing$ 2" IK/EK  
8 240 29 039  $\varnothing$ 2 1/2" IK/EK

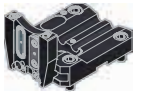

**Abstechhalter**  
cut-off holder

höhenverstellbar / height adjustable

8 320 23 023 SH 32 (1) IK 70 bar  
8 320 23 027 SH 32 (2) IK 70 bar



(1) (2)



**Abstechhalter**  
cut-off holder

höhenverstellbar / height adjustable





8 320 29 004 HORN System 845 (1) IK 70 bar  
8 320 29 009 HORN System 845 (2) IK 70 bar



(1) (2)

► Weitere Ausführungen auf Anfrage  
further versions on request

► Zubehör ZB...\*   
accessories ZB...\*

► easy-quick 

► u-tec 

- ▶ *easy-quick HT Schnellwechselsystem*  
*easy-quick HT fast change system*

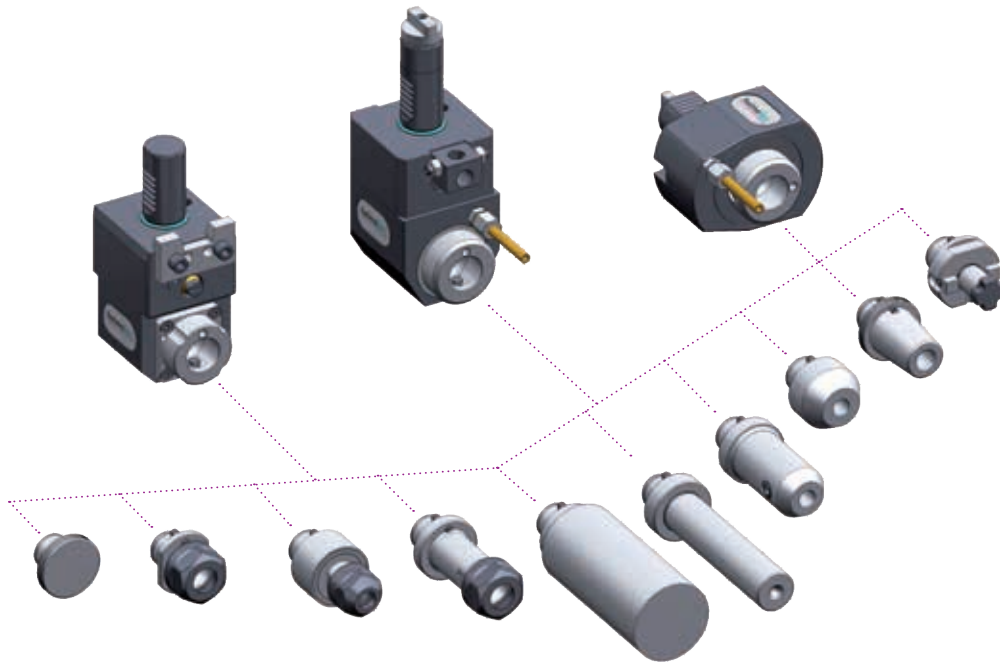

- ▶ Ausführungen siehe Katalog  
versions see catalogue

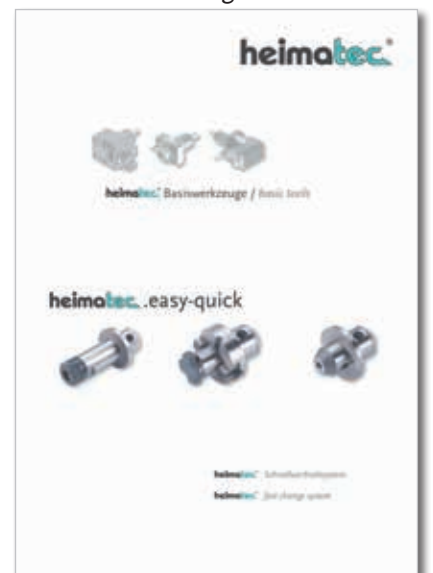

heimatec.de  
Produkte / easy-quick

heimatec.com  
products / easy-quick

► u-tec® UT Wechselsystem  
u-tec® UT change system

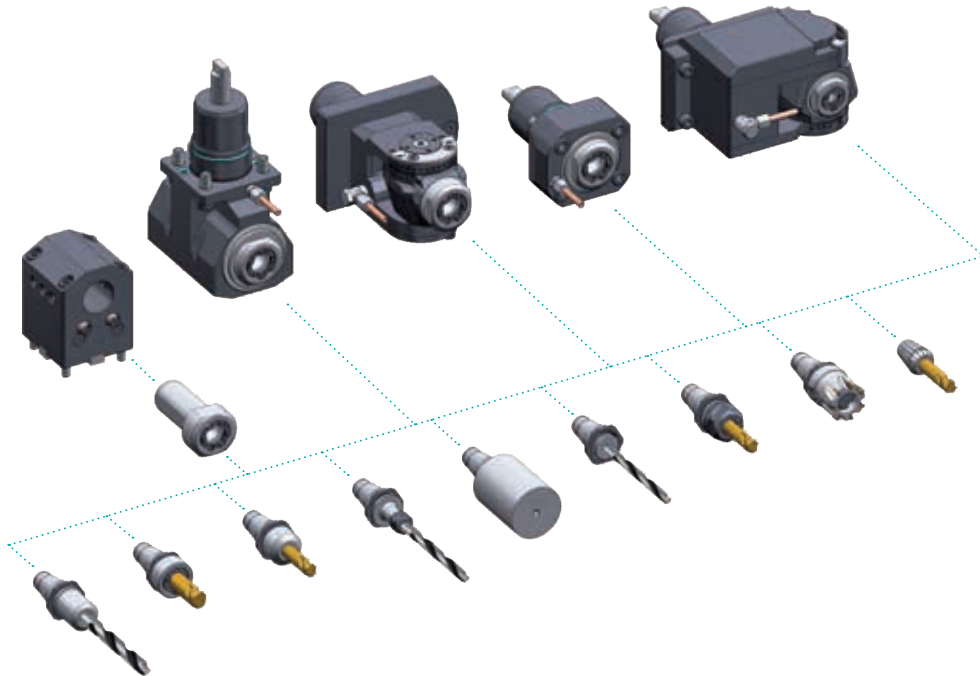

► Ausführungen siehe Katalog  
versions see catalogue



heimatec.de  
Produkte / u-tec

heimatec.com  
products / u-tec

► **Zubehör**  
**accessories**



► Ausführungen siehe Katalog  
versions see catalogue



heimatec.de  
Produkte / Zubehör  
heimatec.com  
products / accessories

# heimatec®

- heimatec®-Niederlassungen  
*heimatec® overseas branches*
- unsere weltweiten Vertretungen  
*global representations of heimatec®*



## Hauptsitz/headquarters

heimatec® GmbH  
Präzisionswerkzeuge  
Carl-Benz-Straße 4  
D- 77871 Renchen  
Postfach 11 36  
D- 77867 Renchen  
Tel.: +49 (78 43) 94 66 0  
Fax: +49 (78 43) 94 66 66  
heimatec.de  
info@heimatec.de

heimatec® Inc.  
USA  
usa.heimatec.com  
USA@heimatec.com  
  
heimatec®-Ost, JSC  
Russia  
ru.heimatec.com  
Russia@heimatec.com

heimatec® Ltd.  
Taiwan  
tw.heimatec.com  
Taiwan@heimatec.com  
  
heimatec®  
Singapore  
sg.heimatec.com  
Singapore@heimatec.com

heimatec® India Pvt Ltd.  
India  
in.heimatec.com  
India@heimatec.com  
  
heimatec®  
China  
cn.heimatec.com  
China@heimatec.com



**Werkzeugkatalog**  
tool catalogue

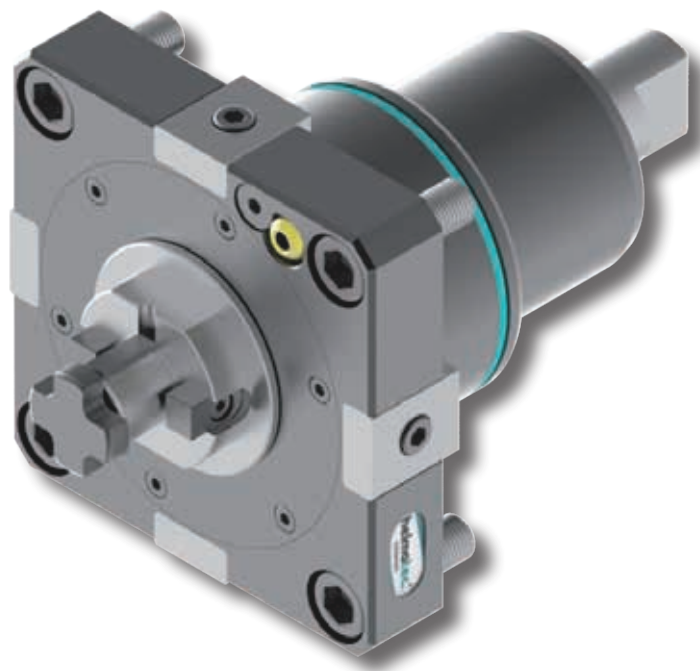

# Hwacheon

BMT 85

VT 1150 M



Das Katalog-Werk einschließlich aller seiner Teile ist urheberrechtlich geschützt. Jede Verwertung außerhalb der engen Grenzen des Urheberrechtsgesetzes ist ohne Zustimmung der Rechteinhaber unzulässig und strafbar. Das gilt insbesondere für Vervielfältigungen, Übersetzungen, Mikroverfilmungen und die Einspeicherung und Verarbeitung in elektronischen Systemen.

**heimatec® GmbH** behält sich Änderungen technischer Art jederzeit ohne Vorankündigung vor. Dies gilt insbesondere bei Anpassungen an neue oder geänderte internationale Normen oder bei Weiterentwicklungen unserer Produkte oder Herstellungsprozesse.

This catalogue, including all its parts, is protected by copyright. Each use outside the restricted limitations of the Copyright Act is inadmissible and liable to prosecution without the consent of heimatec. This is particularly valid for duplication, translation, microfilming and feeding and processing in electronic systems.

**heimatec® GmbH** reserves the right of technical changes everytime without advance notice, which is particularly valid for adaptations to new or changed international standards, or to developments of our products or manufacturing processes.

Hinweis zu den AGBs:  
Diese finden Sie in unserem Internetauftritt unter  
**heimatec.de**  
Home/Impressum/AGB

Terms and conditions:  
You will find them on our website  
**heimatec.com**  
Home/Imprint/Terms and Conditions



## angetriebene Werkzeuge

driven tools



### Axial-Bohr- und Fräskopf

axial drilling and milling head

$n_{max} = 4000 \text{ min}^{-1}$

8 010 77 007	ER 40 A u-tec	EK	1:1
8 010 77 009	ER 40 A u-tec	IK 25 bar	1:1
8 010 77 010	ER 40 A u-tec	IK 70 bar	1:1
8 010 78 000	ER 50	EK	1:1
8 010 78 001	ER 50	IK 25 bar	1:1
8 010 78 013	ER 50	IK 70 bar	1:1
8 010 78 002	<i>easy quick</i> HT 6	EK	1:1
8 010 78 005	<i>easy quick</i> HT 6	IK 25 bar	1:1
8 010 78 010	<i>easy quick</i> HT 6	IK 70 bar	1:1



### Axial-Fräskopf

axial milling head

$n_{max} = 4000 \text{ min}^{-1}$

8 011 75 000	Kombidorn/universal arbor 22	EK 1:1
8 011 76 000	Kombidorn/universal arbor 27	EK 1:1



### Winkel-Bohr- und Fräskopf

radial drilling and milling head

Mittenmaß / center distance  $H=85$

$n_{max} = 4000 \text{ min}^{-1}$

8 030 77 004	ER 40 A u-tec	EK	1:1
8 030 77 008	ER 40 A u-tec	IK 140 bar	1:1
8 030 78 000	ER 50	EK	1:1
8 030 78 001	ER 50	IK 140 bar	1:1
8 030 78 002	<i>easy-quick</i> HT 6	EK	1:1
8 030 78 004	<i>easy-quick</i> HT 6	IK 140 bar	1:1

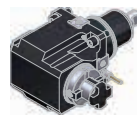

### Winkel-Fräskopf

radial milling head

Mittenmaß / center distance  $H=85$

$n_{max} = 4000 \text{ min}^{-1}$

8 031 76 000	Kombidorn/universal arbor 27	EK 1:1
8 031 78 000	Kombidorn/universal arbor 40	EK 1:1



### Schwenkkopf

universal head

$n_{max} = 4000 \text{ min}^{-1}$

8 040 75 000	ER 25 A u-tec	EK	1:1
8 040 75 003	ER 25 A u-tec	IK 140 bar	1:1

## feste Werkzeuge static tool holders

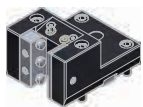

**Kombi-Drehstahlhalter**  
universal turning holder

8 224 26 000 Vierkant/square 32 EK  
8 224 26 004 Vierkant/square 1 1/4" EK



**Kombi-Plandrehhalter**  
combi facing holder

8 244 26 000 Vierkant/square 32 EK  
8 244 26 009 Vierkant/square 1 1/4" EK



**Bohrstangenhalter**  
boring bar holder

Mittenmaß / center distance H=110

8 240 29 013 ø50 IK/EK  
8 240 29 014 ø60 IK/EK  
8 240 29 038 ø2" IK/EK  
8 240 29 039 ø2 1/2" IK/EK

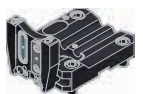

**Abstechhalter**  
cut-off holder

höhenverstellbar / height adjustable

8 320 23 023 SH 32 (1) IK 70 bar  
8 320 23 027 SH 32 (2) IK 70 bar



(1) (2)



**Abstechhalter**  
cut-off holder

**ph HORN ph**

höhenverstellbar / height adjustable

8 320 29 004 HORN System 845 (1) IK 70 bar  
8 320 29 009 HORN System 845 (2) IK 70 bar



(1) (2)

► Weitere Ausführungen auf Anfrage  
further versions on request

► Zubehör ZB...\*   
accessories ZB...\*

► easy-quick 

► u-tec 

- ▶ *easy-quick HT Schnellwechselsystem*  
*easy-quick HT fast change system*

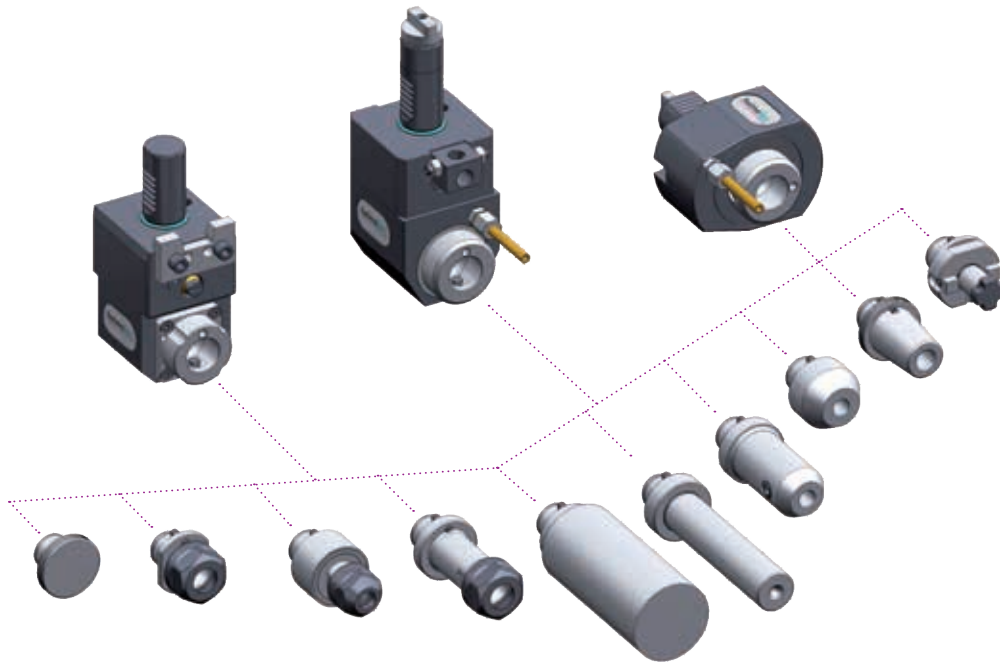

- ▶ Ausführungen siehe Katalog  
versions see catalogue

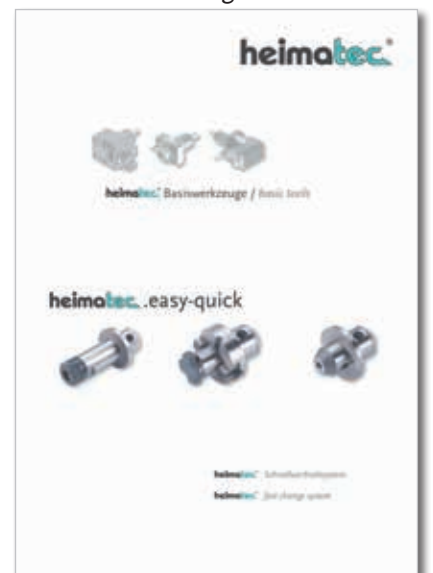

heimatec.de  
Produkte / easy-quick

heimatec.com  
products / easy-quick

► **u-tec® UT Wechselsystem**  
**u-tec® UT change system**

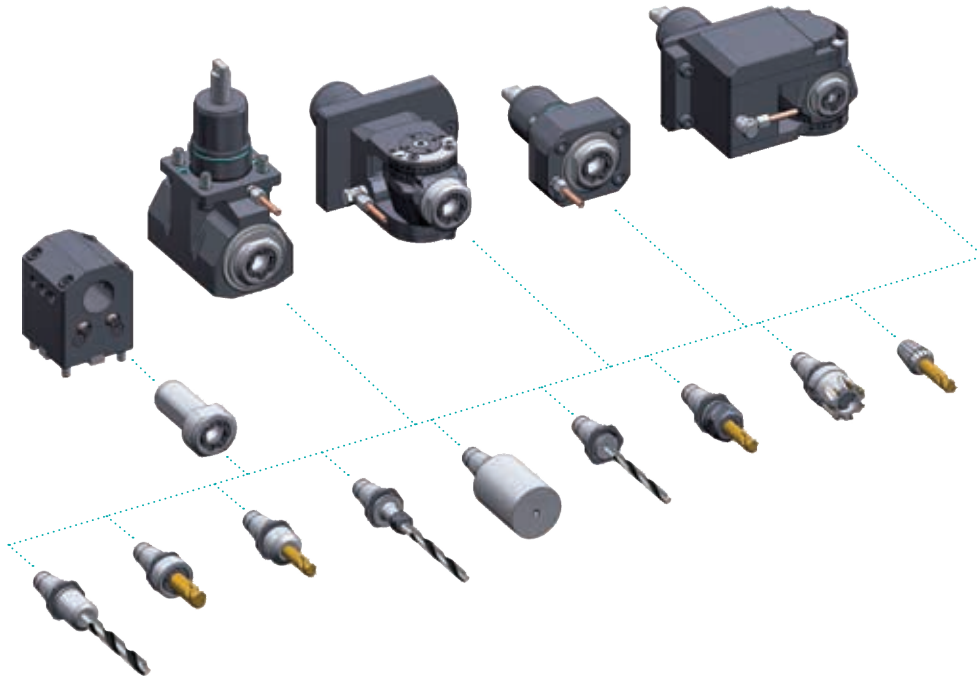

► Ausführungen siehe Katalog  
versions see catalogue



[heimatec.de](http://heimatec.de)  
Produkte / u-tec

[heimatec.com](http://heimatec.com)  
products / u-tec

► **Zubehör**  
**accessories**



► Ausführungen siehe Katalog  
versions see catalogue



heimatec.de  
Produkte / Zubehör  
heimatec.com  
products / accessories

# heimatec®

- heimatec®-Niederlassungen  
*heimatec® overseas branches*
- unsere weltweiten Vertretungen  
*global representations of heimatec®*

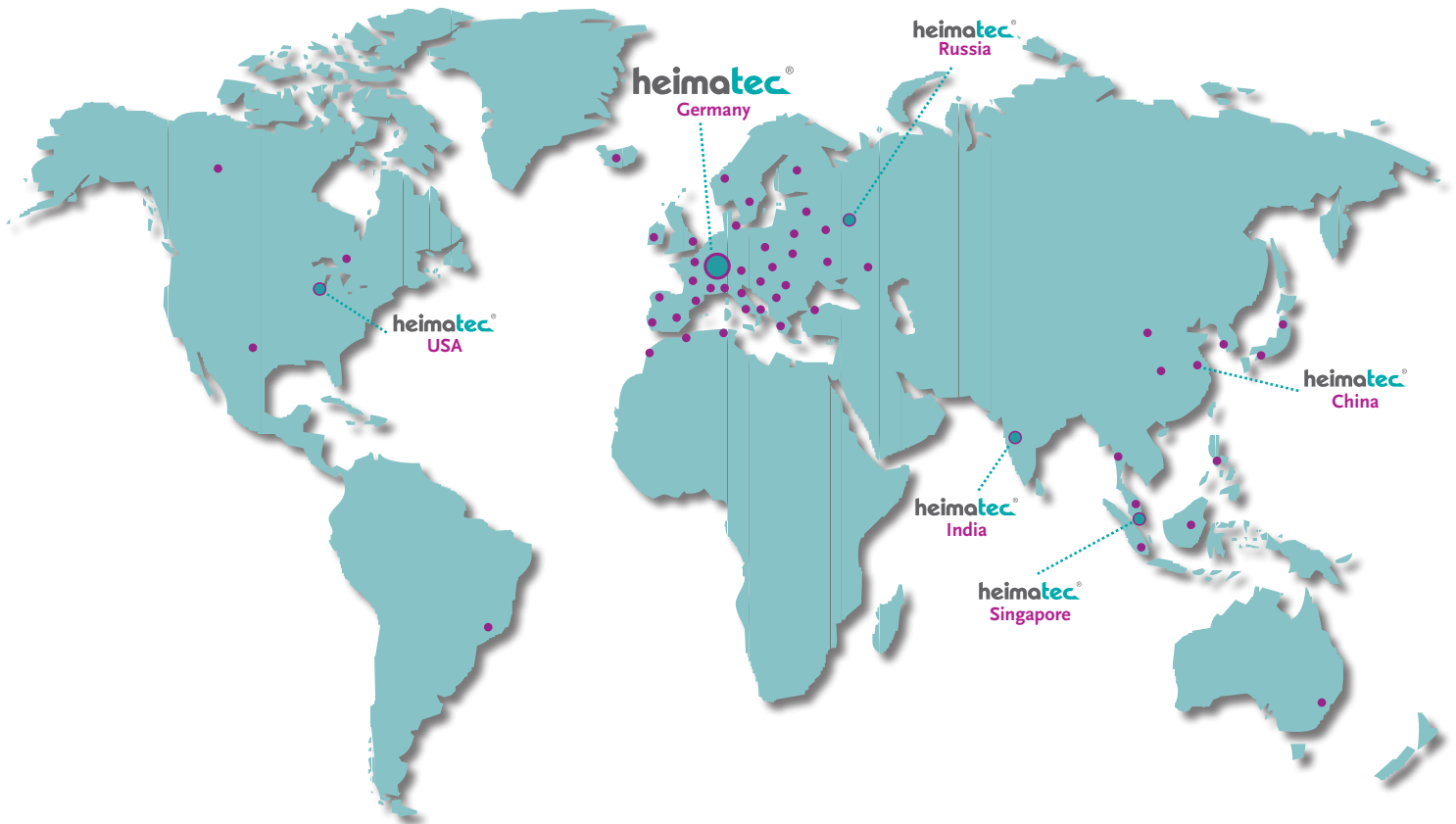

## Hauptsitz/headquarters

heimatec® GmbH  
Präzisionswerkzeuge  
Carl-Benz-Straße 4  
D- 77871 Renchen  
Postfach 11 36  
D- 77867 Renchen  
Tel.: +49 (78 43) 94 66 0  
Fax: +49 (78 43) 94 66 66  
heimatec.de  
info@heimatec.de

heimatec® Inc.  
USA  
usa.heimatec.com  
USA@heimatec.com  
  
heimatec®-Ost, JSC  
Russia  
ru.heimatec.com  
Russia@heimatec.com

heimatec® Ltd.  
Taiwan  
tw.heimatec.com  
Taiwan@heimatec.com  
  
heimatec®  
Singapore  
sg.heimatec.com  
Singapore@heimatec.com

heimatec® India Pvt Ltd.  
India  
in.heimatec.com  
India@heimatec.com  
  
heimatec®  
China  
cn.heimatec.com  
China@heimatec.com