

Werkzeugkatalog

tool catalogue

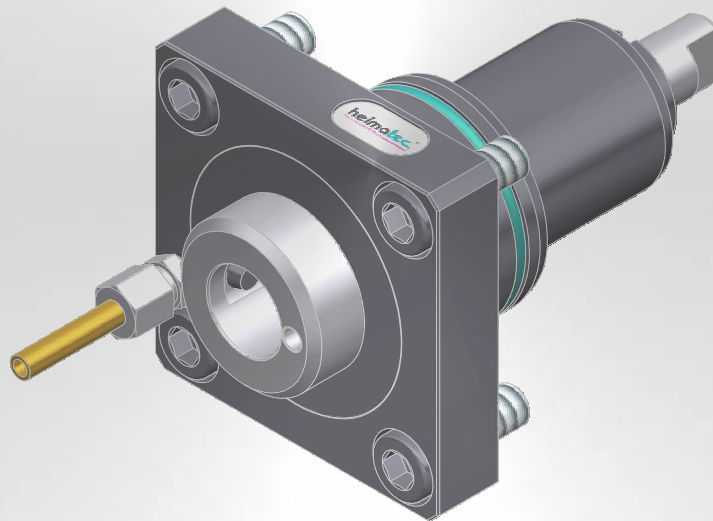

HYUNDAI WIA

L 230 LMSA



Hinweis zu den AGBs:

Diese finden Sie in unserem Internetauftritt unter

www.heimatec.de

Home/Impressum/AGB

Terms and conditions:

You will find them on our website

www.heimatec.com

Home/Imprint/Terms and Conditions

Das Katalog-Werk einschließlich aller seiner Teile ist urheberrechtlich geschützt. Jede Verwertung außerhalb der engen Grenzen des Urheberrechtsgesetzes ist ohne Zustimmung der Rechteeinhaber unzulässig und strafbar. Das gilt insbesondere für Vervielfältigungen, Übersetzungen, Mikroverfilmungen und die Einspeicherung und Verarbeitung in elektronischen Systemen.

heimatec® GmbH behält sich Änderungen technischer Art jederzeit ohne Vorankündigung vor. Dies gilt insbesondere bei Anpassungen an neue oder geänderte internationale Normen oder bei Weiterentwicklungen unserer Produkte oder Herstellungsprozesse.

This catalogue, including all its parts, is protected by copyright. Each use outside the restricted limitations of the Copyright Act is inadmissible and liable to prosecution without the consent of heimatec. This is particularly valid for duplication, translation, microfilming and feeding and processing in electronic systems.

heimatec® GmbH reserves the right of technical changes everytime without advance notice, which is particularly valid for adaptations to new or changed international standards, or to developments of our products or manufacturing processes.

angetriebene Werkzeuge
driven tools



Axial-Bohr- und Fräskopf
axial drilling and milling head

$n_{max} = 6000 \text{ min}^{-1}$

8 010 55 039	ER 25 AX u-tec	EK	1:1
8 010 55 038	ER 25 AX u-tec	IK 25 bar	1:1
8 010 55 057	ER 25 AX u-tec	IK 70 bar	1:1
8 010 56 039	ER 32 AX u-tec	EK	1:1
8 010 56 040	ER 32 AX u-tec	IK 25 bar	1:1
8 010 56 089	ER 32 AX u-tec	IK 70 bar	1:1
8 010 56 085	easy-quick HT 4	EK	1:1
8 010 56 086	easy-quick HT 4	IK 25 bar	1:1
8 010 56 087	easy-quick HT 4	IK 70 bar	1:1



Axial-Bohr- und Fräskopf kurze Ausführung
axial drilling and milling head short version

$n_{max} = 6000 \text{ min}^{-1}$

8 010 56 034	easy-quick HT 4	EK	1:1
8 010 56 035	easy-quick HT 4	IK 25 bar	1:1



Axial-Bohr- und Fräskopf
axial drilling and milling head

$n_{max} = 24000 \text{ min}^{-1}$

8 013 54 008	ER 16 AX u-tec	EK	1:4
8 013 54 009	ER 16 AX u-tec	IK 70 bar	1:4



Axial-Bohr- und Fräskopf
axial drilling and milling head

$n_{max} = 6000 \text{ min}^{-1}$

8 011 55 012	Kombidom/universal arbor 22	EK	1:1
8 011 55 017	Kombidom/universal arbor 1"	EK	1:1



Axial-Bohr- und Fräskopf
axial drilling and milling head

Achsversatz / offset A=42

8 019 54 022	ER 20 AX u-tec	EK	1:1
8 019 54 023	ER 20 AX u-tec	IK 140 bar	1:1
$n_{max} = 6000 \text{ min}^{-1}$			
8 019 54 024	ER 20 AX u-tec	EK	1:2
8 019 54 025	ER 20 AX u-tec	IK 140 bar	1:2
$n_{max} = 12000 \text{ min}^{-1}$			
8 019 54 026	ER 20 AX u-tec	EK	1:3
8 019 54 027	ER 20 AX u-tec	IK 140 bar	1:3
$n_{max} = 18000 \text{ min}^{-1}$			

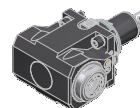
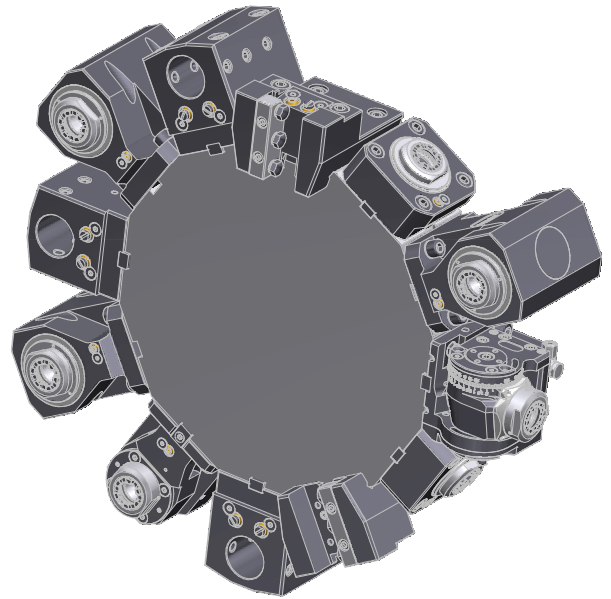

Winkel-Bohr- und Fräskopf
radial drilling and milling head

Mittenmaß / center distance H=85
 $n_{max} = 6000 \text{ min}^{-1}$

8 030 55 093	ER 25 AX u-tec	EK	1:1
8 030 55 098	ER 25 AX u-tec	IK 140 bar	1:1
8 030 56 099	easy-quick HT 4	EK	1:1
8 030 56 150	easy-quick HT 4	IK 140 bar	1:1

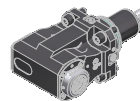

Axial-Bohr- und Fräskopf
axial drilling and milling head

Mittenmaß / center distance H=80

8 030 55 068	ER 25 AX u-tec	EK	1:2
8 030 55 066	ER 25 AX u-tec	IK 140 bar	1:2
$n_{max} = 12000 \text{ min}^{-1}$			
8 030 55 069	ER 25 AX u-tec	EK	1:3
8 030 55 067	ER 25 AX u-tec	IK 140 bar	1:3
$n_{max} = 18000 \text{ min}^{-1}$			



Winkel-Bohr- und Fräskopf
radial drilling and milling head

Mittenmaß / center distance H=85
 $n_{max} = 24000 \text{ min}^{-1}$

8 030 54 057	ER 16 AX u-tec	EK	1:4
8 030 54 058	ER 16 AX u-tec	IK 70 bar	1:4

► Weitere Ausführungen auf Anfrage
further versions on request

► Zubehör ZB...*
accessories ZB...*

► easy-quick



► u-tec



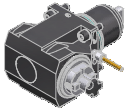

Winkel-Bohr- und Fräskopf
radial drilling and milling head

Mittenmaß / center distance $H=85$
 $n_{max} = 6000 \text{ min}^{-1}$

8 031 55 025	Kombidorn/universal arbor 22	EK	1:1
8 031 55 026	Kombidorn/universal arbor 1"	EK	1:1

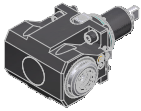

Winkel-Bohr- und Fräskopf
radial drilling and milling head

Mittenmaß / center distance $H=85$
doppelspindlig / double spindle
 $n_{max} = 6000 \text{ min}^{-1}$

8 039 55 026	ER 25 AX u-tec	EK	1:1
8 039 56 028	easy-quick HT 4	EK	1:1



Schwenkkopf
universal head

Mittenmaß / center distance $H=50$
Achsversatz / offset $A=35$

8 043 55 005	ER 25 AX u-tec	EK	1:1
8 043 55 009	ER 25 AX u-tec	IK 25 bar	1:1
$n_{max} = 6000 \text{ min}^{-1}$			
8 043 54 013	ER 16 AX u-tec	EK	1:2
8 043 54 014	ER 16 AX u-tec	IK 25 bar	1:2
$n_{max} = 12000 \text{ min}^{-1}$			



Winkel-Scheibenfräserkopf **±30° drehbar**
radial disk mill head **±30° turnable**

Mittenmaß / center distance $H=78$
auf 0° absteckbar / 0° can be pinned
kein Kühlmittel / no coolant
 $n_{max} = 4000 \text{ min}^{-1}$

8 037 54 013	Ø 16	2:1
8 037 54 014	Ø 5/8"	2:1



► Weitere Ausführungen auf Anfrage
further versions on request

► Zubehör ZB...* 
accessories ZB...*

► easy-quick 

► u-tec 

feste Werkzeuge
static tool holders

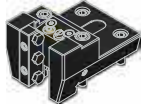

Kombi-Drehstahlhalter
universal turning holder

8 224 05 003	Vierkant/square 25	EK
8 224 05 005	Vierkant/square 1"	EK

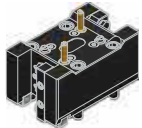

Kombi-Doppel-Drehstahlhalter
combi double turning holder

8 251 05 001	Vierkant/square 25	EK
8 251 05 003	Vierkant/square 1"	EK



Kombi-Plandrehhalter
combi facing holder

8 244 05 003	Vierkant/square 25	EK
8 244 05 006	Vierkant/square 1"	EK



Bohrstangenhalter
boring bar holder

Mittenmaß / center distance H=95

8 240 08 026	ø32	IK/EK
8 240 08 028	ø40	IK/EK
8 240 08 027	ø1 1/4"	IK/EK
8 240 08 029	ø1 1/2"	IK/EK

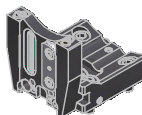

Abstechhalter
cut-off holder

höhenverstellbar / height adjustable

8 320 03 008	SH 32	IK 70 bar
--------------	--------------	-----------

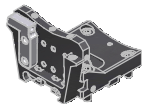

Abstechhalter
cut-off holder

höhenverstellbar / height adjustable



8 320 09 001	HORN System 845	IK 70 bar
--------------	------------------------	-----------

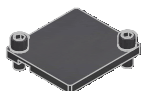

Abdeckblech
cover plate

8 200 52 001

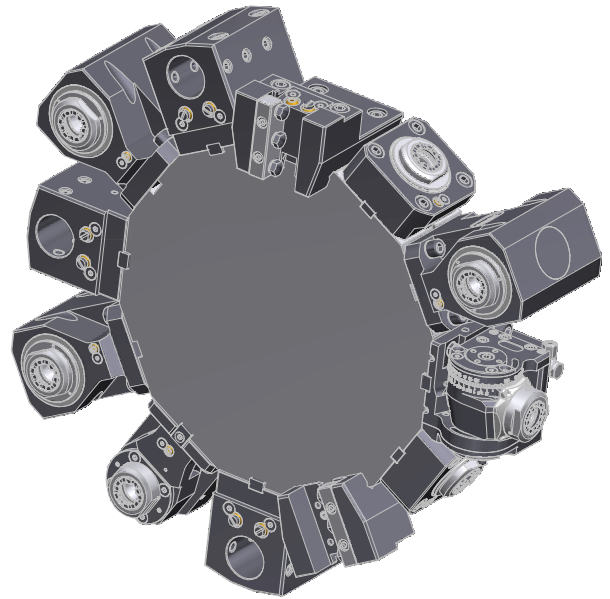

HYUNDAI WIA L 230 LMSA

▶ Weitere Ausführungen auf Anfrage
further versions on request

▶ Zubehör **ZB...***
accessories **ZB...*** 

▶ **easy-quick** 

▶ **u-tec** 

► **easy-quick HT Schnellwechselsystem**
easy-quick HT fast change system

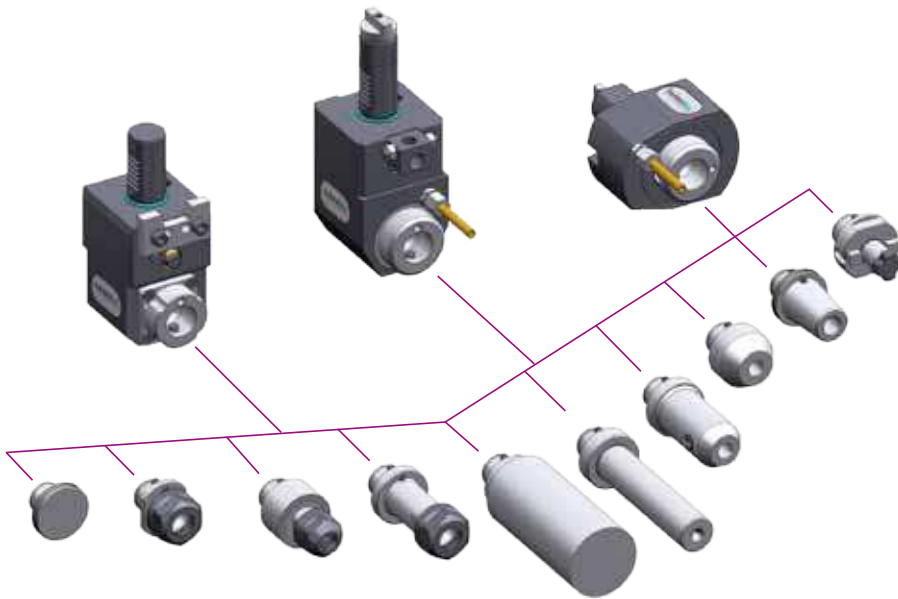

DAS Schnellwechselsystem von heimatec
für angetriebene und feste Werkzeuge

*THE fast change system of heimatec
for driven and static tools*

www.heimatec.de
Produkte / easy-quick

www.heimatec.com
products / easy-quick

► Ausführungen siehe Katalog
versions see catalogue



► **u-tec[®] UT Wechselsystem**
u-tec[®] UT change system

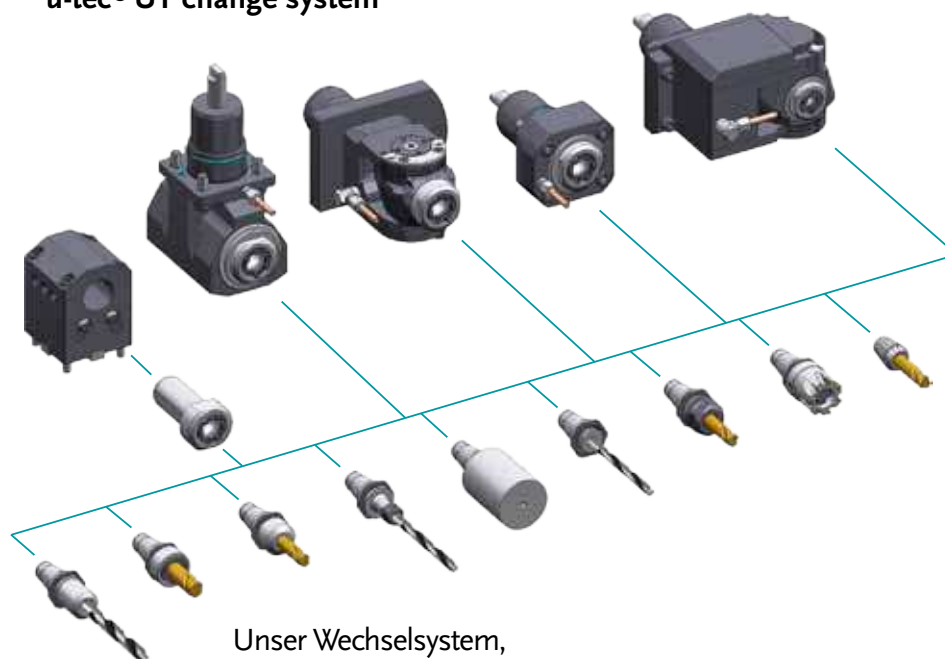

Unser Wechselsystem,
das ALLES möglich macht

Our change system,
that makes EVERYTHING possible

www.heimatec.de
Produkte / u-tec

www.heimatec.com
products / u-tec

► Ausführungen siehe Katalog
versions see catalogue



heimatec®

- heimatec®-Niederlassungen
heimatec® overseas branches
- unsere weltweiten Vertretungen
global representations of heimatec®

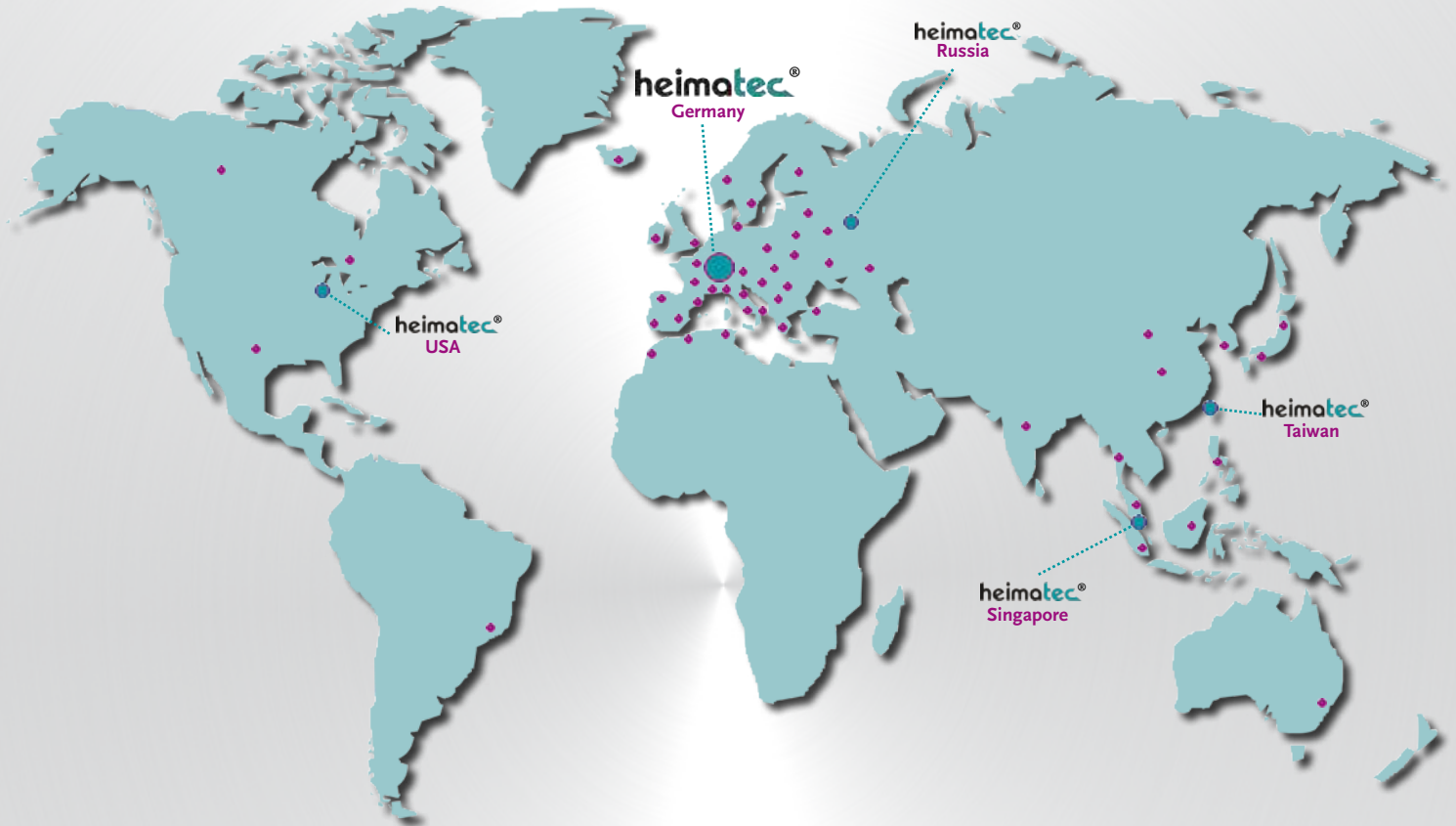

Hauptsitz/headquarters

heimatec® GmbH
Präzisionswerkzeuge
Carl-Benz-Straße 4
D- 77871 Renchen
Postfach 11 36
D- 77867 Renchen
Tel.: +49 (78 43) 94 66 0
Fax: +49 (78 43) 94 66 66
heimatec.de
info@heimatec.de

heimatec® Inc.
USA
usa.heimatec.com
USA@heimatec.com

heimatec®-Ost, JSC
Russia
ru.heimatec.com
Russia@heimatec.com

heimatec® Ltd.
Taiwan
tw.heimatec.com
Taiwan@heimatec.com

heimatec®
Singapore
sg.heimatec.com
Singapore@heimatec.com



Werkzeugkatalog

tool catalogue

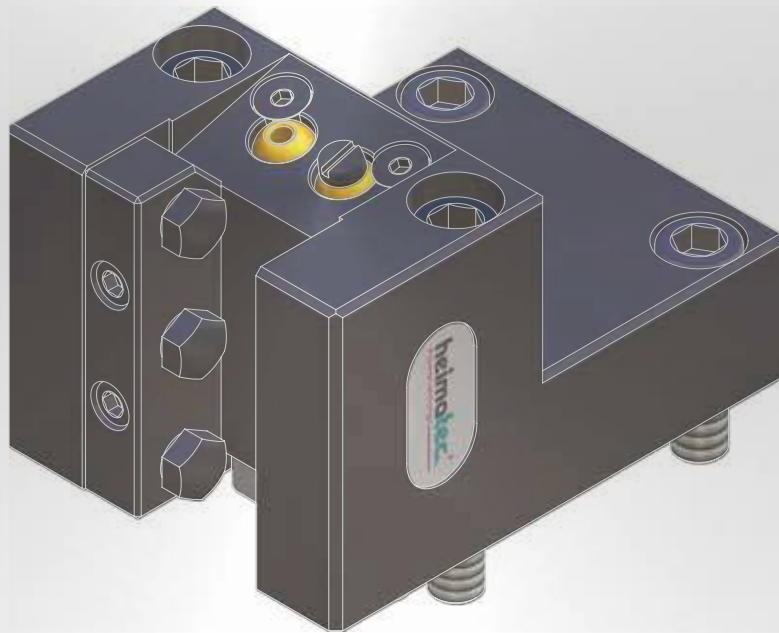

HYUNDAI WIA

L 300 MA / LMA

L 300 MC / LMC



Hinweis zu den AGBs:

Diese finden Sie in unserem Internetauftritt unter

www.heimatec.de

Home/Impressum/AGB

Terms and conditions:

You will find them on our website

www.heimatec.com

Home/Imprint/Terms and Conditions

Das Katalog-Werk einschließlich aller seiner Teile ist urheberrechtlich geschützt. Jede Verwertung außerhalb der engen Grenzen des Urheberrechtsgesetzes ist ohne Zustimmung der Rechteeinhaber unzulässig und strafbar. Das gilt insbesondere für Vervielfältigungen, Übersetzungen, Mikroverfilmungen und die Einspeicherung und Verarbeitung in elektronischen Systemen.

heimatec® GmbH behält sich Änderungen technischer Art jederzeit ohne Vorankündigung vor. Dies gilt insbesondere bei Anpassungen an neue oder geänderte internationale Normen oder bei Weiterentwicklungen unserer Produkte oder Herstellungsprozesse.

This catalogue, including all its parts, is protected by copyright. Each use outside the restricted limitations of the Copyright Act is inadmissible and liable to prosecution without the consent of heimatec. This is particularly valid for duplication, translation, microfilming and feeding and processing in electronic systems.

heimatec® GmbH reserves the right of technical changes everytime without advance notice, which is particularly valid for adaptations to new or changed international standards, or to developments of our products or manufacturing processes.

angetriebene Werkzeuge

driven tools



Axial-Bohr- und Fräskopf

axial drilling and milling head

$n_{max} = 6000 \text{ min}^{-1}$

8 010 66 079	ER 32 AX u-tec	EK	1:1
8 010 66 081	ER 32 AX u-tec	IK 25 bar	1:1
8 010 66 046	ER 32 AX u-tec	IK 70 bar	1:1
8 010 67 025	easy-quick HT 5	EK	1:1
8 010 67 026	easy-quick HT 5	IK 25 bar	1:1
8 010 67 060	easy-quick HT 5	IK 70 bar	1:1



Axial-Bohr- und Fräskopf

axial drilling and milling head

$n_{max} = 24000 \text{ min}^{-1}$

8 013 64 008	ER 16 AX u-tec	EK	1:4
8 013 64 009	ER 16 AX u-tec	IK 70 bar	1:4



Axial-Bohr- und Fräskopf

axial drilling and milling head

$n_{max} = 6000 \text{ min}^{-1}$

8 011 65 014	Kombidorn/universal arbor 22	EK	1:1
8 011 65 011	Kombidorn/universal arbor 1"	EK	1:1



Axial-Bohr- und Fräskopf

axial drilling and milling head

Achsversatz / offset $A=50$

8 019 65 021	ER 25 AX u-tec	EK	1:1
8 019 65 022	ER 25 AX u-tec	IK 140 bar	1:1
$n_{max} = 6000 \text{ min}^{-1}$			
8 019 65 004	ER 25 AX u-tec	EK	1:2
8 019 65 027	ER 25 AX u-tec	IK 140 bar	1:2
$n_{max} = 12000 \text{ min}^{-1}$			
8 019 65 023	ER 25 AX u-tec	EK	2:1
8 019 65 024	ER 25 AX u-tec	IK 140 bar	2:1
$n_{max} = 3000 \text{ min}^{-1}$			
8 019 65 025	ER 25 AX u-tec	EK	1:3
8 019 65 026	ER 25 AX u-tec	IK 140 bar	1:3
$n_{max} = 15000 \text{ min}^{-1}$			

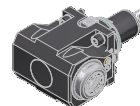
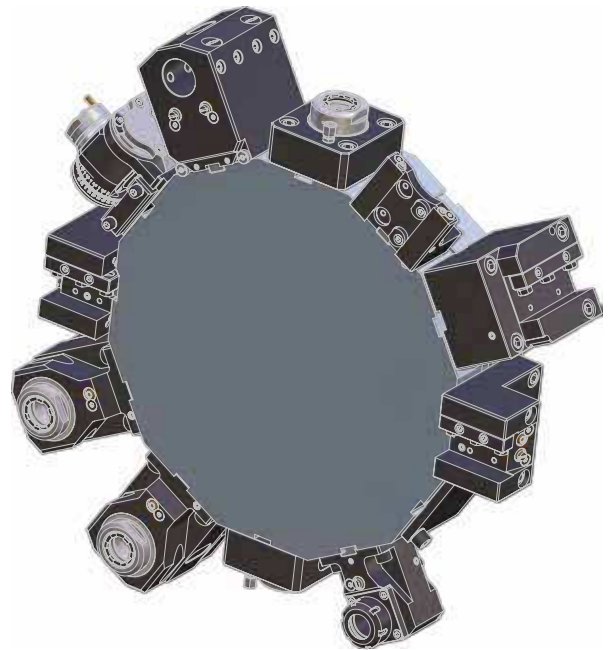

Winkel-Bohr- und Fräskopf

radial drilling and milling head

Mittenmaß / center distance $H=72$

$n_{max} = 6000 \text{ min}^{-1}$

8 030 66 097	ER 32 AX u-tec	EK	1:1
8 030 66 098	ER 32 AX u-tec	IK 140 bar	1:1
8 030 67 025	easy-quick HT 5	EK	1:1
8 030 67 075	easy-quick HT 5	IK 140 bar	1:1

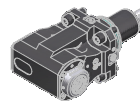

Axial-Bohr- und Fräskopf

axial drilling and milling head

Mittenmaß / center distance $H=95$

8 030 65 055	ER 25 AX u-tec	EK	1:2
8 030 65 063	ER 25 AX u-tec	IK 140 bar	1:2
$n_{max} = 12000 \text{ min}^{-1}$			
8 030 65 064	ER 25 AX u-tec	EK	1:3
8 030 65 065	ER 25 AX u-tec	IK 140 bar	1:3
$n_{max} = 18000 \text{ min}^{-1}$			



Winkel-Bohr- und Fräskopf

radial drilling and milling head

Mittenmaß / center distance $H=72$

$n_{max} = 24000 \text{ min}^{-1}$

8 030 64 021	ER 16 AX u-tec	EK	1:4
8 030 64 023	ER 16 AX u-tec	IK 140 bar	1:4

► Weitere Ausführungen auf Anfrage
further versions on request

► Zubehör **ZB...***
accessories **ZB...***

► easy-quick



► u-tec

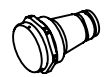

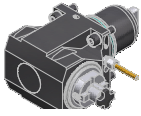

Winkel-Bohr- und Fräskopf radial drilling and milling head

Mittenmaß / center distance $H=72$
 $n_{max} = 6000 \text{ min}^{-1}$

8 031 65 015	Kombidorn/universal arbor 22	EK	1:1
8 031 65 010	Kombidorn/universal arbor 1"	EK	1:1

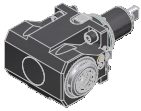

Winkel-Bohr- und Fräskopf radial drilling and milling head

Mittenmaß / center distance $H=72$
doppelspindlig / double spindle
 $n_{max} = 6000 \text{ min}^{-1}$

8 039 66 025	ER 32 AX u-tec	EK	1:1
8 039 67 009	easy-quick HT 5	EK	1:1



Schwenkkopf universal head

Mittenmaß / center distance $H=69$
Achsversatz / offset $A=60$

8 043 65 000	ER 25 AX u-tec	EK	1:1
8 043 65 004	ER 25 AX u-tec	IK 140 bar	1:1
$n_{max} = 6000 \text{ min}^{-1}$			
8 043 64 008	ER 16 AX u-tec	EK	1:2
8 043 64 009	ER 16 AX u-tec	IK 140 bar	1:2
$n_{max} = 12000 \text{ min}^{-1}$			

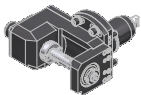

Winkel-Scheibenfräserkopf radial disk mill head

$\pm 10^\circ$ drehbar
 $\pm 10^\circ$ turnable

Mittenmaß / center distance $H=87,5$
auf 0° absteckbar / 0° can be pinned
kein Kühlmittel / no coolant
 $n_{max} = 3000 \text{ min}^{-1}$

8 037 64 023	$\varnothing 16$	2:1
8 037 65 008	$\varnothing 22$	2:1
8 037 64 003	$\varnothing 3/4"$	2:1
8 037 65 019	$\varnothing 1"$	2:1

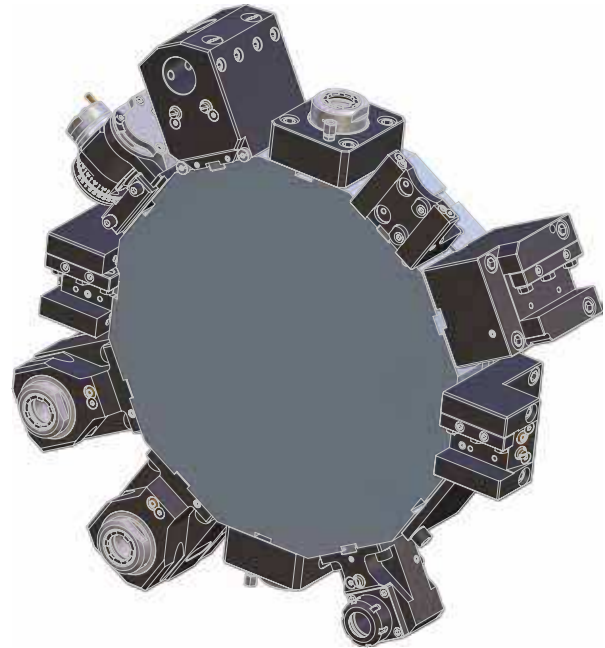

► Weitere Ausführungen auf Anfrage
further versions on request

► Zubehör ZB...*
accessories ZB...*



► easy-quick



► u-tec



feste Werkzeuge
static tool holders

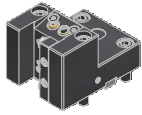

Kombi-Drehstahlhalter
universal turning holder
8 224 15 006 **Vierkant/square 25** EK
8 224 15 016 **Vierkant/square 1"** EK

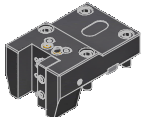

Kombi-Drehstahlhalter
universal turning holder
8 224 15 005 **Vierkant/square 25** EK
8 224 15 015 **Vierkant/square 1"** EK

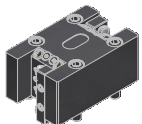

Kombi-Doppel-Drehstahlhalter
combi double turning holder
8 251 15 003 **Vierkant/square 25** EK
8 251 15 008 **Vierkant/square 1"** EK

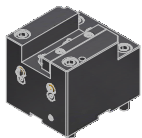

Kombi-Plandrehhalter
combi facing holder
8 244 15 005 **Vierkant/square 25** EK
8 244 15 006 **Vierkant/square 1"** EK



Bohrstangenhalter
boring bar holder
Mittenmaß / center distance H=72
8 240 18 028 **ø32** IK/EK
8 240 19 032 **ø40** IK/EK
8 240 19 044 **ø1,5"** IK/EK
8 240 19 048 **ø2"** IK/EK

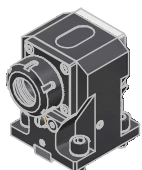

Spannzangenhalter
collet chuck holder
Mittenmaß / center distance H=72
8 240 16 021 **ER 32** IK/EK

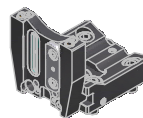
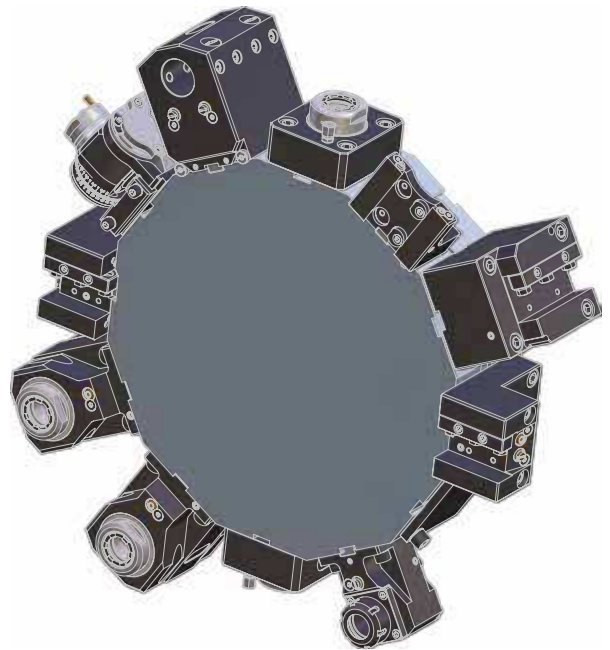

Abstechhalter
cut-off holder
höhenverstellbar / height adjustable
8 320 13 005 **SH 32** IK 70 bar

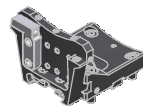

Abstechhalter
cut-off holder **phi HORN phi**
höhenverstellbar / height adjustable
8 320 19 000 **HORN System 845** IK 70 bar

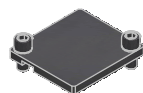

Abdeckblech
cover plate
8 200 03 005

► Weitere Ausführungen auf Anfrage
further versions on request

► Zubehör **ZB...***
accessories **ZB...*** 

► **easy-quick** 

► **u-tec** 

► **easy-quick HT Schnellwechselsystem**
easy-quick HT fast change system

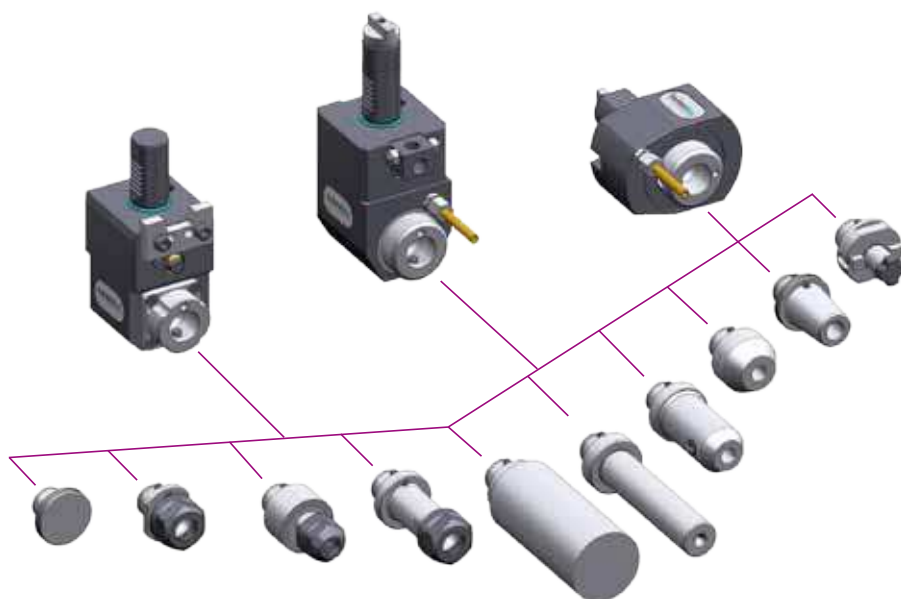

DAS Schnellwechselsystem von heimatec
für angetriebene und feste Werkzeuge

*THE fast change system of heimatec
for driven and static tools*

www.heimatec.de
Produkte / easy-quick

www.heimatec.com
products / easy-quick

► Ausführungen siehe Katalog
versions see catalogue

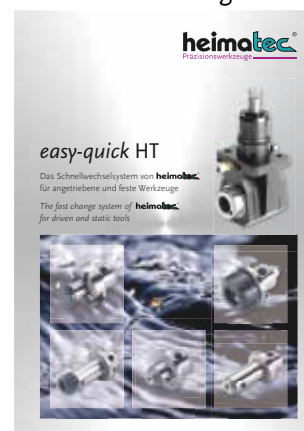

► **u-tec[®] UT Wechselsystem**
u-tec[®] UT change system

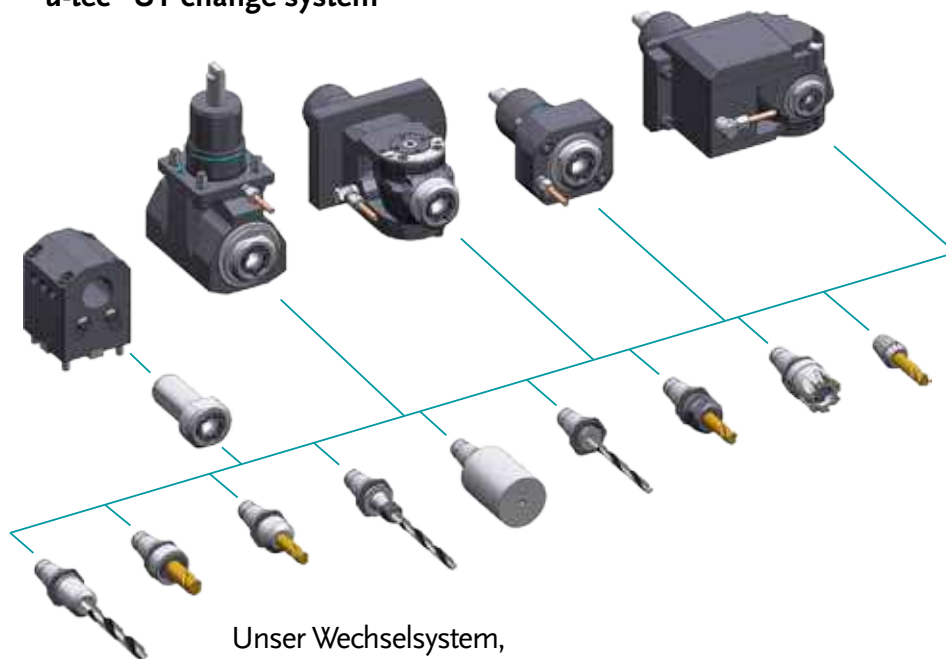

Unser Wechselsystem,
das ALLES möglich macht

Our change system,
that makes EVERYTHING possible

www.heimatec.de
Produkte / u-tec

www.heimatec.com
products / u-tec

► Ausführungen siehe Katalog
versions see catalogue



heimatec®

- heimatec®-Niederlassungen
heimatec® overseas branches
- unsere weltweiten Vertretungen
global representations of heimatec®

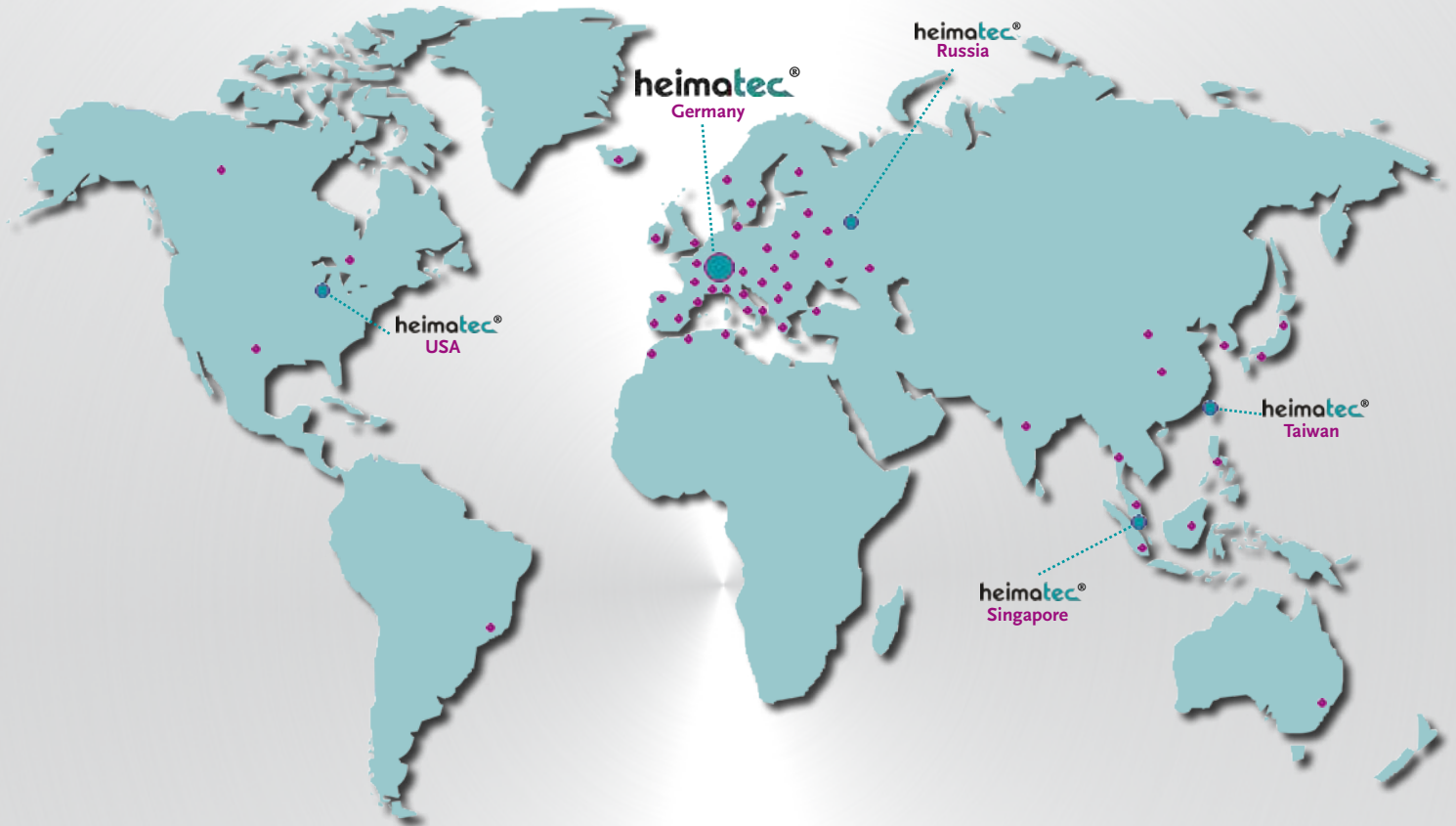

Hauptsitz/headquarters

heimatec® GmbH
Präzisionswerkzeuge
Carl-Benz-Straße 4
D- 77871 Renchen
Postfach 11 36
D- 77867 Renchen
Tel.: +49 (78 43) 94 66 0
Fax: +49 (78 43) 94 66 66
heimatec.de
info@heimatec.de

heimatec® Inc.
USA
usa.heimatec.com
USA@heimatec.com

heimatec®-Ost, JSC
Russia
ru.heimatec.com
Russia@heimatec.com

heimatec® Ltd.
Taiwan
tw.heimatec.com
Taiwan@heimatec.com

heimatec®
Singapore
sg.heimatec.com
Singapore@heimatec.com



Werkzeugkatalog

tool catalogue

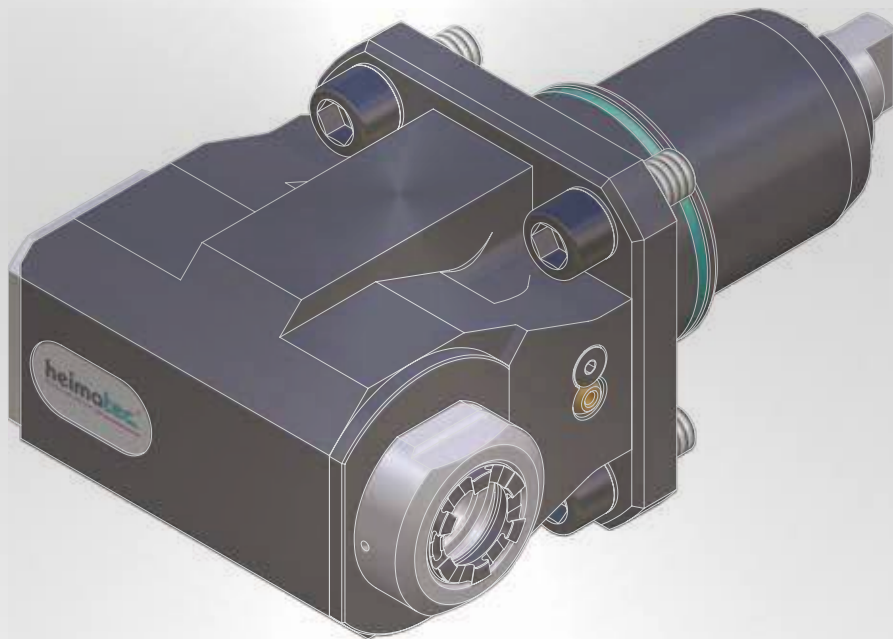

HYUNDAI WIA

L 300 MSA
L 300 LMSA
L 300 MSC



Hinweis zu den AGBs:

Diese finden Sie in unserem Internetauftritt unter

www.heimatec.de

Home/Impressum/AGB

Terms and conditions:

You will find them on our website

www.heimatec.com

Home/Imprint/Terms and Conditions

Das Katalog-Werk einschließlich aller seiner Teile ist urheberrechtlich geschützt. Jede Verwertung außerhalb der engen Grenzen des Urheberrechtsgesetzes ist ohne Zustimmung der Rechteeinhaber unzulässig und strafbar. Das gilt insbesondere für Vervielfältigungen, Übersetzungen, Mikroverfilmungen und die Einspeicherung und Verarbeitung in elektronischen Systemen.

heimatec® GmbH behält sich Änderungen technischer Art jederzeit ohne Vorankündigung vor. Dies gilt insbesondere bei Anpassungen an neue oder geänderte internationale Normen oder bei Weiterentwicklungen unserer Produkte oder Herstellungsprozesse.

This catalogue, including all its parts, is protected by copyright. Each use outside the restricted limitations of the Copyright Act is inadmissible and liable to prosecution without the consent of heimatec. This is particularly valid for duplication, translation, microfilming and feeding and processing in electronic systems.

heimatec® GmbH reserves the right of technical changes everytime without advance notice, which is particularly valid for adaptations to new or changed international standards, or to developments of our products or manufacturing processes.

angetriebene Werkzeuge

driven tools



Axial-Bohr- und Fräskopf

axial drilling and milling head

$n_{max} = 6000 \text{ min}^{-1}$

8 010 66 079	ER 32 AX u-tec	EK	1:1
8 010 66 081	ER 32 AX u-tec	IK 25 bar	1:1
8 010 66 046	ER 32 AX u-tec	IK 70 bar	1:1
8 010 67 025	easy-quick HT 5	EK	1:1
8 010 67 026	easy-quick HT 5	IK 25 bar	1:1
8 010 67 060	easy-quick HT 5	IK 70 bar	1:1



Axial-Bohr- und Fräskopf

axial drilling and milling head

$n_{max} = 24000 \text{ min}^{-1}$

8 013 64 008	ER 16 AX u-tec	EK	1:4
8 013 64 009	ER 16 AX u-tec	IK 70 bar	1:4



Axial-Bohr- und Fräskopf

axial drilling and milling head

$n_{max} = 6000 \text{ min}^{-1}$

8 011 65 014	Kombidorn/universal arbor 22	EK	1:1
8 011 65 011	Kombidorn/universal arbor 1"	EK	1:1



Axial-Bohr- und Fräskopf

axial drilling and milling head

Achsversatz / offset A=50

8 019 65 021	ER 25 AX u-tec	EK	1:1
8 019 65 022	ER 25 AX u-tec	IK 140 bar	1:1
$n_{max} = 6000 \text{ min}^{-1}$			
8 019 65 004	ER 25 AX u-tec	EK	1:2
8 019 65 027	ER 25 AX u-tec	IK 140 bar	1:2
$n_{max} = 12000 \text{ min}^{-1}$			
8 019 65 023	ER 25 AX u-tec	EK	2:1
8 019 65 024	ER 25 AX u-tec	IK 140 bar	2:1
$n_{max} = 3000 \text{ min}^{-1}$			
8 019 65 025	ER 25 AX u-tec	EK	1:3
8 019 65 026	ER 25 AX u-tec	IK 140 bar	1:3
$n_{max} = 15000 \text{ min}^{-1}$			

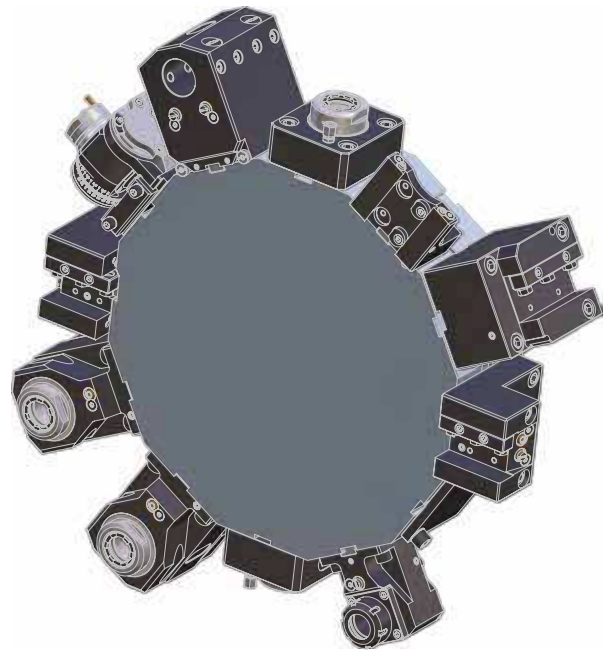

Winkel-Bohr- und Fräskopf

radial drilling and milling head

Mittenmaß / center distance H=100

$n_{max} = 6000 \text{ min}^{-1}$

8 030 66 045	ER 32 AX u-tec	EK	1:1
8 030 66 102	ER 32 AX u-tec	IK 140 bar	1:1
8 030 67 059	easy-quick HT 5	EK	1:1
8 030 67 073	easy-quick HT 5	IK 140 bar	1:1

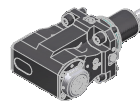

Axial-Bohr- und Fräskopf

axial drilling and milling head

Mittenmaß / center distance H=95

8 030 65 055	ER 25 AX u-tec	EK	1:2
8 030 65 063	ER 25 AX u-tec	IK 140 bar	1:2
$n_{max} = 12000 \text{ min}^{-1}$			
8 030 65 064	ER 25 AX u-tec	EK	1:3
8 030 65 065	ER 25 AX u-tec	IK 140 bar	1:3
$n_{max} = 18000 \text{ min}^{-1}$			

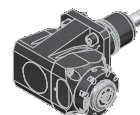

Winkel-Bohr- und Fräskopf

radial drilling and milling head

Mittenmaß / center distance H=100

$n_{max} = 18000 \text{ min}^{-1}$

8 030 64 024	ER 16 AX u-tec	EK	1:4
8 030 64 025	ER 16 AX u-tec	IK 140 bar	1:4

► Weitere Ausführungen auf Anfrage
further versions on request

► Zubehör ZB...*
accessories ZB...*

► easy-quick



► u-tec

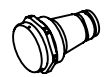

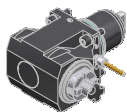

Winkel-Bohr- und Fräskopf radial drilling and milling head

Mittenmaß / center distance $H=100$
 $n_{max} = 6000 \text{ min}^{-1}$

8 031 65 016	Kombidorn/universal arbor 22	EK	1:1
8 031 65 011	Kombidorn/universal arbor 1"	EK	1:1



Winkel-Bohr- und Fräskopf radial drilling and milling head

Mittenmaß / center distance $H=110$
doppelspindlig / double spindle
 $n_{max} = 6000 \text{ min}^{-1}$

8 039 66 034	ER 32 AX u-tec	EK	1:1
8 039 67 012	easy-quick HT 5	EK	1:1



Schwenkkopf universal head

Mittenmaß / center distance $H=69$
Achsversatz / offset $A=60$

8 043 65 000	ER 25 AX u-tec	EK	1:1
8 043 65 004	ER 25 AX u-tec	IK 140 bar	1:1
$n_{max} = 6000 \text{ min}^{-1}$			
8 043 64 008	ER 16 AX u-tec	EK	1:2
8 043 64 009	ER 16 AX u-tec	IK 140 bar	1:2
$n_{max} = 12000 \text{ min}^{-1}$			

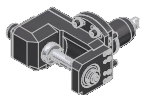

Winkel-Scheibenfräserkopf radial disk mill head

**±10° drehbar
±10° turnable**

Mittenmaß / center distance $H=87,5$
auf 0° absteckbar / 0° can be pinned
kein Kühlmittel / no coolant
 $n_{max} = 3000 \text{ min}^{-1}$

8 037 64 023	Ø 16	2:1
8 037 65 008	Ø 22	2:1
8 037 64 003	Ø 3/4"	2:1
8 037 65 019	Ø 1"	2:1

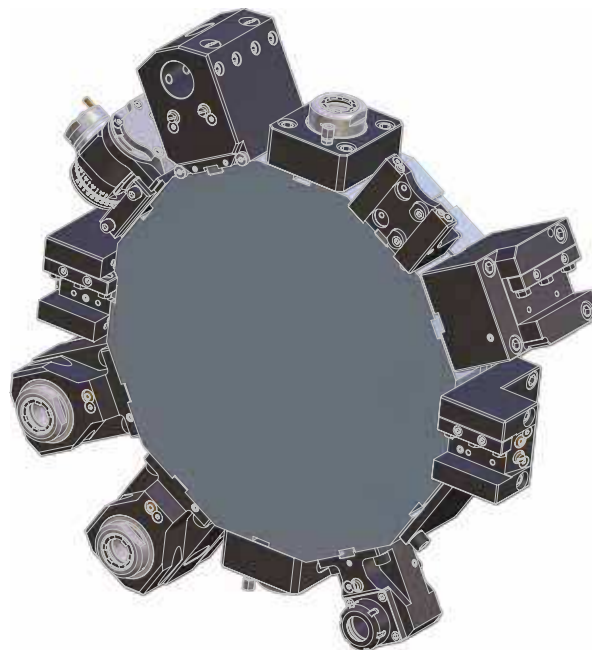

► Weitere Ausführungen auf Anfrage
further versions on request

► Zubehör ZB...*
accessories ZB...*



► easy-quick



► u-tec



feste Werkzeuge
static tool holders

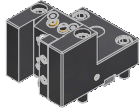

Kombi-Drehstahlhalter universal turning holder			
8 224 15 006	Vierkant/square 25		EK
8 224 15 016	Vierkant/square 1"		EK

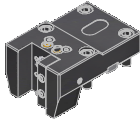

Kombi-Drehstahlhalter universal turning holder			
8 224 15 005	Vierkant/square 25		EK
8 224 15 015	Vierkant/square 1"		EK

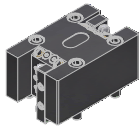

Kombi-Doppel-Drehstahlhalter combi double turning holder			
8 251 15 003	Vierkant/square 25		EK
8 251 15 008	Vierkant/square 1"		EK

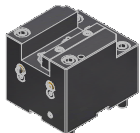

Kombi-Plandrehhalter combi facing holder			
8 244 15 005	Vierkant/square 25		EK
8 244 15 006	Vierkant/square 1"		EK



Bohrstangenhalter boring bar holder			
<i>Mittenmaß / center distance H=100</i>			
8 240 18 049	ø32		IK/EK
8 240 19 043	ø40		IK/EK
8 240 19 051	ø50		IK/EK
8 240 17 063	ø1 1/4"		IK/EK
8 240 19 058	ø1 1/2"		IK/EK
8 240 19 062	ø2"		IK/EK

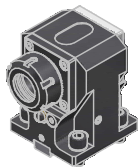

Spannzangenhalter collet chuck holder			
<i>Mittenmaß / center distance H=100</i>			
8 240 16 026	ER 32		IK/EK

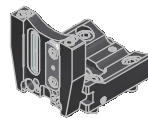
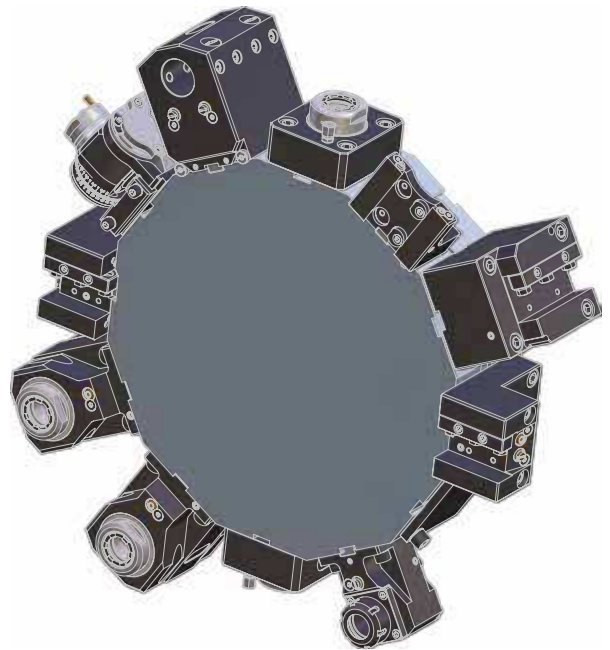

Abstechhalter cut-off holder			
<i>höhenverstellbar / height adjustable</i>			
8 320 13 005	SH 32		IK 70 bar



Abstechhalter cut-off holder			
<i>höhenverstellbar / height adjustable</i>			
8 320 19 000	HORN System 845		IK 70 bar

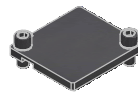

Abdeckblech cover plate			
8 200 03 005			

► Weitere Ausführungen auf Anfrage
further versions on request

► Zubehör **ZB...***
accessories **ZB...***

► **easy-quick**

► **u-tec**

► **easy-quick HT Schnellwechselsystem**
easy-quick HT fast change system

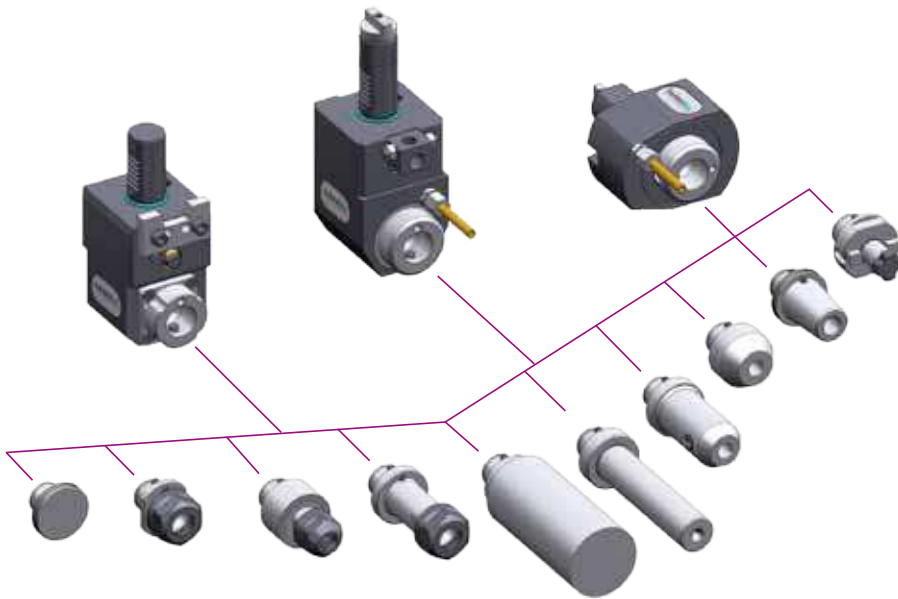

DAS Schnellwechselsystem von heimatec
für angetriebene und feste Werkzeuge

*THE fast change system of heimatec
for driven and static tools*

www.heimatec.de
Produkte / easy-quick

www.heimatec.com
products / easy-quick

► Ausführungen siehe Katalog
versions see catalogue



► **u-tec[®] UT Wechselsystem**
u-tec[®] UT change system

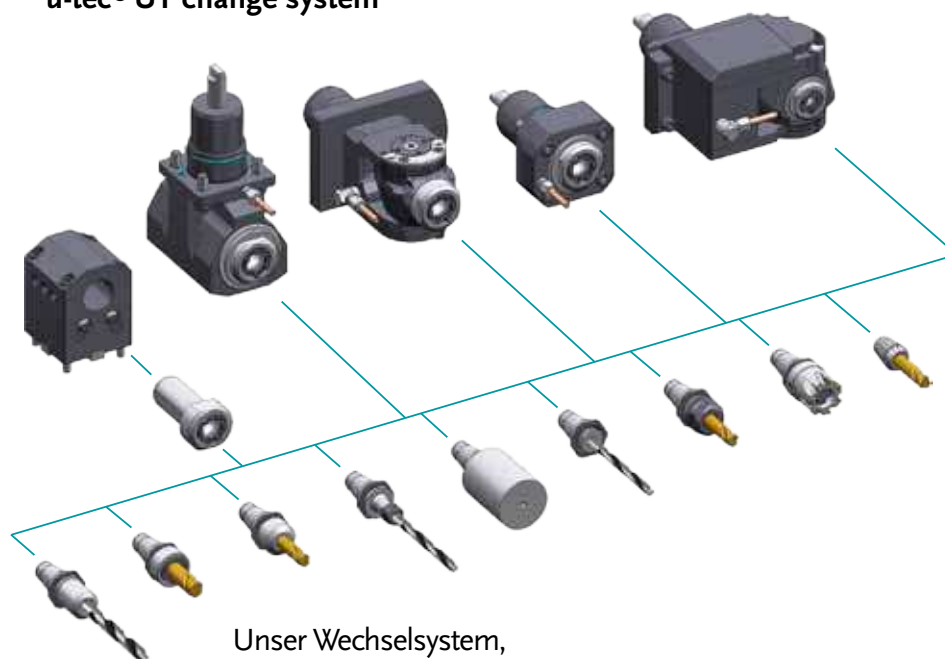

Unser Wechselsystem,
das ALLES möglich macht

Our change system,
that makes EVERYTHING possible

www.heimatec.de
Produkte / u-tec

www.heimatec.com
products / u-tec

► Ausführungen siehe Katalog
versions see catalogue



heimatec®

- heimatec®-Niederlassungen
heimatec® overseas branches
- unsere weltweiten Vertretungen
global representations of heimatec®

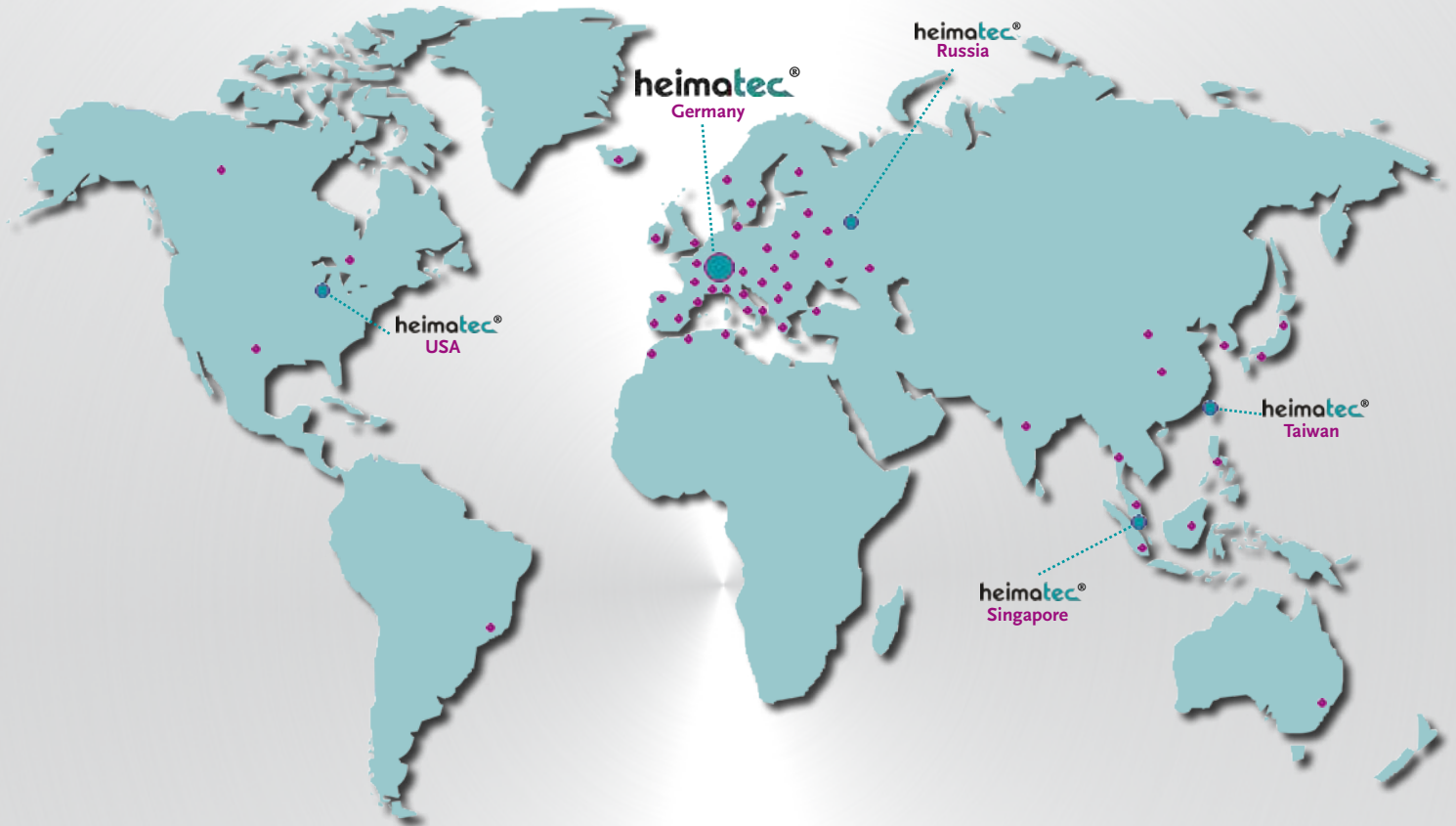

Hauptsitz/headquarters

heimatec® GmbH
Präzisionswerkzeuge
Carl-Benz-Straße 4
D- 77871 Renchen
Postfach 11 36
D- 77867 Renchen
Tel.: +49 (78 43) 94 66 0
Fax: +49 (78 43) 94 66 66
heimatec.de
info@heimatec.de

heimatec® Inc.
USA
usa.heimatec.com
USA@heimatec.com

heimatec®-Ost, JSC
Russia
ru.heimatec.com
Russia@heimatec.com

heimatec® Ltd.
Taiwan
tw.heimatec.com
Taiwan@heimatec.com

heimatec®
Singapore
sg.heimatec.com
Singapore@heimatec.com



Werkzeugkatalog

tool catalogue

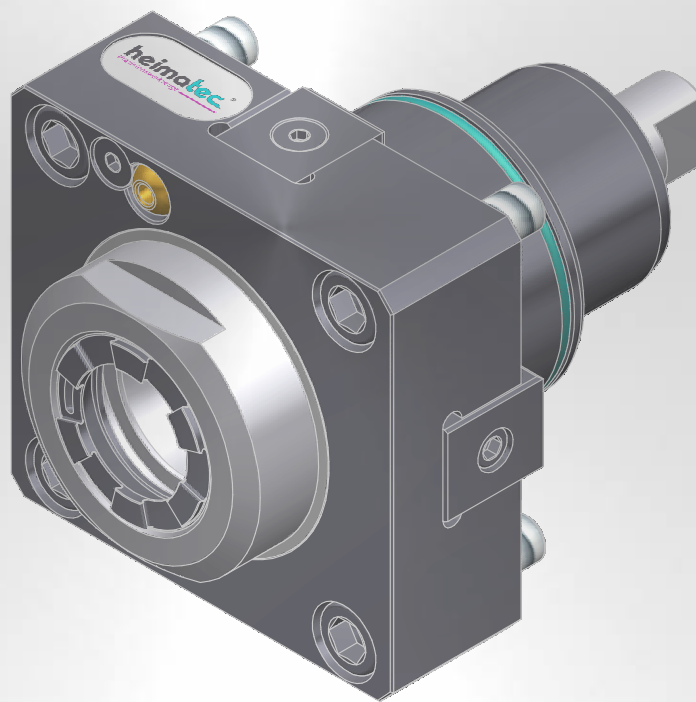

HYUNDAI WIA

L 400 MA
L 400 MC
L 400 LMC



Hinweis zu den AGBs:

Diese finden Sie in unserem Internetauftritt unter

www.heimatec.de

Home/Impressum/AGB

Terms and conditions:

You will find them on our website

www.heimatec.com

Home/Imprint/Terms and Conditions

Das Katalog-Werk einschließlich aller seiner Teile ist urheberrechtlich geschützt. Jede Verwertung außerhalb der engen Grenzen des Urheberrechtsgesetzes ist ohne Zustimmung der Rechteeinhaber unzulässig und strafbar. Das gilt insbesondere für Vervielfältigungen, Übersetzungen, Mikroverfilmungen und die Einspeicherung und Verarbeitung in elektronischen Systemen.

heimatec® GmbH behält sich Änderungen technischer Art jederzeit ohne Vorankündigung vor. Dies gilt insbesondere bei Anpassungen an neue oder geänderte internationale Normen oder bei Weiterentwicklungen unserer Produkte oder Herstellungsprozesse.

This catalogue, including all its parts, is protected by copyright. Each use outside the restricted limitations of the Copyright Act is inadmissible and liable to prosecution without the consent of heimatec. This is particularly valid for duplication, translation, microfilming and feeding and processing in electronic systems.

heimatec® GmbH reserves the right of technical changes everytime without advance notice, which is particularly valid for adaptions to new or changed international standards, or to developments of our products or manufacturing processes.

angetriebene Werkzeuge driven tools



Axial-Bohr- und Fräskopf axial drilling and milling head

$n_{max} = 4000 \text{ min}^{-1}$

8 010 67 059	ER 40 AX u-tec	EK	1:1
8 010 67 039	ER 40 AX u-tec	IK 25 bar	1:1
8 010 67 061	ER 40 AX u-tec	IK 70 bar	1:1
8 010 68 031	easy-quick HT 6	EK	1:1
8 010 68 032	easy-quick HT 6	IK 25 bar	1:1
8 010 68 037	easy-quick HT 6	IK 70 bar	1:1



Axial-Bohr- und Fräskopf axial drilling and milling head

$n_{max} = 4000 \text{ min}^{-1}$

8 011 65 007	Kombidom/universal arbor 22	EK	1:1
8 011 65 016	Kombidom/universal arbor 1"	EK	1:1



Winkel-Bohr- und Fräskopf radial drilling and milling head

Mittenmaß / center distance H=72

$n_{max} = 4000 \text{ min}^{-1}$

8 030 67 074	ER 40 AX u-tec	EK	1:1
8 030 67 071	ER 40 AX u-tec	IK 140 bar	1:1
8 030 68 023	easy-quick HT 6	EK	1:1
8 030 68 022	easy-quick HT 6	IK 140 bar	1:1

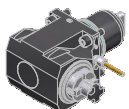

Winkel-Bohr- und Fräskopf radial drilling and milling head

Mittenmaß / center distance H=72

$n_{max} = 4000 \text{ min}^{-1}$

8 031 65 020	Kombidom/universal arbor 22	EK	1:1
8 031 65 021	Kombidom/universal arbor 1"	EK	1:1

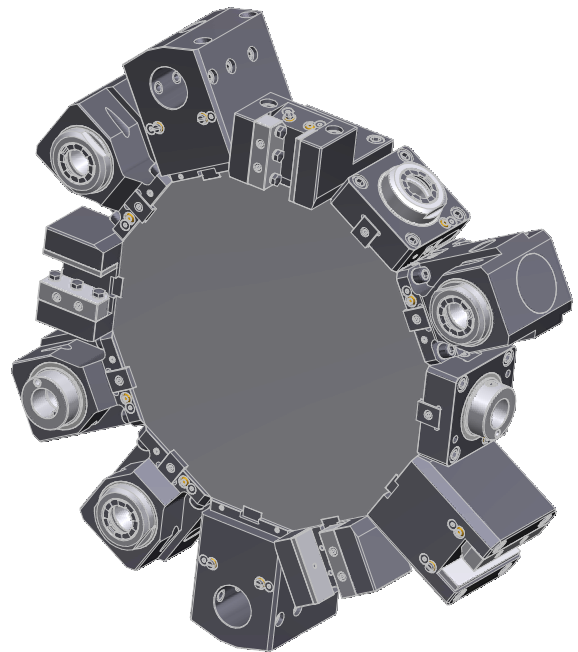

► Weitere Ausführungen auf Anfrage
further versions on request

► Zubehör ZB...*
accessories ZB...*



► easy-quick



► u-tec



feste Werkzeuge
static tool holders

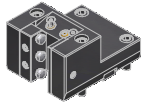

Kombi-Drehstahlhalter
universal turning holder

8 224 26 002	Vierkant/square 32	EK
8 224 26 008	Vierkant/square 1 1/4"	EK

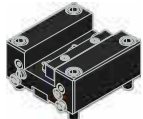

Kombi-Plandrehhalter
combi facing holder

8 244 26 002	Vierkant/square 32	EK
8 244 26 008	Vierkant/square 1 1/4"	EK

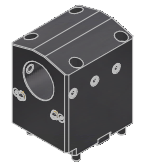

Bohrstangenhalter
boring bar holder

Mittenmaß / center distance H=110

8 240 29 025	ø40	IK/EK
8 240 29 026	ø50	IK/EK
8 240 29 020	ø60	IK/EK
8 240 29 029	ø2"	IK/EK
8 240 29 036	ø2 1/2"	IK/EK

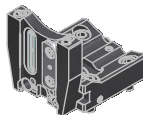

Abstechhalter
cut-off holder

höhenverstellbar / height adjustable

8 320 23 011	SH 32	IK 70 bar
--------------	--------------	-----------

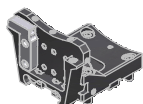

Abstechhalter
cut-off holder

höhenverstellbar / height adjustable

8 320 29 000	HORN System 845	IK 70 bar
--------------	------------------------	-----------

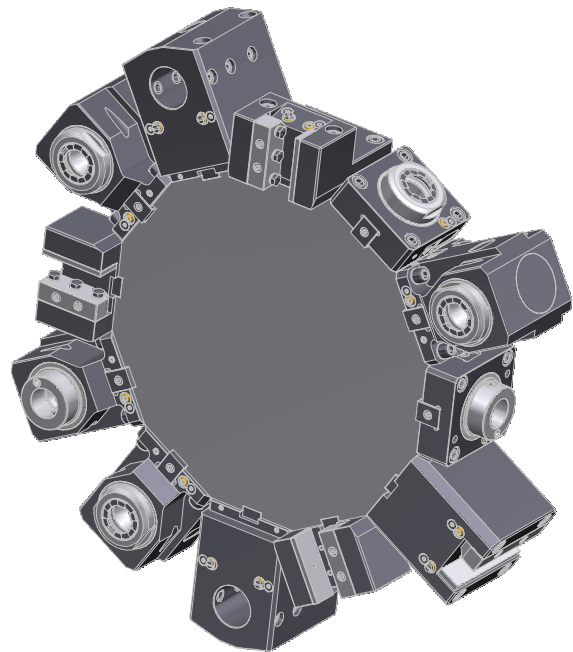

► Weitere Ausführungen auf Anfrage
further versions on request

► Zubehör **ZB...***
accessories **ZB...***



► **easy-quick**



► **u-tec**



- ▶ *easy-quick* HT Schnellwechselsystem
easy-quick HT *fast change system*

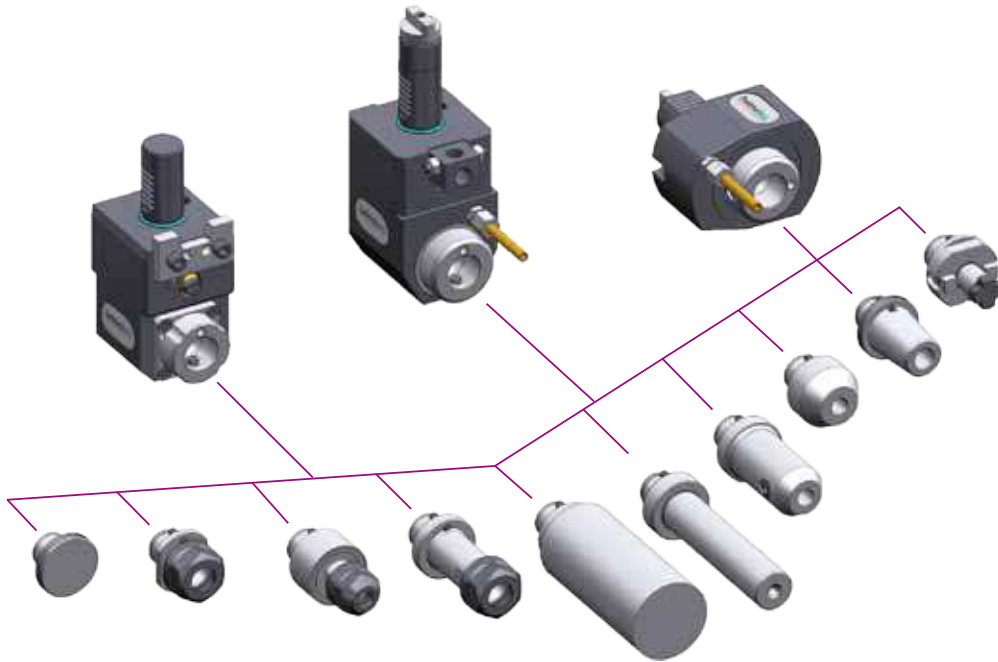

DAS Schnellwechselsystem von heimatec
für angetriebene und feste Werkzeuge

*THE fast change system of heimatec
for driven and static tools*

- ▶ Ausführungen siehe Katalog
versions see catalogue

www.heimatec.de
Produkte / easy-quick

www.heimatec.com
products / easy-quick



► **u-tec[®] UT Wechselsystem**
u-tec[®] UT change system

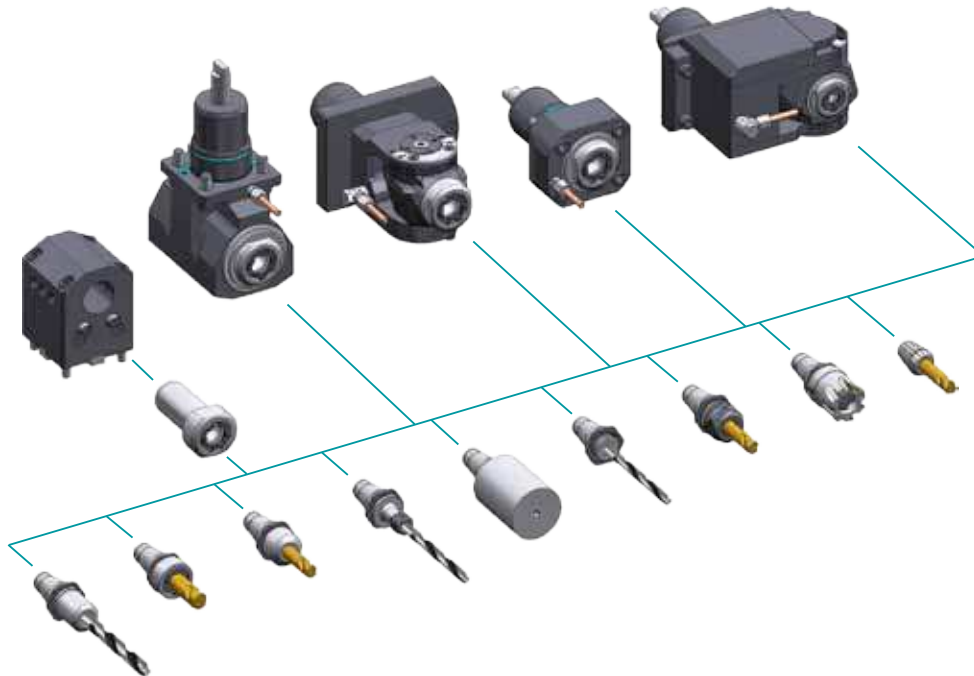

Unser Wechselsystem,
das ALLES möglich macht

Our change system,
that makes EVERYTHING possible

► Ausführungen siehe Katalog
versions see catalogue



www.heimatec.de
Produkte / u-tec

www.heimatec.com
products / u-tec

► **Zubehör**
accessories



► Ausführungen siehe Katalog
versions see catalogue



www.heimatec.de
Produkte / Zubehör

www.heimatec.com
products / accessories

heimatec®

- heimatec®-Niederlassungen
heimatec® overseas branches
- unsere weltweiten Vertretungen
global representations of heimatec®

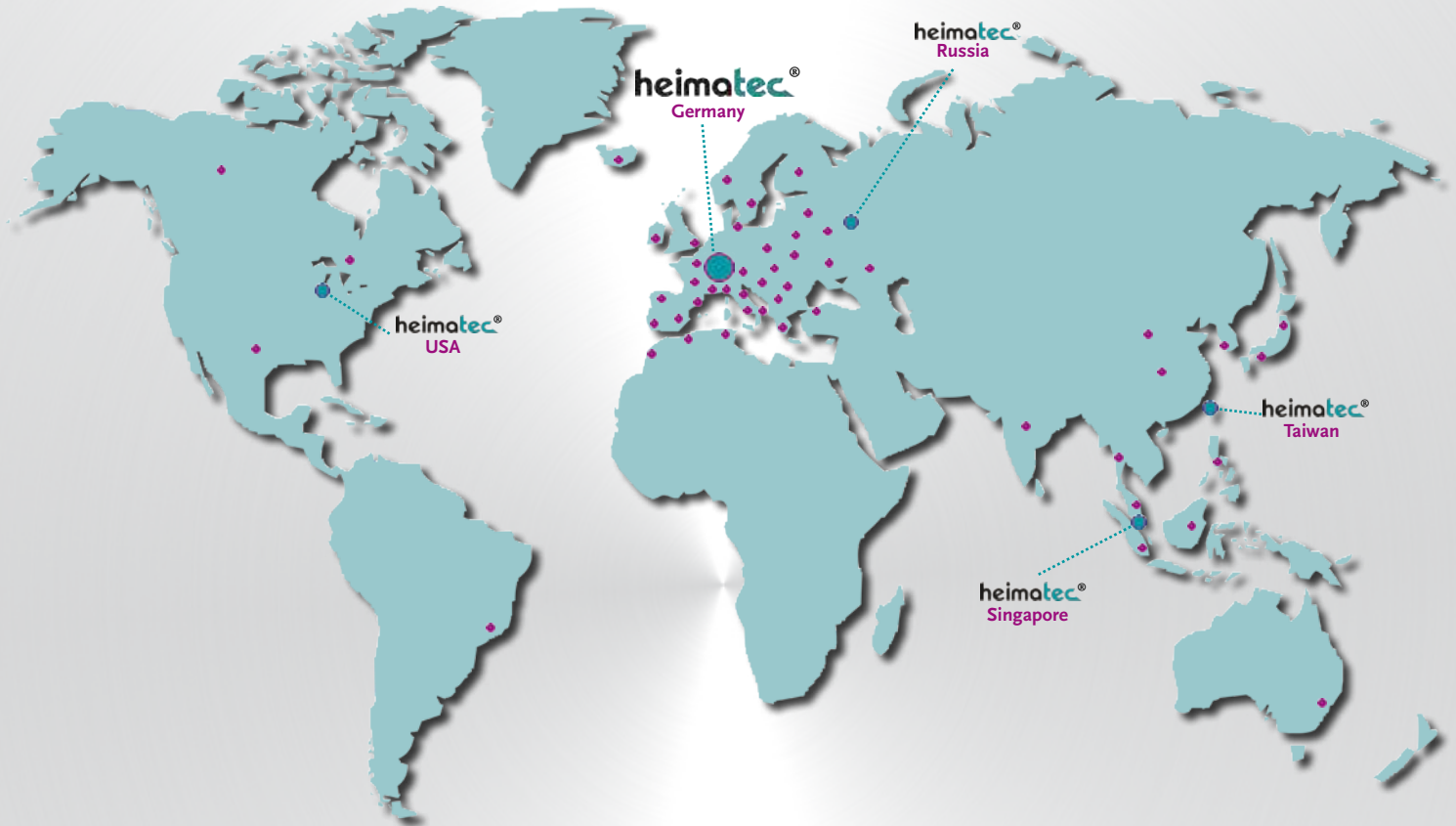

Hauptsitz/headquarters

heimatec® GmbH
Präzisionswerkzeuge
Carl-Benz-Straße 4
D- 77871 Renchen
Postfach 11 36
D- 77867 Renchen
Tel.: +49 (78 43) 94 66 0
Fax: +49 (78 43) 94 66 66
heimatec.de
info@heimatec.de

heimatec® Inc.
USA
usa.heimatec.com
USA@heimatec.com

heimatec®-Ost, JSC
Russia
ru.heimatec.com
Russia@heimatec.com

heimatec® Ltd.
Taiwan
tw.heimatec.com
Taiwan@heimatec.com

heimatec®
Singapore
sg.heimatec.com
Singapore@heimatec.com



Werkzeugkatalog

tool catalogue

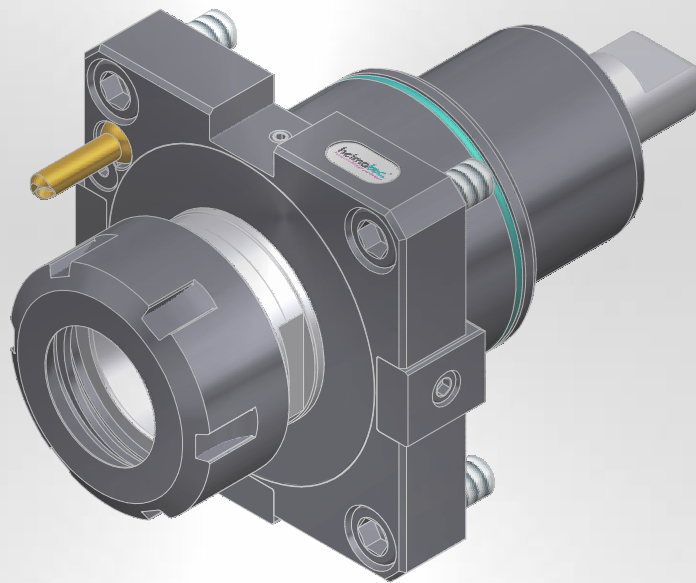

HYUNDAI WIA

L 600 MA/LMA

L 700 MA/LMA



Hinweis zu den AGBs:

Diese finden Sie in unserem Internetauftritt unter

www.heimatec.de

Home/Impressum/AGB

Terms and conditions:

You will find them on our website

www.heimatec.com

Home/Imprint/Terms and Conditions

Das Katalog-Werk einschließlich aller seiner Teile ist urheberrechtlich geschützt. Jede Verwertung außerhalb der engen Grenzen des Urheberrechtsgesetzes ist ohne Zustimmung der Rechteeinhaber unzulässig und strafbar. Das gilt insbesondere für Vervielfältigungen, Übersetzungen, Mikroverfilmungen und die Einspeicherung und Verarbeitung in elektronischen Systemen.

heimatec® GmbH behält sich Änderungen technischer Art jederzeit ohne Vorankündigung vor. Dies gilt insbesondere bei Anpassungen an neue oder geänderte internationale Normen oder bei Weiterentwicklungen unserer Produkte oder Herstellungsprozesse.

This catalogue, including all its parts, is protected by copyright. Each use outside the restricted limitations of the Copyright Act is inadmissible and liable to prosecution without the consent of heimatec. This is particularly valid for duplication, translation, microfilming and feeding and processing in electronic systems.

heimatec® GmbH reserves the right of technical changes everytime without advance notice, which is particularly valid for adaptations to new or changed international standards, or to developments of our products or manufacturing processes.

angetriebene Werkzeuge
driven tools



Axial-Bohr- und Fräskopf
axial drilling and milling head

$n_{max} = 4000 \text{ min}^{-1}$

8 010 77 007	ER 40 AX u-tec	EK	1:1
8 010 77 009	ER 40 AX u-tec	IK 25 bar	1:1
8 010 77 010	ER 40 AX u-tec	IK 70 bar	1:1
8 010 78 000	ER 50	EK	1:1
8 010 78 001	ER 50	IK 25 bar	1:1
8 010 78 013	ER 50	IK 70 bar	1:1
8 010 78 002	easy-quick HT 6	EK	1:1
8 010 78 005	easy-quick HT 6	IK 25 bar	1:1
8 010 78 010	easy-quick HT 6	IK 70 bar	1:1



Winkel-Bohr- und Fräskopf
radial drilling and milling head

Mittenmaß / center distance $H=85$
 $n_{max} = 4000 \text{ min}^{-1}$

8 030 77 004	ER 40 AX u-tec	EK	1:1
8 030 77 008	ER 40 AX u-tec	IK 140 bar	1:1
8 030 78 000	ER 50	EK	1:1
8 030 78 001	ER 50	IK 140 bar	1:1
8 030 78 002	easy-quick HT 6	EK	1:1
8 030 78 004	easy-quick HT 6	IK 140 bar	1:1



Schwenkkopf
universal head

$n_{max} = 4000 \text{ min}^{-1}$

8 040 75 000	ER 25 AX u-tec	EK	1:1
8 040 75 003	ER 25 AX u-tec	IK 140 bar	1:1

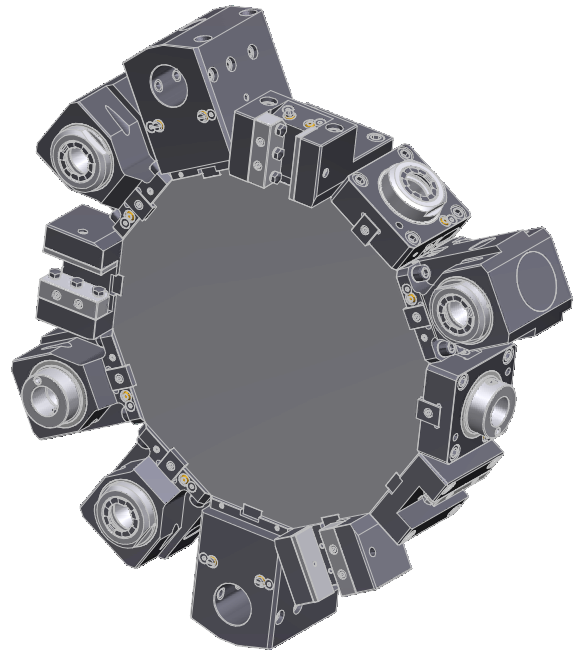

► Weitere Ausführungen auf Anfrage
further versions on request

► Zubehör **ZB...***
accessories **ZB...***



► **easy-quick**



► **u-tec**



feste Werkzeuge
static tool holders

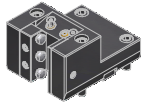

Kombi-Drehstahlhalter
universal turning holder

8 224 26 000	Vierkant/square 32	EK
8 224 26 004	Vierkant/square 1 1/4"	EK

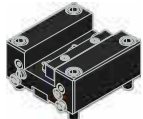

Kombi-Plandrehhalter
combi facing holder

8 244 26 000	Vierkant/square 32	EK
8 244 26 009	Vierkant/square 1 1/4"	EK

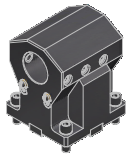

Bohrstangenhalter
boring bar holder

Mittenmaß / center distance H=110

8 240 29 013	ø50	IK/EK
8 240 29 014	ø60	IK/EK
8 240 29 038	ø2"	IK/EK
8 240 29 039	ø2 1/2"	IK/EK

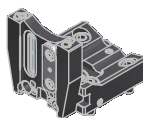

Abstechhalter
cut-off holder

höhenverstellbar / height adjustable

8 320 23 015	SH 32	IK 70 bar
--------------	--------------	-----------

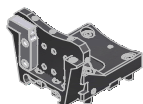

Abstechhalter
cut-off holder



höhenverstellbar / height adjustable

8 320 29 004	HORN System 845	IK 70 bar
--------------	------------------------	-----------

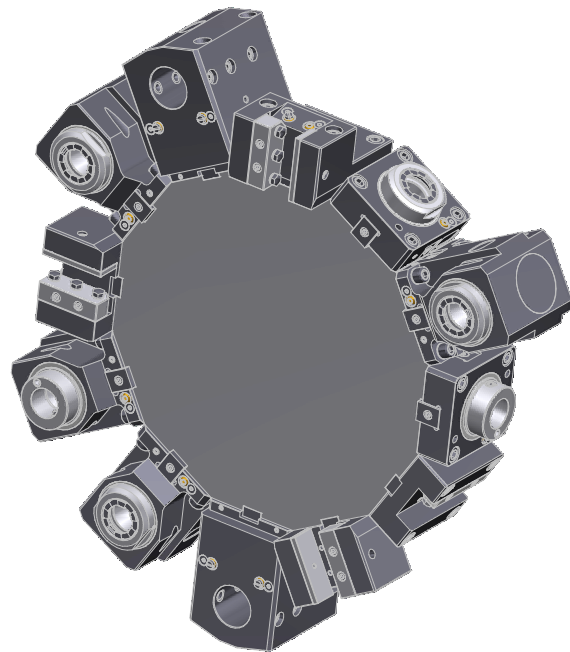

HYUNDAI WIA L 600 / 700 - MA/LMA

▶ Weitere Ausführungen auf Anfrage
further versions on request

▶ Zubehör **ZB...***
accessories **ZB...***



▶ **easy-quick**



▶ **u-tec**



- ▶ *easy-quick* HT Schnellwechselsystem
easy-quick HT *fast change system*

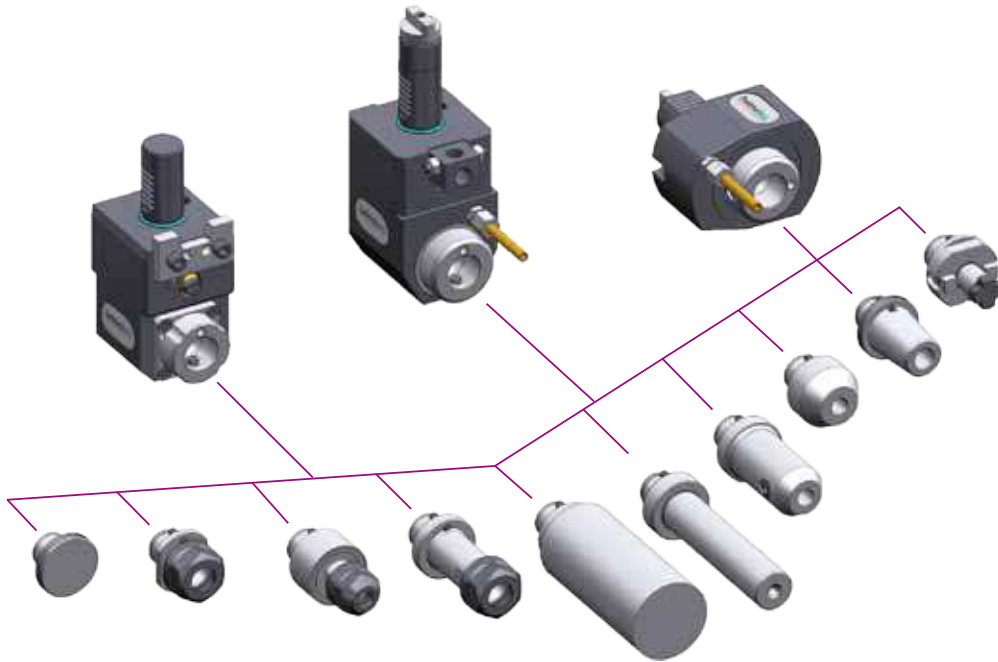

DAS Schnellwechselsystem von heimatec
für angetriebene und feste Werkzeuge

*THE fast change system of heimatec
for driven and static tools*

- ▶ Ausführungen siehe Katalog
versions see catalogue

www.heimatec.de
Produkte / easy-quick

www.heimatec.com
products / easy-quick



► **u-tec[®] UT Wechselsystem**
u-tec[®] UT change system

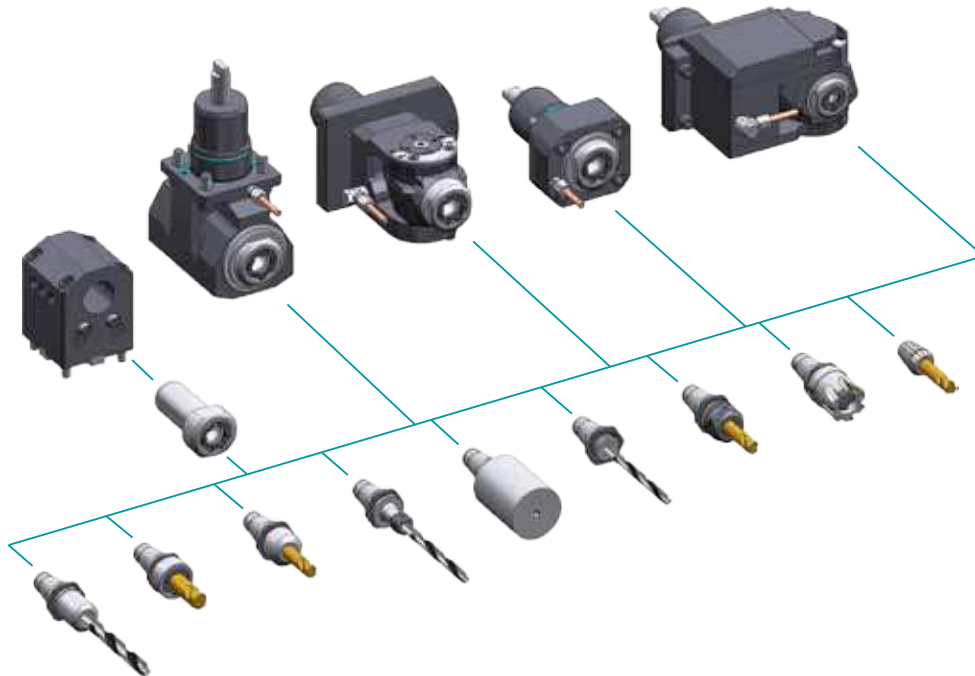

Unser Wechselsystem,
das ALLES möglich macht

Our change system,
that makes EVERYTHING possible

► Ausführungen siehe Katalog
versions see catalogue



www.heimatec.de
Produkte / u-tec

www.heimatec.com
products / u-tec

► **Zubehör**
accessories



► Ausführungen siehe Katalog
versions see catalogue



www.heimatec.de
Produkte / Zubehör

www.heimatec.com
products / accessories

heimatec®

- heimatec®-Niederlassungen
heimatec® overseas branches
- unsere weltweiten Vertretungen
global representations of heimatec®

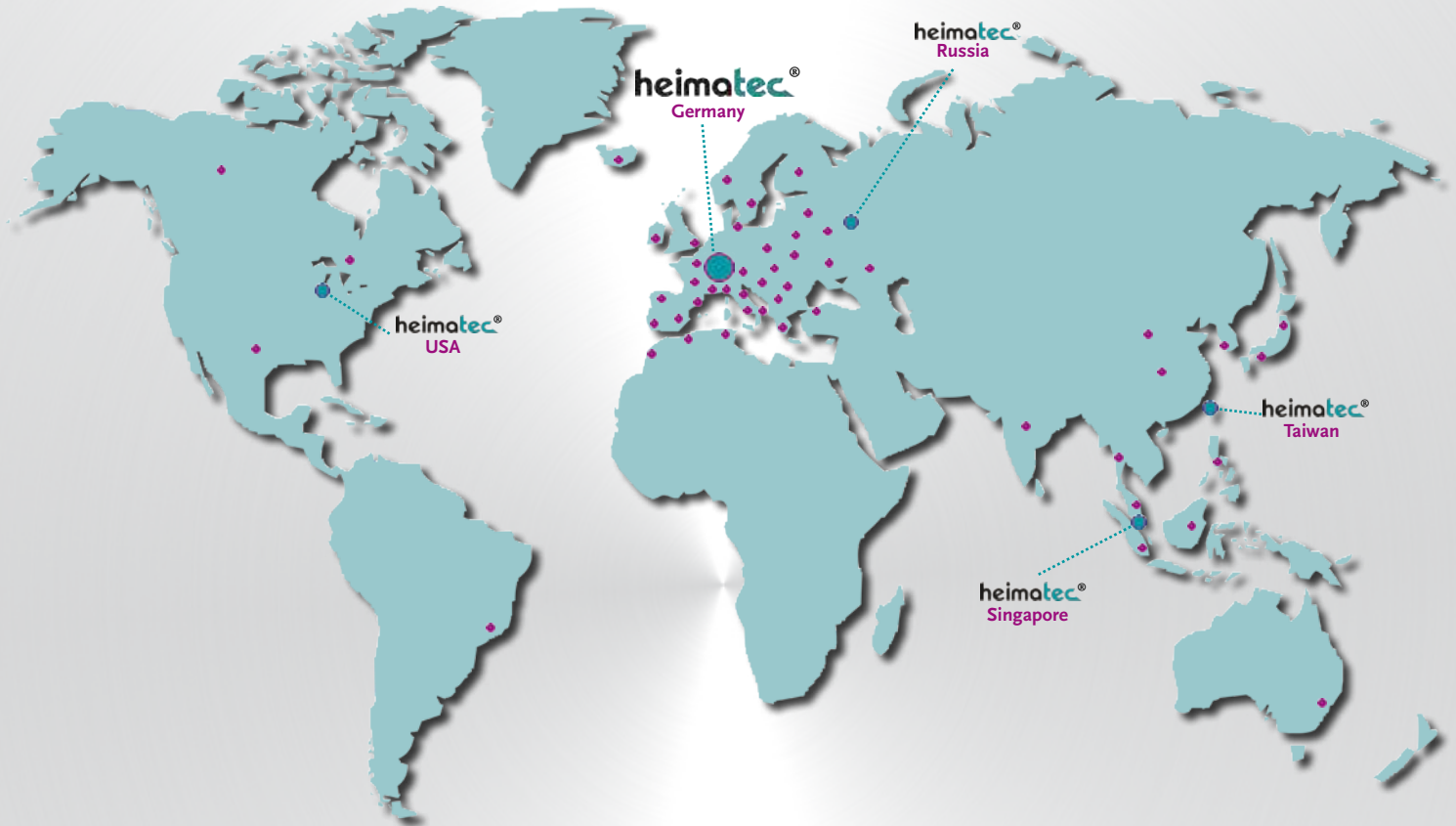

Hauptsitz/headquarters

heimatec® GmbH
Präzisionswerkzeuge
Carl-Benz-Straße 4
D- 77871 Renchen
Postfach 11 36
D- 77867 Renchen
Tel.: +49 (78 43) 94 66 0
Fax: +49 (78 43) 94 66 66
heimatec.de
info@heimatec.de

heimatec® Inc.
USA
usa.heimatec.com
USA@heimatec.com

heimatec®-Ost, JSC
Russia
ru.heimatec.com
Russia@heimatec.com

heimatec® Ltd.
Taiwan
tw.heimatec.com
Taiwan@heimatec.com

heimatec®
Singapore
sg.heimatec.com
Singapore@heimatec.com



Werkzeugkatalog

tool catalogue

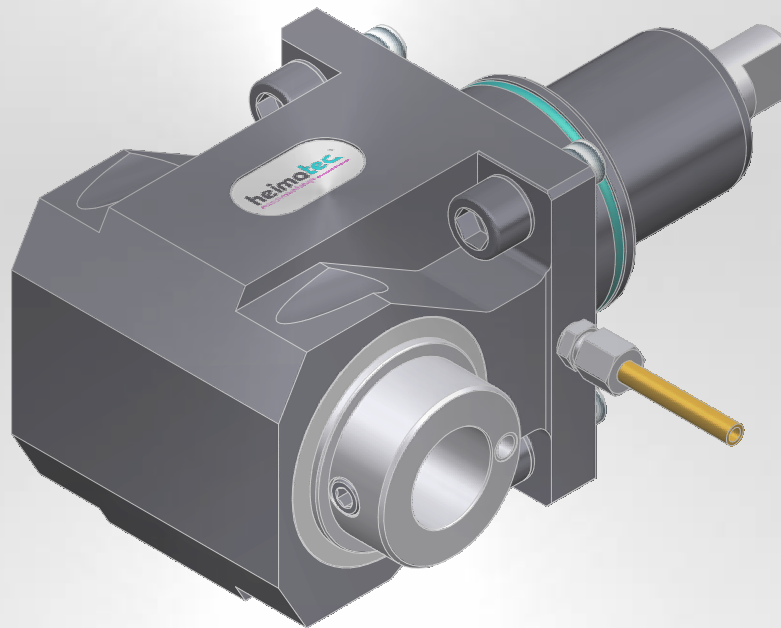

HYUNDAI WIA

L 2100 Y

L 2100 SY



Hinweis zu den AGBs:

Diese finden Sie in unserem Internetauftritt unter

www.heimatec.de

Home/Impressum/AGB

Terms and conditions:

You will find them on our website

www.heimatec.com

Home/Imprint/Terms and Conditions

Das Katalog-Werk einschließlich aller seiner Teile ist urheberrechtlich geschützt. Jede Verwertung außerhalb der engen Grenzen des Urheberrechtsgesetzes ist ohne Zustimmung der Rechteeinhaber unzulässig und strafbar. Das gilt insbesondere für Vervielfältigungen, Übersetzungen, Mikroverfilmungen und die Einspeicherung und Verarbeitung in elektronischen Systemen.

heimatec® GmbH behält sich Änderungen technischer Art jederzeit ohne Vorankündigung vor. Dies gilt insbesondere bei Anpassungen an neue oder geänderte internationale Normen oder bei Weiterentwicklungen unserer Produkte oder Herstellungsprozesse.

This catalogue, including all its parts, is protected by copyright. Each use outside the restricted limitations of the Copyright Act is inadmissible and liable to prosecution without the consent of heimatec. This is particularly valid for duplication, translation, microfilming and feeding and processing in electronic systems.

heimatec® GmbH reserves the right of technical changes everytime without advance notice, which is particularly valid for adaptions to new or changed international standards, or to developments of our products or manufacturing processes.

angetriebene Werkzeuge

driven tools

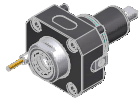

Axial-Bohr- und Fräskopf

axial drilling and milling head

$n_{max} = 6000 \text{ min}^{-1}$

8 010 66 079	ER 32 AX u-tec	EK	1:1
8 010 66 081	ER 32 AX u-tec	IK 25 bar	1:1
8 010 66 046	ER 32 AX u-tec	IK 70 bar	1:1
8 010 67 025	easy-quick HT 5	EK	1:1
8 010 67 026	easy-quick HT 5	IK 25 bar	1:1
8 010 67 060	easy-quick HT 5	IK 70 bar	1:1



Axial-Bohr- und Fräskopf

axial drilling and milling head

$n_{max} = 24000 \text{ min}^{-1}$

8 013 64 008	ER 16 AX u-tec	EK	1:4
8 013 64 009	ER 16 AX u-tec	IK 70 bar	1:4



Axial-Bohr- und Fräskopf

axial drilling and milling head

$n_{max} = 6000 \text{ min}^{-1}$

8 011 65 014	Kombidorn/universal arbor 22	EK	1:1
8 011 65 011	Kombidorn/universal arbor 1"	EK	1:1



Axial-Bohr- und Fräskopf

axial drilling and milling head

Achsversatz / offset A=50

8 019 65 021	ER 25 AX u-tec	EK	1:1
8 019 65 022	ER 25 AX u-tec	IK 140 bar	1:1
$n_{max} = 6000 \text{ min}^{-1}$			
8 019 65 004	ER 25 AX u-tec	EK	1:2
8 019 65 027	ER 25 AX u-tec	IK 140 bar	1:2
$n_{max} = 12000 \text{ min}^{-1}$			
8 019 65 023	ER 25 AX u-tec	EK	2:1
8 019 65 024	ER 25 AX u-tec	IK 140 bar	2:1
$n_{max} = 3000 \text{ min}^{-1}$			
8 019 65 025	ER 25 AX u-tec	EK	1:3
8 019 65 026	ER 25 AX u-tec	IK 140 bar	1:3
$n_{max} = 15000 \text{ min}^{-1}$			

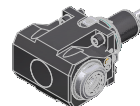
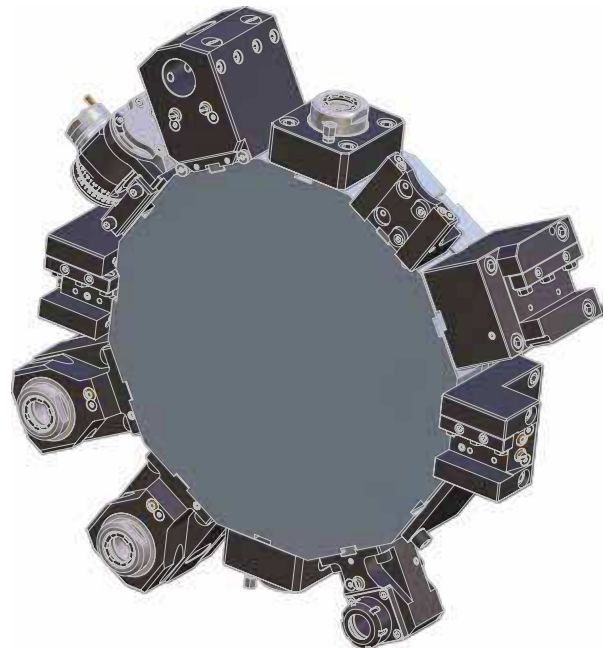

Winkel-Bohr- und Fräskopf

radial drilling and milling head

Mittenmaß / center distance H=72
 $n_{max} = 6000 \text{ min}^{-1}$

8 030 66 097	ER 32 AX u-tec	EK	1:1
8 030 66 098	ER 32 AX u-tec	IK 140 bar	1:1
8 030 67 025	easy-quick HT 5	EK	1:1
8 030 67 075	easy-quick HT 5	IK 140 bar	1:1

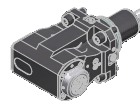

Axial-Bohr- und Fräskopf

axial drilling and milling head

Mittenmaß / center distance H=95

8 030 65 055	ER 25 AX u-tec	EK	1:2
8 030 65 063	ER 25 AX u-tec	IK 140 bar	1:2
$n_{max} = 12000 \text{ min}^{-1}$			
8 030 65 064	ER 25 AX u-tec	EK	1:3
8 030 65 065	ER 25 AX u-tec	IK 140 bar	1:3
$n_{max} = 18000 \text{ min}^{-1}$			

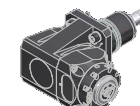

Winkel-Bohr- und Fräskopf

radial drilling and milling head

Mittenmaß / center distance H=72
 $n_{max} = 24000 \text{ min}^{-1}$

8 030 64 021	ER 16 AX u-tec	EK	1:4
8 030 64 023	ER 16 AX u-tec	IK 140 bar	1:4

► Weitere Ausführungen auf Anfrage
further versions on request

► Zubehör ZB...*
accessories ZB...*

► easy-quick



► u-tec



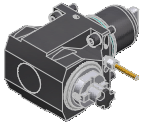

Winkel-Bohr- und Fräskopf radial drilling and milling head

Mittenmaß / center distance $H=72$
 $n_{max} = 6000 \text{ min}^{-1}$

8 031 65 015	Kombidorn/universal arbor 22	EK	1:1
8 031 65 010	Kombidorn/universal arbor 1"	EK	1:1

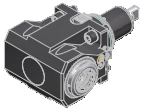

Winkel-Bohr- und Fräskopf radial drilling and milling head

Mittenmaß / center distance $H=72$
doppelspindlig / double spindle
 $n_{max} = 6000 \text{ min}^{-1}$

8 039 66 025	ER 32 AX u-tec	EK	1:1
8 039 67 009	easy-quick HT 5	EK	1:1



Schwenkkopf universal head

Mittenmaß / center distance $H=69$
Achsversatz / offset $A=60$

8 043 65 000	ER 25 AX u-tec	EK	1:1
8 043 65 004	ER 25 AX u-tec	IK 140 bar	1:1
$n_{max} = 6000 \text{ min}^{-1}$			
8 043 64 008	ER 16 AX u-tec	EK	1:2
8 043 64 009	ER 16 AX u-tec	IK 140 bar	1:2
$n_{max} = 12000 \text{ min}^{-1}$			

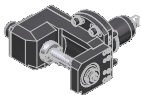

Winkel-Scheibenfräserkopf radial disk mill head

$\pm 10^\circ$ drehbar
 $\pm 10^\circ$ turnable

Mittenmaß / center distance $H=87,5$
auf 0° absteckbar / 0° can be pinned
kein Kühlmittel / no coolant
 $n_{max} = 3000 \text{ min}^{-1}$

8 037 64 023	$\varnothing 16$	2:1
8 037 65 008	$\varnothing 22$	2:1
8 037 64 003	$\varnothing 3/4"$	2:1
8 037 65 019	$\varnothing 1"$	2:1

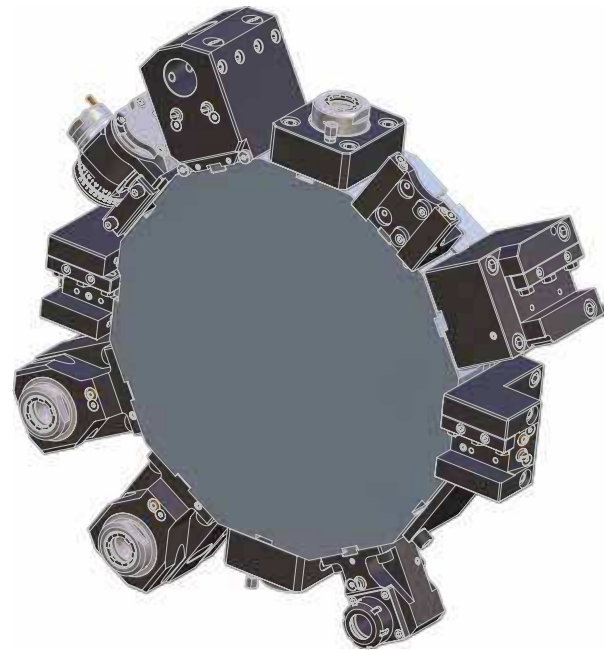

► Weitere Ausführungen auf Anfrage
further versions on request

► Zubehör ZB...*
accessories ZB...*

► easy-quick

► u-tec

feste Werkzeuge
static tool holders

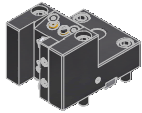

Kombi-Drehstahlhalter
universal turning holder
8 224 15 006 **Vierkant/square 25** EK
8 224 15 016 **Vierkant/square 1"** EK

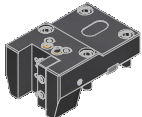

Kombi-Drehstahlhalter
universal turning holder
8 224 15 005 **Vierkant/square 25** EK
8 224 15 015 **Vierkant/square 1"** EK

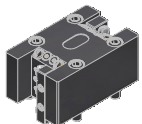

Kombi-Doppel-Drehstahlhalter
combi double turning holder
8 251 15 003 **Vierkant/square 25** EK
8 251 15 008 **Vierkant/square 1"** EK

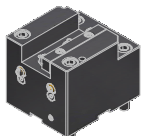

Kombi-Plandrehhalter
combi facing holder
8 244 15 005 **Vierkant/square 25** EK
8 244 15 006 **Vierkant/square 1"** EK



Bohrstangenhalter
boring bar holder
Mittenmaß / center distance H=72
8 240 18 028 **ø32** IK/EK
8 240 19 032 **ø40** IK/EK
8 240 19 044 **ø1,5"** IK/EK
8 240 19 048 **ø2"** IK/EK

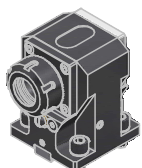

Spannzangenhalter
collet chuck holder
Mittenmaß / center distance H=72
8 240 16 021 **ER 32** IK/EK

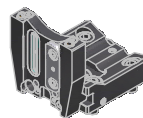
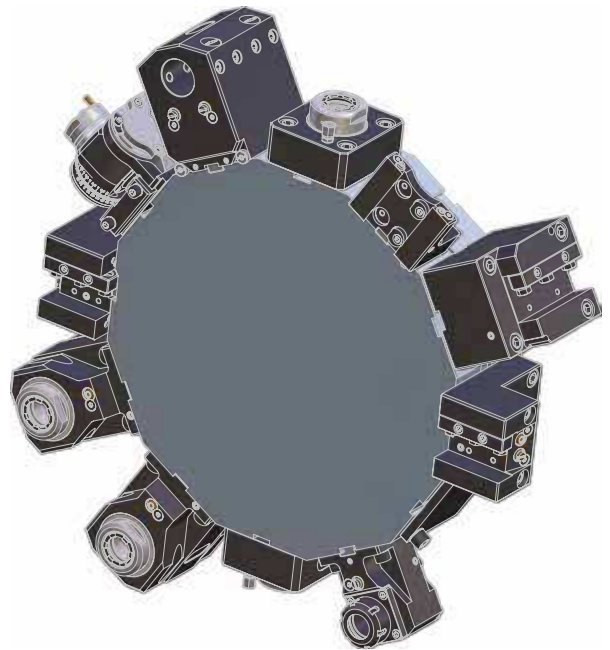

Abstechhalter
cut-off holder
höhenverstellbar / height adjustable
8 320 13 005 **SH 32** IK 70 bar

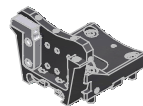

Abstechhalter
cut-off holder **phi HORN phi**
höhenverstellbar / height adjustable
8 320 19 000 **HORN System 845** IK 70 bar

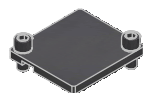

Abdeckblech
cover plate
8 200 03 005

► Weitere Ausführungen auf Anfrage
further versions on request

► Zubehör **ZB...***
accessories **ZB...***

► **easy-quick**

► **u-tec**

► **easy-quick HT Schnellwechselsystem**
easy-quick HT fast change system

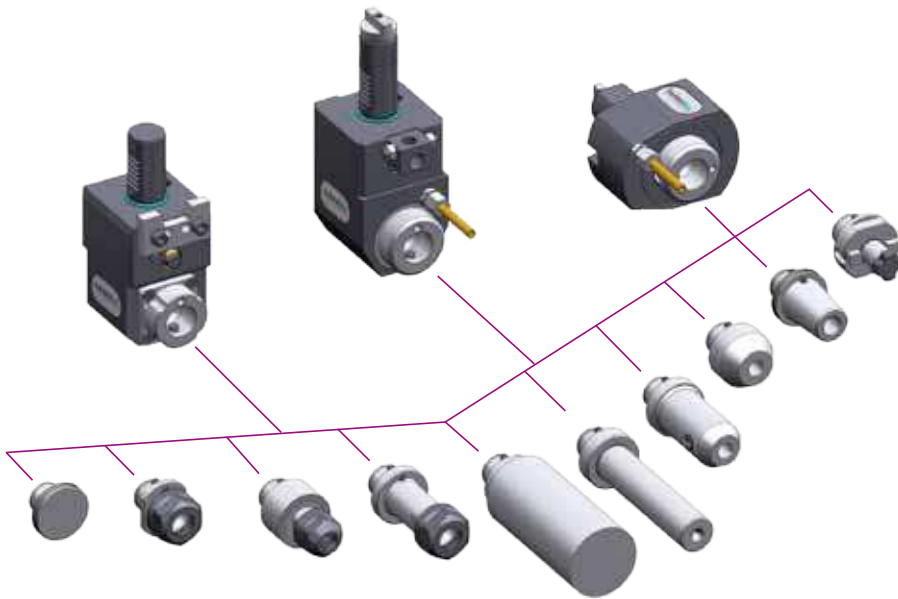

DAS Schnellwechselsystem von heimatec
für angetriebene und feste Werkzeuge

*THE fast change system of heimatec
for driven and static tools*

www.heimatec.de
Produkte / easy-quick

www.heimatec.com
products / easy-quick

► Ausführungen siehe Katalog
versions see catalogue



► **u-tec[®] UT Wechselsystem**
u-tec[®] UT change system

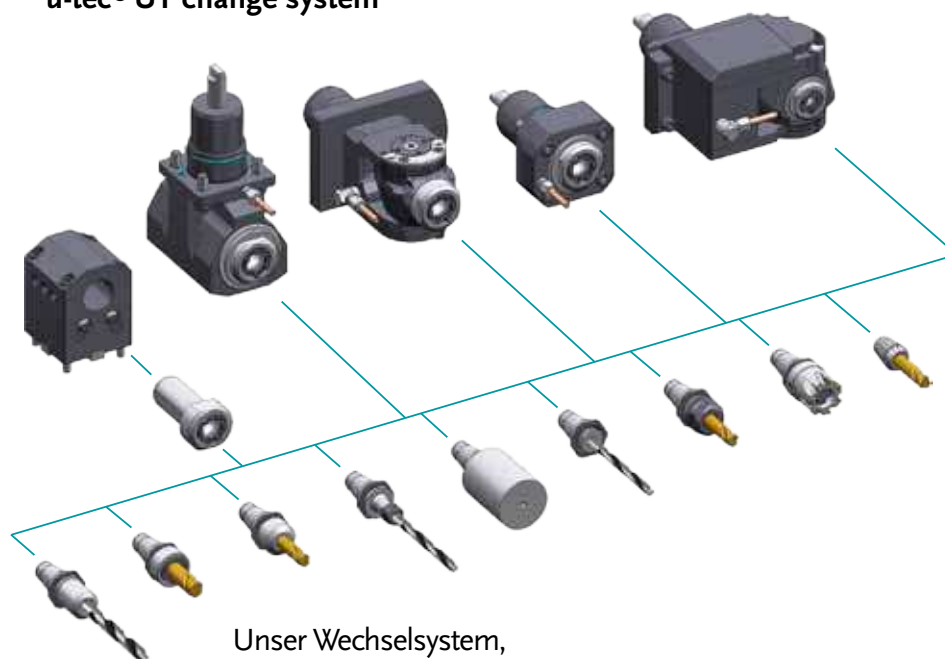

Unser Wechselsystem,
das ALLES möglich macht

Our change system,
that makes EVERYTHING possible

www.heimatec.de
Produkte / u-tec

www.heimatec.com
products / u-tec

► Ausführungen siehe Katalog
versions see catalogue



▶ **Zubehör**
accessories



▶ Ausführungen siehe Katalog
versions see catalogue



www.heimatec.de
Produkte / Zubehör

www.heimatec.com
products / accessories

Notizen
notes

Horizontal lines for taking notes.

heimatec®

- heimatec®-Niederlassungen
heimatec® overseas branches
- unsere weltweiten Vertretungen
global representations of heimatec®

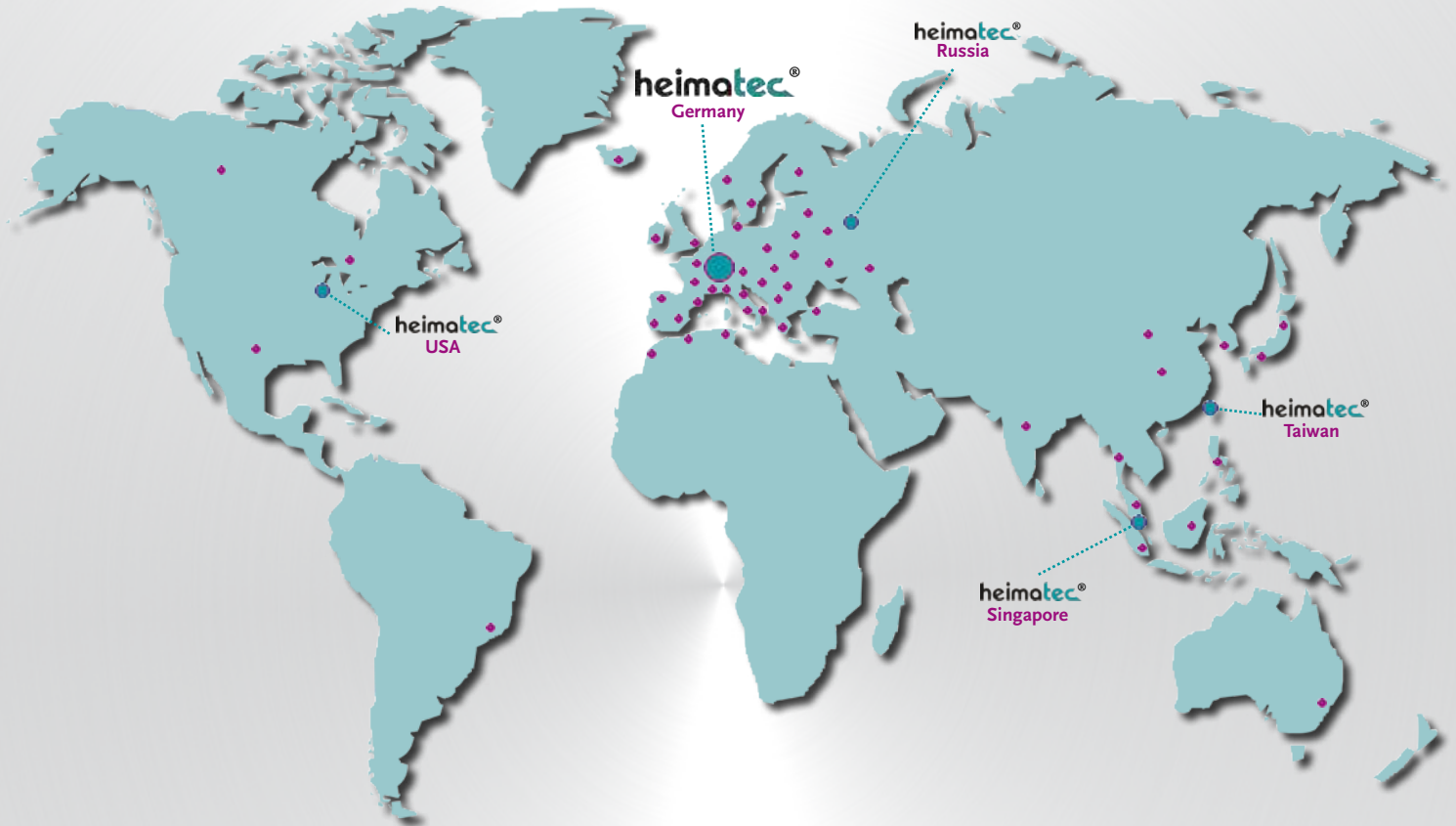

Hauptsitz/headquarters

heimatec® GmbH
Präzisionswerkzeuge
Carl-Benz-Straße 4
D- 77871 Renchen
Postfach 11 36
D- 77867 Renchen
Tel.: +49 (78 43) 94 66 0
Fax: +49 (78 43) 94 66 66
heimatec.de
info@heimatec.de

heimatec® Inc.
USA
usa.heimatec.com
USA@heimatec.com

heimatec®-Ost, JSC
Russia
ru.heimatec.com
Russia@heimatec.com

heimatec® Ltd.
Taiwan
tw.heimatec.com
Taiwan@heimatec.com

heimatec®
Singapore
sg.heimatec.com
Singapore@heimatec.com



Werkzeugkatalog

tool catalogue

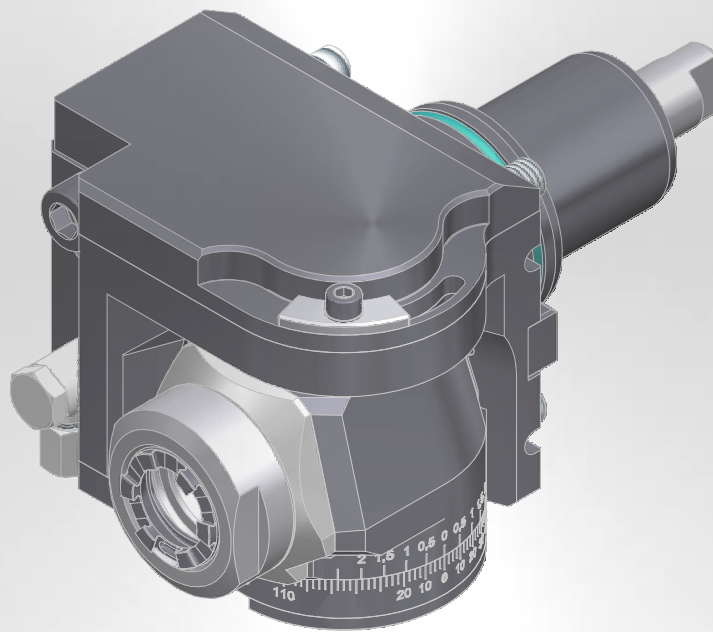

HYUNDAI WIA

LM 1600 TT

LM 1800 TT



Hinweis zu den AGBs:

Diese finden Sie in unserem Internetauftritt unter

www.heimatec.de

Home/Impressum/AGB

Terms and conditions:

You will find them on our website

www.heimatec.com

Home/Imprint/Terms and Conditions

Das Katalog-Werk einschließlich aller seiner Teile ist urheberrechtlich geschützt. Jede Verwertung außerhalb der engen Grenzen des Urheberrechtsgesetzes ist ohne Zustimmung der Rechteeinhaber unzulässig und strafbar. Das gilt insbesondere für Vervielfältigungen, Übersetzungen, Mikroverfilmungen und die Einspeicherung und Verarbeitung in elektronischen Systemen.

heimatec® GmbH behält sich Änderungen technischer Art jederzeit ohne Vorankündigung vor. Dies gilt insbesondere bei Anpassungen an neue oder geänderte internationale Normen oder bei Weiterentwicklungen unserer Produkte oder Herstellungsprozesse.

This catalogue, including all its parts, is protected by copyright. Each use outside the restricted limitations of the Copyright Act is inadmissible and liable to prosecution without the consent of heimatec. This is particularly valid for duplication, translation, microfilming and feeding and processing in electronic systems.

heimatec® GmbH reserves the right of technical changes everytime without advance notice, which is particularly valid for adaptions to new or changed international standards, or to developments of our products or manufacturing processes.

angetriebene Werkzeuge driven tools



Axial-Bohr- und Fräskopf axial drilling and milling head

$n_{max} = 6000 \text{ min}^{-1}$

8 010 55 039	ER 25 AX u-tec	EK	1:1
8 010 55 038	ER 25 AX u-tec	IK 25 bar	1:1
8 010 55 057	ER 25 AX u-tec	IK 70 bar	1:1
8 010 56 039	ER 32 AX u-tec	EK	1:1
8 010 56 040	ER 32 AX u-tec	IK 25 bar	1:1
8 010 56 089	ER 32 AX u-tec	IK 70 bar	1:1
8 010 56 085	easy-quick HT 4	EK	1:1
8 010 56 086	easy-quick HT 4	IK 25 bar	1:1
8 010 56 087	easy-quick HT 4	IK 70 bar	1:1



Axial-Bohr- und Fräskopf kurze Ausführung axial drilling and milling head short version

$n_{max} = 6000 \text{ min}^{-1}$

8 010 56 034	easy-quick HT 4	EK	1:1
8 010 56 035	easy-quick HT 4	IK 25 bar	1:1



Axial-Bohr- und Fräskopf axial drilling and milling head

$n_{max} = 24000 \text{ min}^{-1}$

8 013 54 008	ER 16 AX u-tec	EK	1:4
8 013 54 009	ER 16 AX u-tec	IK 70 bar	1:4



Axial-Bohr- und Fräskopf axial drilling and milling head

$n_{max} = 6000 \text{ min}^{-1}$

8 011 55 012	Kombidom/universal arbor 22	EK	1:1
8 011 55 017	Kombidom/universal arbor 1"	EK	1:1



Axial-Bohr- und Fräskopf axial drilling and milling head

Achsversatz / offset A=42

8 019 54 022	ER 20 AX u-tec	EK	1:1
8 019 54 023	ER 20 AX u-tec	IK 140 bar	1:1
$n_{max} = 6000 \text{ min}^{-1}$			
8 019 54 024	ER 20 AX u-tec	EK	1:2
8 019 54 025	ER 20 AX u-tec	IK 140 bar	1:2
$n_{max} = 12000 \text{ min}^{-1}$			
8 019 54 026	ER 20 AX u-tec	EK	1:3
8 019 54 027	ER 20 AX u-tec	IK 140 bar	1:3
$n_{max} = 18000 \text{ min}^{-1}$			

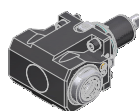
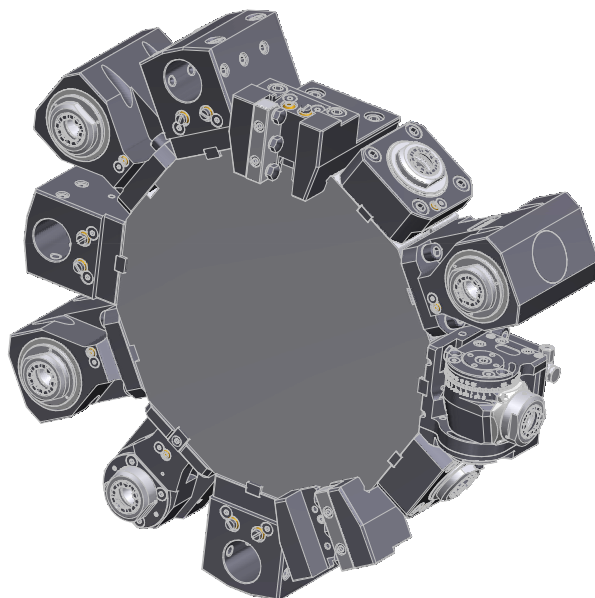

Winkel-Bohr- und Fräskopf radial drilling and milling head

Mittenmaß / center distance H=85

$n_{max} = 6000 \text{ min}^{-1}$

8 030 55 093	ER 25 AX u-tec	EK	1:1
8 030 55 098	ER 25 AX u-tec	IK 140 bar	1:1
8 030 56 099	easy-quick HT 4	EK	1:1
8 030 56 150	easy-quick HT 4	IK 140 bar	1:1

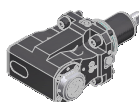

Axial-Bohr- und Fräskopf axial drilling and milling head

Mittenmaß / center distance H=80

8 030 55 068	ER 25 AX u-tec	EK	1:2
8 030 55 066	ER 25 AX u-tec	IK 140 bar	1:2
$n_{max} = 12000 \text{ min}^{-1}$			
8 030 55 069	ER 25 AX u-tec	EK	1:3
8 030 55 067	ER 25 AX u-tec	IK 140 bar	1:3
$n_{max} = 18000 \text{ min}^{-1}$			

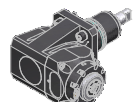

Winkel-Bohr- und Fräskopf radial drilling and milling head

Mittenmaß / center distance H=85

$n_{max} = 24000 \text{ min}^{-1}$

8 030 54 057	ER 16 AX u-tec	EK	1:4
8 030 54 058	ER 16 AX u-tec	IK 70 bar	1:4

► Weitere Ausführungen auf Anfrage
further versions on request

► Zubehör ZB...*
accessories ZB...*

► easy-quick



► u-tec



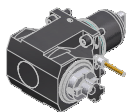

Winkel-Bohr- und Fräskopf radial drilling and milling head

Mittenmaß / center distance $H=85$
 $n_{max} = 6000 \text{ min}^{-1}$

8 031 55 025	Kombidorn/universal arbor 22	EK	1:1
8 031 55 026	Kombidorn/universal arbor 1"	EK	1:1



Winkel-Bohr- und Fräskopf radial drilling and milling head

Mittenmaß / center distance $H=85$
doppelspindlig / double spindle
 $n_{max} = 6000 \text{ min}^{-1}$

8 039 55 026	ER 25 AX u-tec	EK	1:1
8 039 56 028	easy-quick HT 4	EK	1:1

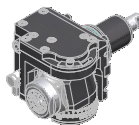

Schwenkkopf universal head

Mittenmaß / center distance $H=50$
Achsversatz / offset $A=35$

8 043 55 005	ER 25 AX u-tec	EK	1:1
8 043 55 009	ER 25 AX u-tec	IK 25 bar	1:1
	$n_{max} = 6000 \text{ min}^{-1}$		
8 043 54 013	ER 16 AX u-tec	EK	1:2
8 043 54 014	ER 16 AX u-tec	IK 25 bar	1:2
	$n_{max} = 12000 \text{ min}^{-1}$		



Winkel-Scheibenfräserkopf radial disk mill head

$\pm 30^\circ$ drehbar
 $\pm 30^\circ$ turnable

Mittenmaß / center distance $H=78$
auf 0° absteckbar / 0° can be pinned
kein Kühlmittel / no coolant
 $n_{max} = 4000 \text{ min}^{-1}$

8 037 54 013	$\varnothing 16$	2:1
8 037 54 014	$\varnothing 5/8"$	2:1

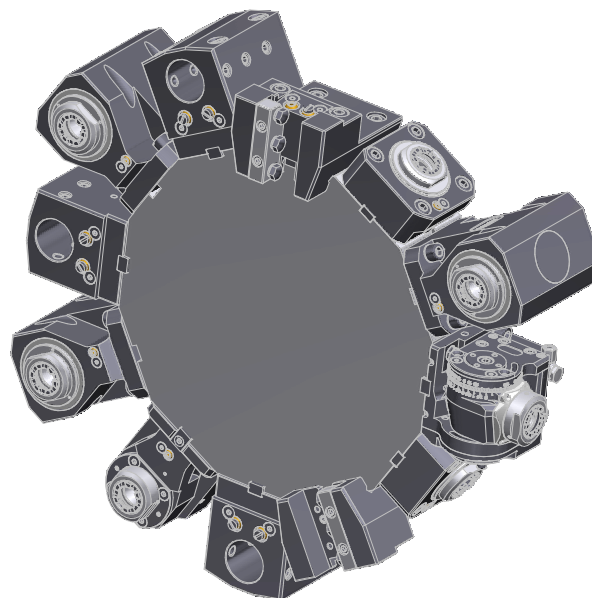

► Weitere Ausführungen auf Anfrage
further versions on request

► Zubehör ZB...*
accessories ZB...*



► easy-quick



► u-tec



feste Werkzeuge
static tool holders

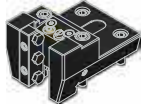

Kombi-Drehstahlhalter
universal turning holder
8 224 05 003 **Vierkant/square 25** EK
8 224 05 005 **Vierkant/square 1"** EK

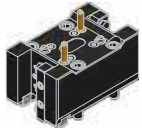

Kombi-Doppel-Drehstahlhalter
combi double turning holder
8 251 05 001 **Vierkant/square 25** EK
8 251 05 003 **Vierkant/square 1"** EK



Kombi-Plandrehhalter
combi facing holder
8 244 05 003 **Vierkant/square 25** EK
8 244 05 006 **Vierkant/square 1"** EK



Bohrstangenhalter
boring bar holder
Mittenmaß / center distance H=95
8 240 08 026 **ø32** IK/EK
8 240 08 027 **ø1 1/4"** IK/EK

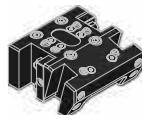

Kombi-Mehrfachdrehhalter
combi multiple holder
für 1/2 Stationen-Takt / for 1/2 station indexing
8 251 04 022 **6x Vierkant/square 20** EK
8 251 04 021 **6x Vierkant/square 3/4"** EK

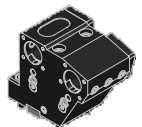

Mehrfach-Bohrstangenhalter
multiple boring bar holder
für 1/2 Stationen-Takt / for 1/2 station indexing
Mittenmaß / center distance H=47,5/82,5
8 253 07 025 **3x ø25** IK/EK
8 253 07 024 **3x ø1"** IK/EK

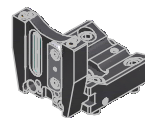
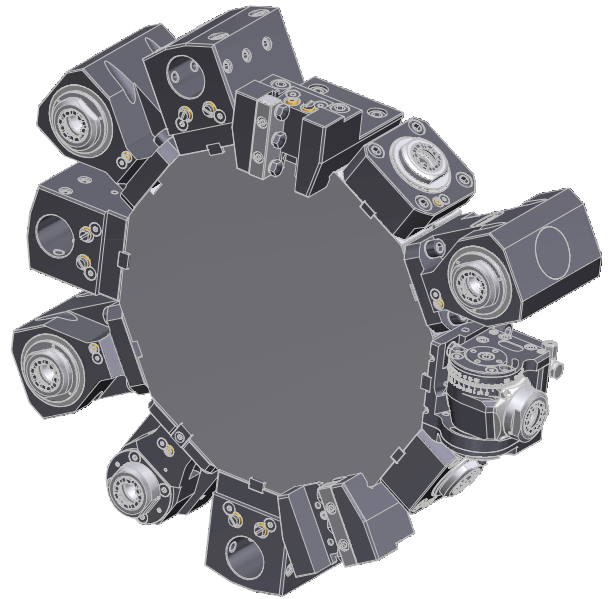

Abstechhalter
cut-off holder
höhenverstellbar / height adjustable
8 320 03 008 **SH 32** IK 70 bar

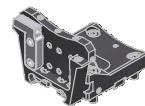

Abstechhalter
cut-off holder **phi HORN phi**
höhenverstellbar / height adjustable
8 320 09 001 **HORN System 845** IK 70 bar

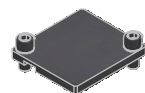

Abdeckblech
cover plate
8 200 52 001

► Weitere Ausführungen auf Anfrage
further versions on request

► Zubehör **ZB...***
accessories **ZB...***

► **easy-quick**

► **u-tec**

► **easy-quick HT Schnellwechselsystem**
easy-quick HT fast change system

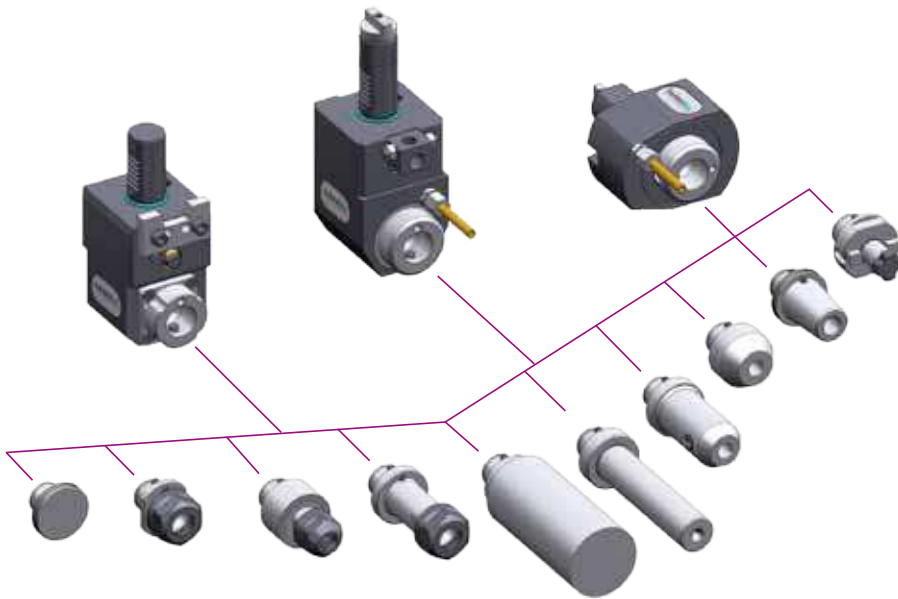

DAS Schnellwechselsystem von heimatec
für angetriebene und feste Werkzeuge

*THE fast change system of heimatec
for driven and static tools*

www.heimatec.de
Produkte / easy-quick

www.heimatec.com
products / easy-quick

► Ausführungen siehe Katalog
versions see catalogue



► **u-tec[®] UT Wechselsystem**
u-tec[®] UT change system

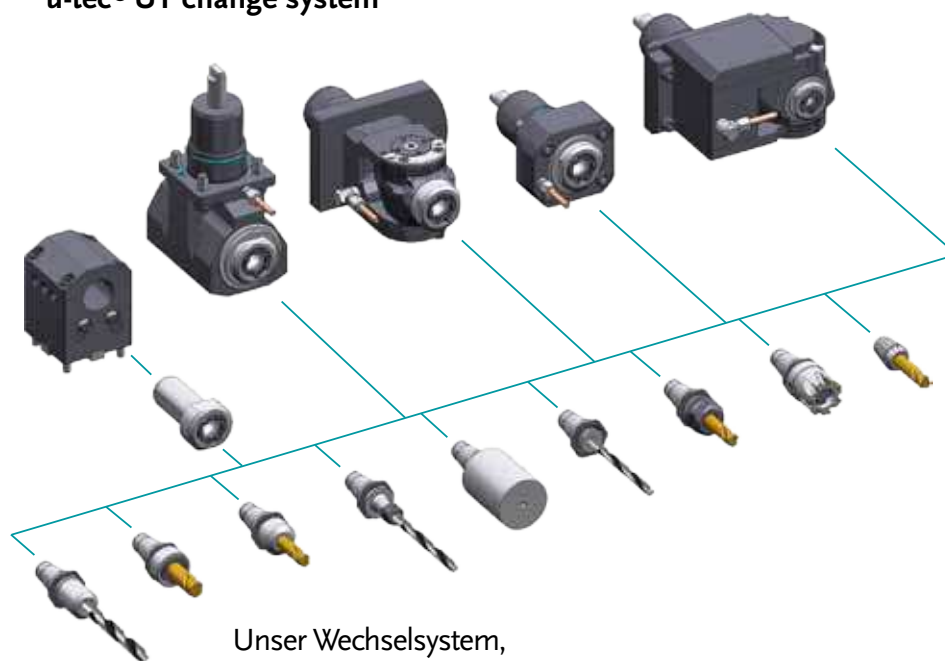

Unser Wechselsystem,
das ALLES möglich macht

Our change system,
that makes EVERYTHING possible

www.heimatec.de
Produkte / u-tec

www.heimatec.com
products / u-tec

► Ausführungen siehe Katalog
versions see catalogue



heimatec®

- heimatec®-Niederlassungen
heimatec® overseas branches
- unsere weltweiten Vertretungen
global representations of heimatec®

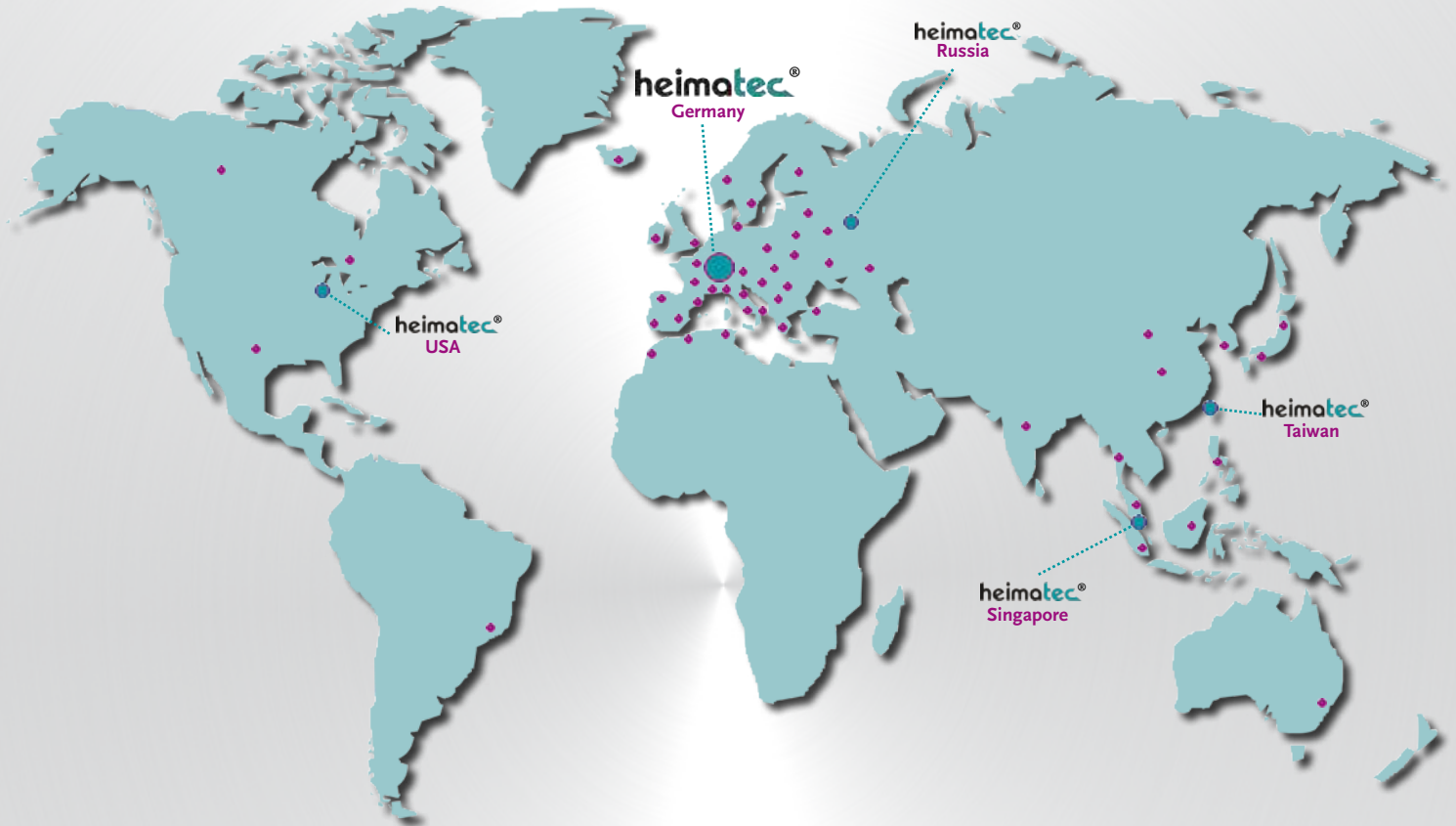

Hauptsitz/headquarters

heimatec® GmbH
Präzisionswerkzeuge
Carl-Benz-Straße 4
D- 77871 Renchen
Postfach 11 36
D- 77867 Renchen
Tel.: +49 (78 43) 94 66 0
Fax: +49 (78 43) 94 66 66
heimatec.de
info@heimatec.de

heimatec® Inc.
USA
usa.heimatec.com
USA@heimatec.com

heimatec®-Ost, JSC
Russia
ru.heimatec.com
Russia@heimatec.com

heimatec® Ltd.
Taiwan
tw.heimatec.com
Taiwan@heimatec.com

heimatec®
Singapore
sg.heimatec.com
Singapore@heimatec.com



Werkzeugkatalog

tool catalogue

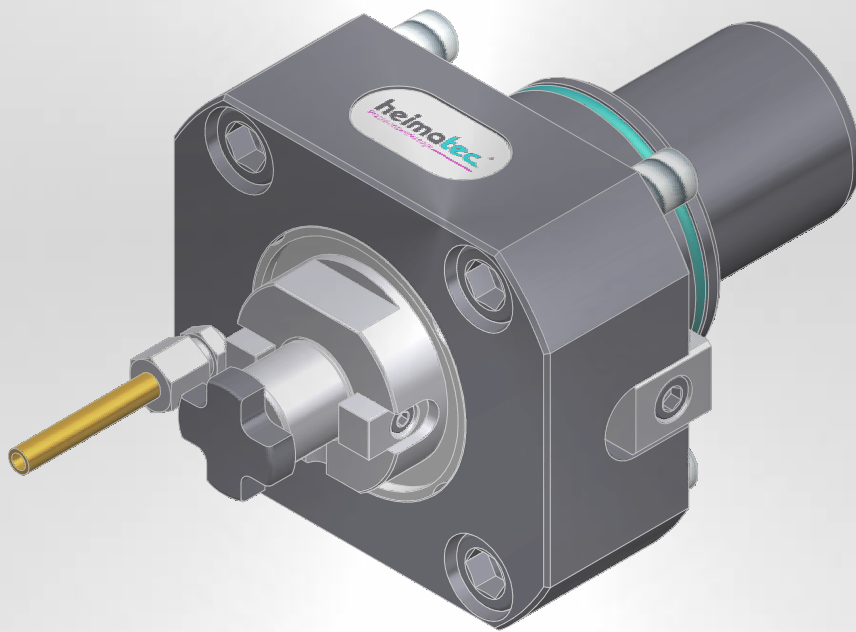

HYUNDAI WIA

LM 2000 TT

LM 2500 TT



Hinweis zu den AGBs:

Diese finden Sie in unserem Internetauftritt unter

www.heimatec.de

Home/Impressum/AGB

Terms and conditions:

You will find them on our website

www.heimatec.com

Home/Imprint/Terms and Conditions

Das Katalog-Werk einschließlich aller seiner Teile ist urheberrechtlich geschützt. Jede Verwertung außerhalb der engen Grenzen des Urheberrechtsgesetzes ist ohne Zustimmung der Rechteeinhaber unzulässig und strafbar. Das gilt insbesondere für Vervielfältigungen, Übersetzungen, Mikroverfilmungen und die Einspeicherung und Verarbeitung in elektronischen Systemen.

heimatec® GmbH behält sich Änderungen technischer Art jederzeit ohne Vorankündigung vor. Dies gilt insbesondere bei Anpassungen an neue oder geänderte internationale Normen oder bei Weiterentwicklungen unserer Produkte oder Herstellungsprozesse.

This catalogue, including all its parts, is protected by copyright. Each use outside the restricted limitations of the Copyright Act is inadmissible and liable to prosecution without the consent of heimatec. This is particularly valid for duplication, translation, microfilming and feeding and processing in electronic systems.

heimatec® GmbH reserves the right of technical changes everytime without advance notice, which is particularly valid for adaptations to new or changed international standards, or to developments of our products or manufacturing processes.

angetriebene Werkzeuge

driven tools



Axial-Bohr- und Fräskopf

axial drilling and milling head

$n_{max} = 6000 \text{ min}^{-1}$

8 010 66 079	ER 32 AX u-tec	EK	1:1
8 010 66 081	ER 32 AX u-tec	IK 25 bar	1:1
8 010 66 046	ER 32 AX u-tec	IK 70 bar	1:1
8 010 67 025	easy-quick HT 5	EK	1:1
8 010 67 026	easy-quick HT 5	IK 25 bar	1:1
8 010 67 060	easy-quick HT 5	IK 70 bar	1:1



Axial-Bohr- und Fräskopf

axial drilling and milling head

$n_{max} = 24000 \text{ min}^{-1}$

8 013 64 008	ER 16 AX u-tec	EK	1:4
8 013 64 009	ER 16 AX u-tec	IK 70 bar	1:4



Axial-Bohr- und Fräskopf

axial drilling and milling head

$n_{max} = 6000 \text{ min}^{-1}$

8 011 65 014	Kombidorn/universal arbor 22	EK	1:1
8 011 65 011	Kombidorn/universal arbor 1"	EK	1:1



Axial-Bohr- und Fräskopf

axial drilling and milling head

Achsversatz / offset A=50

8 019 65 021	ER 25 AX u-tec	EK	1:1
8 019 65 022	ER 25 AX u-tec	IK 140 bar	1:1
$n_{max} = 6000 \text{ min}^{-1}$			
8 019 65 004	ER 25 AX u-tec	EK	1:2
8 019 65 027	ER 25 AX u-tec	IK 140 bar	1:2
$n_{max} = 12000 \text{ min}^{-1}$			
8 019 65 023	ER 25 AX u-tec	EK	2:1
8 019 65 024	ER 25 AX u-tec	IK 140 bar	2:1
$n_{max} = 3000 \text{ min}^{-1}$			
8 019 65 025	ER 25 AX u-tec	EK	1:3
8 019 65 026	ER 25 AX u-tec	IK 140 bar	1:3
$n_{max} = 15000 \text{ min}^{-1}$			

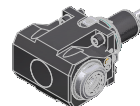
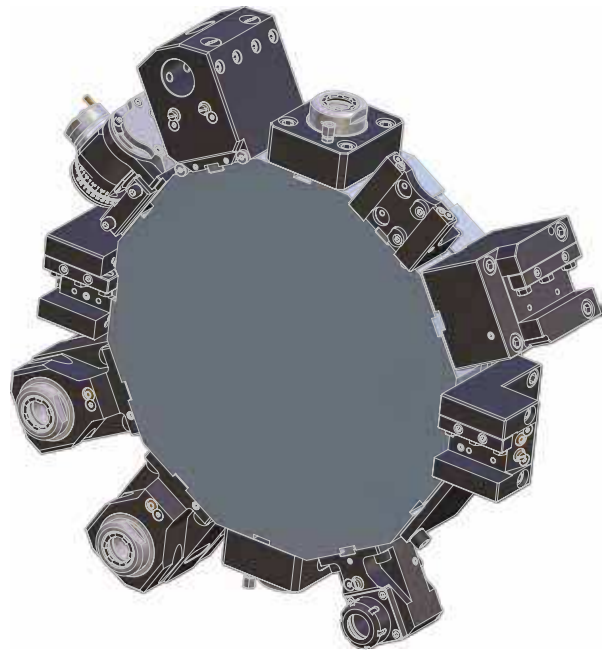

Winkel-Bohr- und Fräskopf

radial drilling and milling head

Mittenmaß / center distance H=100
 $n_{max} = 6000 \text{ min}^{-1}$

8 030 66 045	ER 32 AX u-tec	EK	1:1
8 030 66 102	ER 32 AX u-tec	IK 140 bar	1:1
8 030 67 059	easy-quick HT 5	EK	1:1
8 030 67 073	easy-quick HT 5	IK 140 bar	1:1

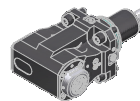

Axial-Bohr- und Fräskopf

axial drilling and milling head

Mittenmaß / center distance H=95

8 030 65 055	ER 25 AX u-tec	EK	1:2
8 030 65 063	ER 25 AX u-tec	IK 140 bar	1:2
$n_{max} = 12000 \text{ min}^{-1}$			
8 030 65 064	ER 25 AX u-tec	EK	1:3
8 030 65 065	ER 25 AX u-tec	IK 140 bar	1:3
$n_{max} = 18000 \text{ min}^{-1}$			

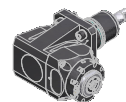

Winkel-Bohr- und Fräskopf

radial drilling and milling head

Mittenmaß / center distance H=100
 $n_{max} = 24000 \text{ min}^{-1}$

8 030 64 024	ER 16 AX u-tec	EK	1:4
8 030 64 025	ER 16 AX u-tec	IK 140 bar	1:4

► Weitere Ausführungen auf Anfrage
further versions on request

► Zubehör ZB...*
accessories ZB...*

► easy-quick



► u-tec

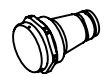

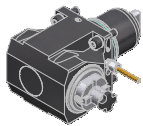

Winkel-Bohr- und Fräskopf radial drilling and milling head

Mittenmaß / center distance $H=100$
 $n_{max} = 6000 \text{ min}^{-1}$

8 031 65 016	Kombidorn/universal arbor 22	EK	1:1
8 031 65 011	Kombidorn/universal arbor 1"	EK	1:1



Winkel-Bohr- und Fräskopf radial drilling and milling head

Mittenmaß / center distance $H=110$
doppelspindlig / double spindle
 $n_{max} = 6000 \text{ min}^{-1}$

8 039 66 034	ER 32 AX u-tec	EK	1:1
8 039 67 012	easy-quick HT 5	EK	1:1



Schwenkkopf universal head

Mittenmaß / center distance $H=69$
Achsversatz / offset $A=60$

8 043 65 000	ER 25 AX u-tec	EK	1:1
8 043 65 004	ER 25 AX u-tec	IK 140 bar	1:1
$n_{max} = 6000 \text{ min}^{-1}$			
8 043 64 008	ER 16 AX u-tec	EK	1:2
8 043 64 009	ER 16 AX u-tec	IK 140 bar	1:2
$n_{max} = 12000 \text{ min}^{-1}$			

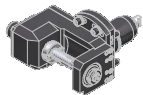

Winkel-Scheibenfräserkopf radial disk mill head

$\pm 10^\circ$ drehbar
 $\pm 10^\circ$ turnable

Mittenmaß / center distance $H=87,5$
auf 0° absteckbar / 0° can be pinned
kein Kühlmittel / no coolant
 $n_{max} = 3000 \text{ min}^{-1}$

8 037 64 023	$\varnothing 16$	2:1
8 037 65 008	$\varnothing 22$	2:1
8 037 64 003	$\varnothing 3/4"$	2:1
8 037 65 019	$\varnothing 1"$	2:1

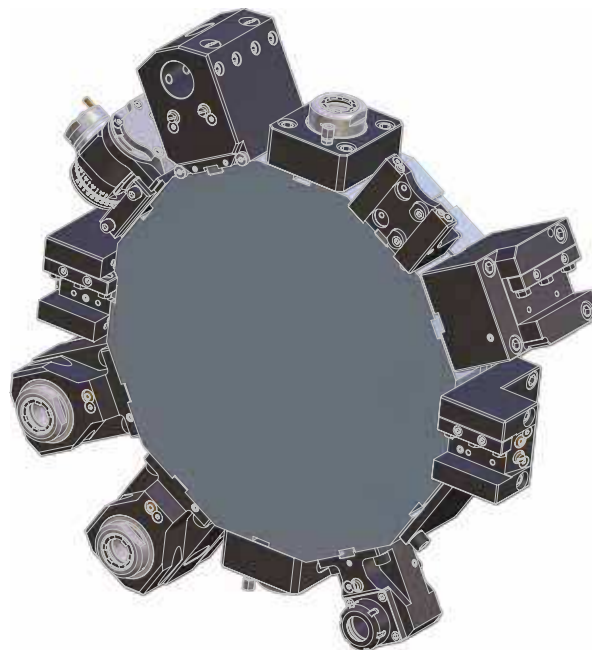

► Weitere Ausführungen auf Anfrage
further versions on request

► Zubehör ZB...*
accessories ZB...*



► easy-quick



► u-tec



feste Werkzeuge static tool holders

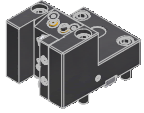

Kombi-Drehstahlhalter
universal turning holder

8 224 15 006 **Vierkant/square 25** EK
8 224 15 016 **Vierkant/square 1"** EK

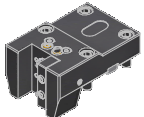

Kombi-Drehstahlhalter
universal turning holder

8 224 15 005 **Vierkant/square 25** EK
8 224 15 015 **Vierkant/square 1"** EK

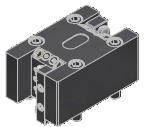

Kombi-Doppel-Drehstahlhalter
combi double turning holder

8 251 15 003 **Vierkant/square 25** EK
8 251 15 008 **Vierkant/square 1"** EK

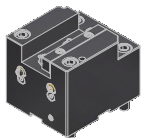

Kombi-Plandrehhalter
combi facing holder

8 244 15 005 **Vierkant/square 25** EK
8 244 15 006 **Vierkant/square 1"** EK



Bohrstangenhalter
boring bar holder

Mittenmaß / center distance H=100

8 240 18 049 **ø32** IK/EK
8 240 19 043 **ø40** IK/EK
8 240 19 051 **ø50** IK/EK
8 240 17 063 **ø1 1/4"** IK/EK
8 240 19 058 **ø1 1/2"** IK/EK
8 240 19 062 **ø2"** IK/EK

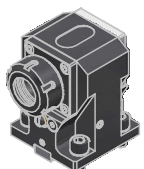

Spannzangenhalter
collet chuck holder

Mittenmaß / center distance H=100

8 240 16 026 **ER 32** IK/EK

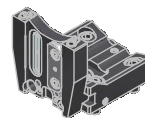
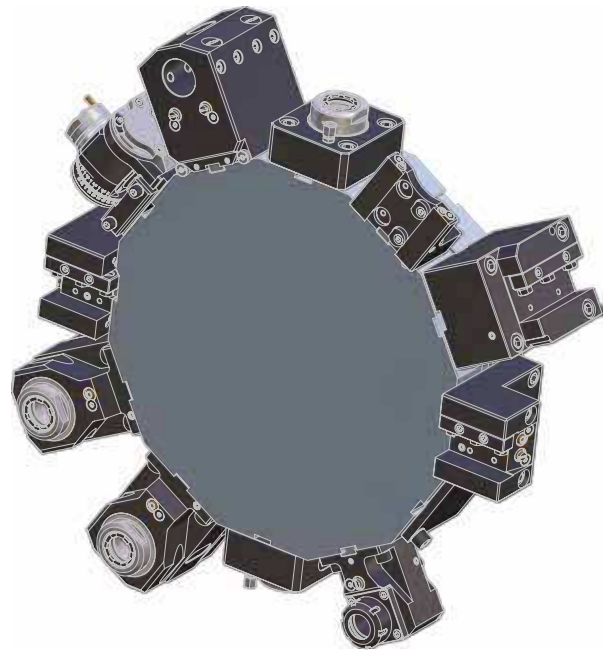

Abstechhalter
cut-off holder

höhenverstellbar / height adjustable

8 320 13 005 **SH 32** IK 70 bar

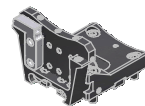

Abstechhalter
cut-off holder

höhenverstellbar / height adjustable

8 320 19 000 **HORN System 845** IK 70 bar

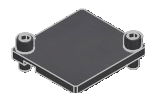

Abdeckblech
cover plate

8 200 03 005

► Weitere Ausführungen auf Anfrage
further versions on request

► Zubehör **ZB...***
accessories **ZB...***

► **easy-quick**

► **u-tec**

► **easy-quick HT Schnellwechselsystem**
easy-quick HT fast change system

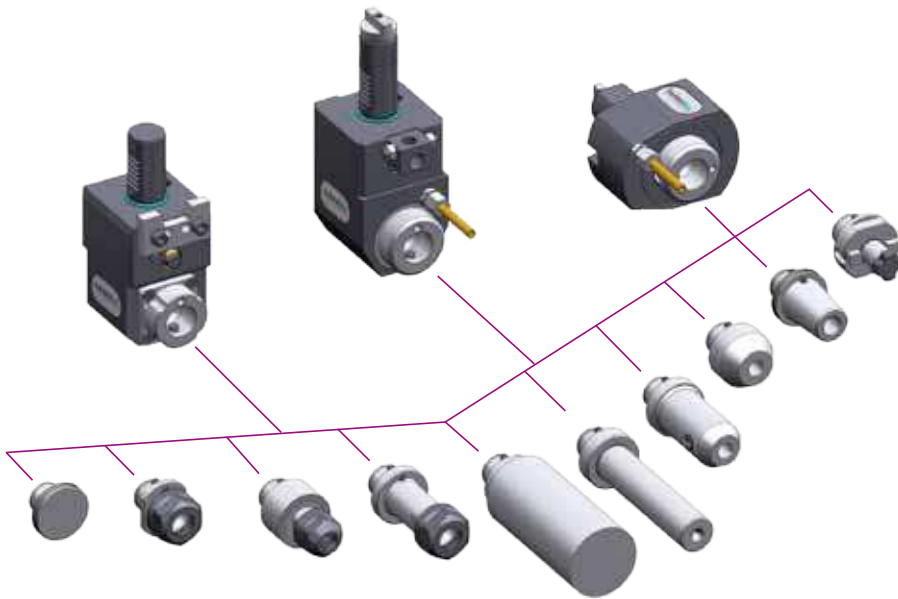

DAS Schnellwechselsystem von heimatec
für angetriebene und feste Werkzeuge

*THE fast change system of heimatec
for driven and static tools*

www.heimatec.de
Produkte / easy-quick

www.heimatec.com
products / easy-quick

► Ausführungen siehe Katalog
versions see catalogue



► **u-tec[®] UT Wechselsystem**
u-tec[®] UT change system

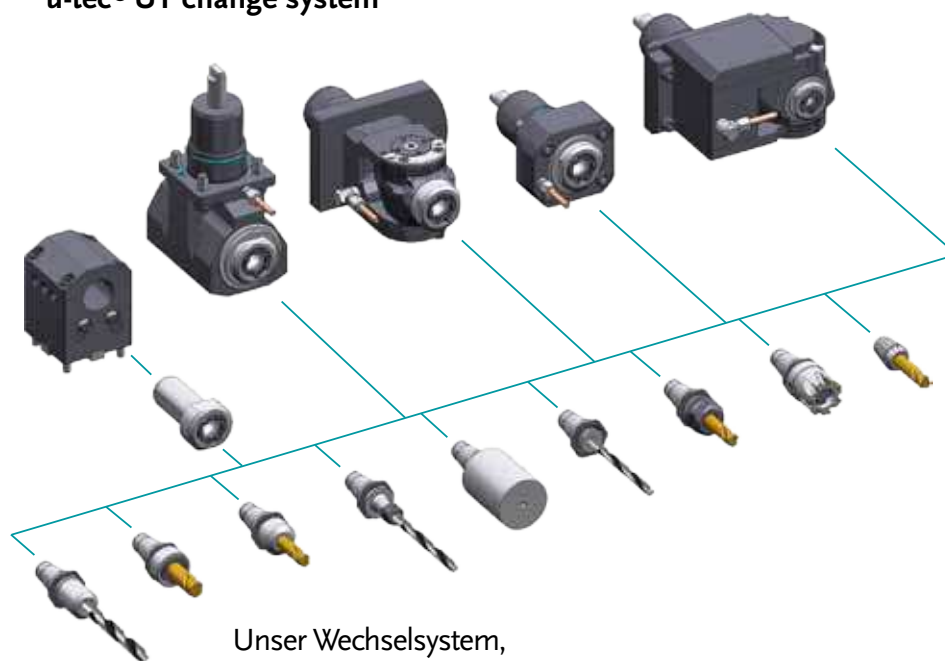

Unser Wechselsystem,
das ALLES möglich macht

Our change system,
that makes EVERYTHING possible

www.heimatec.de
Produkte / u-tec

www.heimatec.com
products / u-tec

► Ausführungen siehe Katalog
versions see catalogue



heimatec®

- heimatec®-Niederlassungen
heimatec® overseas branches
- unsere weltweiten Vertretungen
global representations of heimatec®

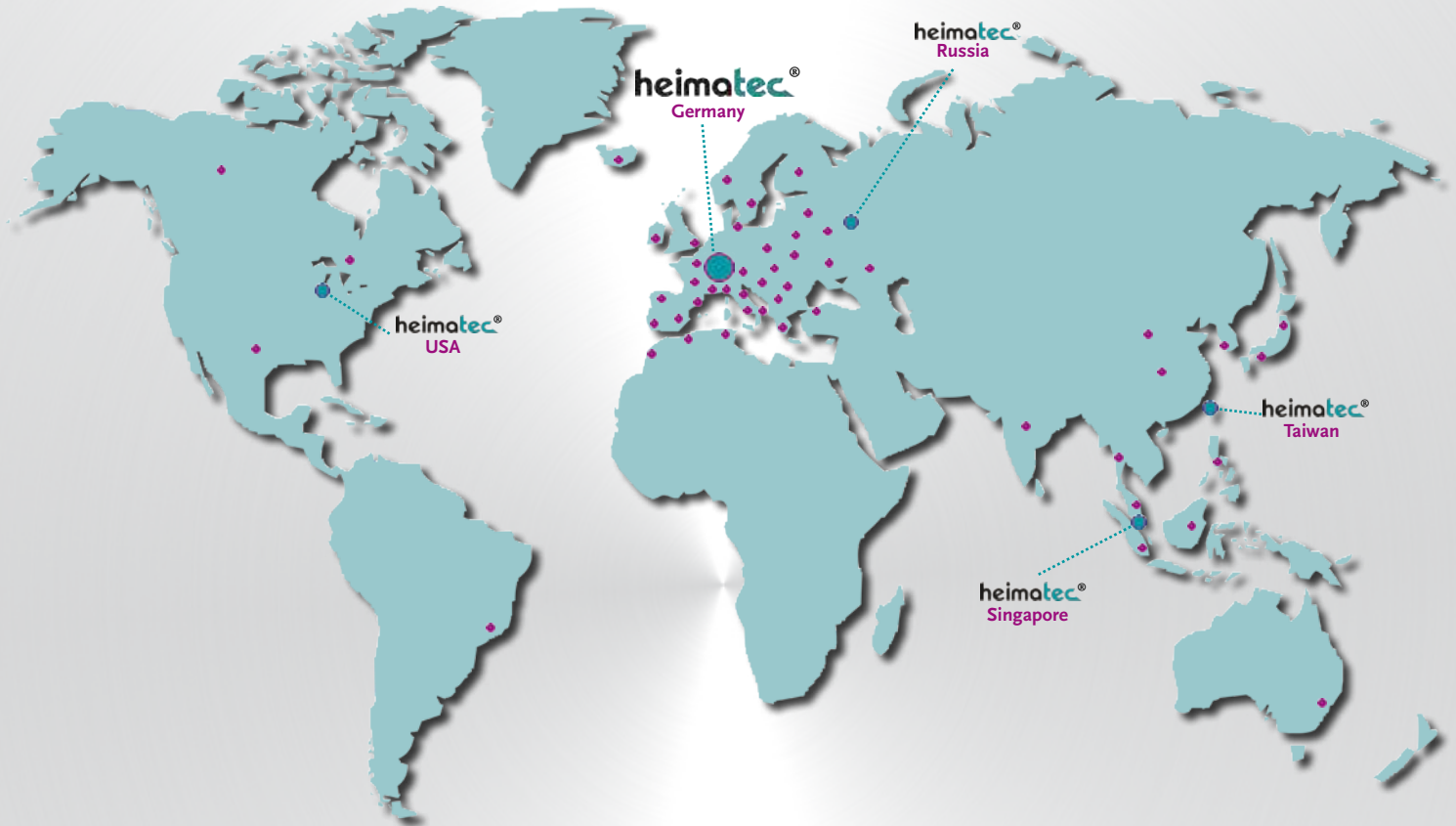

Hauptsitz/headquarters

heimatec® GmbH
Präzisionswerkzeuge
Carl-Benz-Straße 4
D- 77871 Renchen
Postfach 11 36
D- 77867 Renchen
Tel.: +49 (78 43) 94 66 0
Fax: +49 (78 43) 94 66 66
heimatec.de
info@heimatec.de

heimatec® Inc.
USA
usa.heimatec.com
USA@heimatec.com

heimatec®-Ost, JSC
Russia
ru.heimatec.com
Russia@heimatec.com

heimatec® Ltd.
Taiwan
tw.heimatec.com
Taiwan@heimatec.com

heimatec®
Singapore
sg.heimatec.com
Singapore@heimatec.com



Werkzeugkatalog

tool catalogue

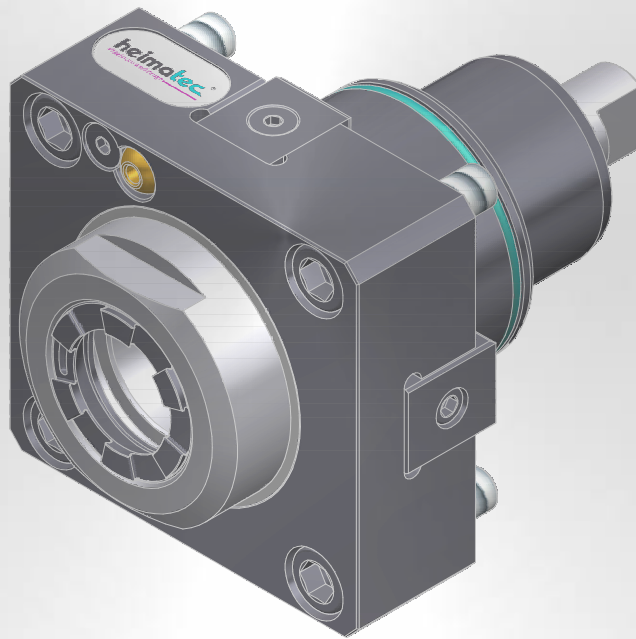

HYUNDAI WIA

LV 500 RM/LM



Hinweis zu den AGBs:

Diese finden Sie in unserem Internetauftritt unter

www.heimatec.de

Home/Impressum/AGB

Terms and conditions:

You will find them on our website

www.heimatec.com

Home/Imprint/Terms and Conditions

Das Katalog-Werk einschließlich aller seiner Teile ist urheberrechtlich geschützt. Jede Verwertung außerhalb der engen Grenzen des Urheberrechtsgesetzes ist ohne Zustimmung der Rechteeinhaber unzulässig und strafbar. Das gilt insbesondere für Vervielfältigungen, Übersetzungen, Mikroverfilmungen und die Einspeicherung und Verarbeitung in elektronischen Systemen.

heimatec® GmbH behält sich Änderungen technischer Art jederzeit ohne Vorankündigung vor. Dies gilt insbesondere bei Anpassungen an neue oder geänderte internationale Normen oder bei Weiterentwicklungen unserer Produkte oder Herstellungsprozesse.

This catalogue, including all its parts, is protected by copyright. Each use outside the restricted limitations of the Copyright Act is inadmissible and liable to prosecution without the consent of heimatec. This is particularly valid for duplication, translation, microfilming and feeding and processing in electronic systems.

heimatec® GmbH reserves the right of technical changes everytime without advance notice, which is particularly valid for adaptions to new or changed international standards, or to developments of our products or manufacturing processes.

angetriebene Werkzeuge
driven tools



Axial-Bohr- und Fräskopf
axial drilling and milling head

$n_{max} = 4000 \text{ min}^{-1}$

8 010 67 059	ER 40 AX u-tec	EK	1:1
8 010 67 039	ER 40 AX u-tec	IK 25 bar	1:1
8 010 67 061	ER 40 AX u-tec	IK 70 bar	1:1
8 010 68 031	easy-quick HT 6	EK	1:1
8 010 68 032	easy-quick HT 6	IK 25 bar	1:1
8 010 68 037	easy-quick HT 6	IK 70 bar	1:1



Axial-Bohr- und Fräskopf
axial drilling and milling head

$n_{max} = 4000 \text{ min}^{-1}$

8 011 65 007	Kombidom/universal arbor 22	EK	1:1
8 011 65 016	Kombidom/universal arbor 1"	EK	1:1



Winkel-Bohr- und Fräskopf
radial drilling and milling head

Mittenmaß / center distance $H=90$
 $n_{max} = 4000 \text{ min}^{-1}$

8 030 67 074	ER 40 AX u-tec	EK	1:1
8 030 67 071	ER 40 AX u-tec	IK 140 bar	1:1
8 030 68 023	easy-quick HT 6	EK	1:1
8 030 68 022	easy-quick HT 6	IK 140 bar	1:1



Winkel-Bohr- und Fräskopf
radial drilling and milling head

Mittenmaß / center distance $H=90$
 $n_{max} = 4000 \text{ min}^{-1}$

8 031 65 020	Kombidom/universal arbor 22	EK	1:1
8 031 65 021	Kombidom/universal arbor 1"	EK	1:1

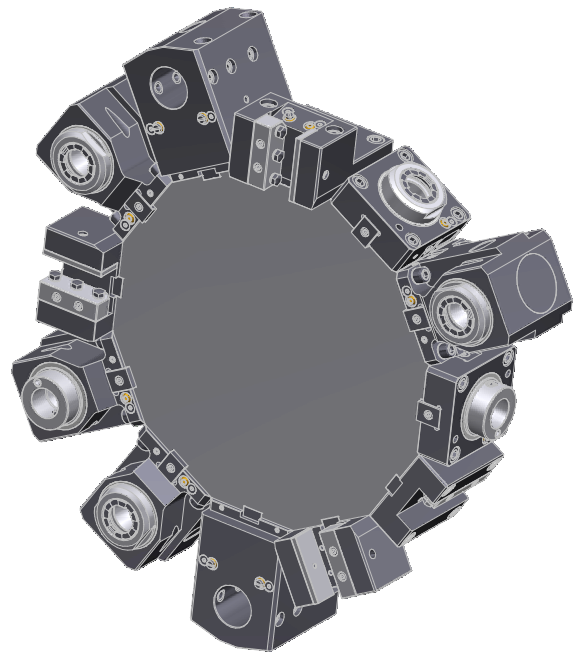

► Weitere Ausführungen auf Anfrage
further versions on request

► Zubehör ZB...*
accessories ZB...*



► easy-quick



► u-tec



feste Werkzeuge
static tool holders

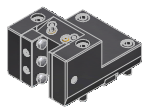

Kombi-Drehstahlhalter
universal turning holder

8 224 26 002	Vierkant/square 32	EK
8 224 26 008	Vierkant/square 1 1/4"	EK

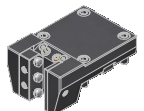

Kombi-Drehstahlhalter
universal turning holder

8 224 26 006	Vierkant/square 32	EK
8 224 26 007	Vierkant/square 1 1/4"	EK

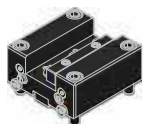

Kombi-Plandrehhalter
combi facing holder

8 244 26 004	Vierkant/square 32	EK
8 244 26 005	Vierkant/square 1 1/4"	EK

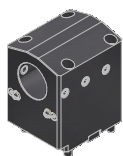

Bohrstangenhalter
boring bar holder

Mittenmaß / center distance H=110

8 240 29 025	ø40	IK/EK
8 240 29 026	ø50	IK/EK
8 240 29 020	ø60	IK/EK
8 240 29 029	ø2"	IK/EK
8 240 29 036	ø2 1/2"	IK/EK

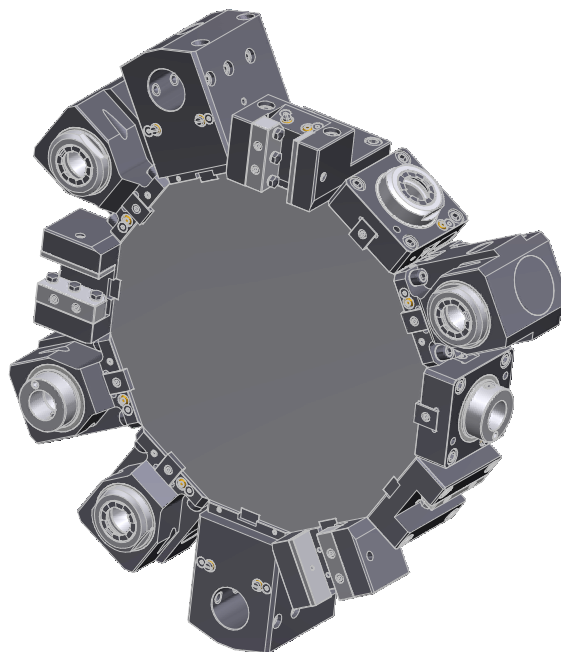

▶ Weitere Ausführungen auf Anfrage
further versions on request

▶ Zubehör ZB...*
accessories ZB...*



▶ easy-quick



▶ u-tec



- ▶ *easy-quick* HT Schnellwechselsystem
easy-quick HT *fast change system*

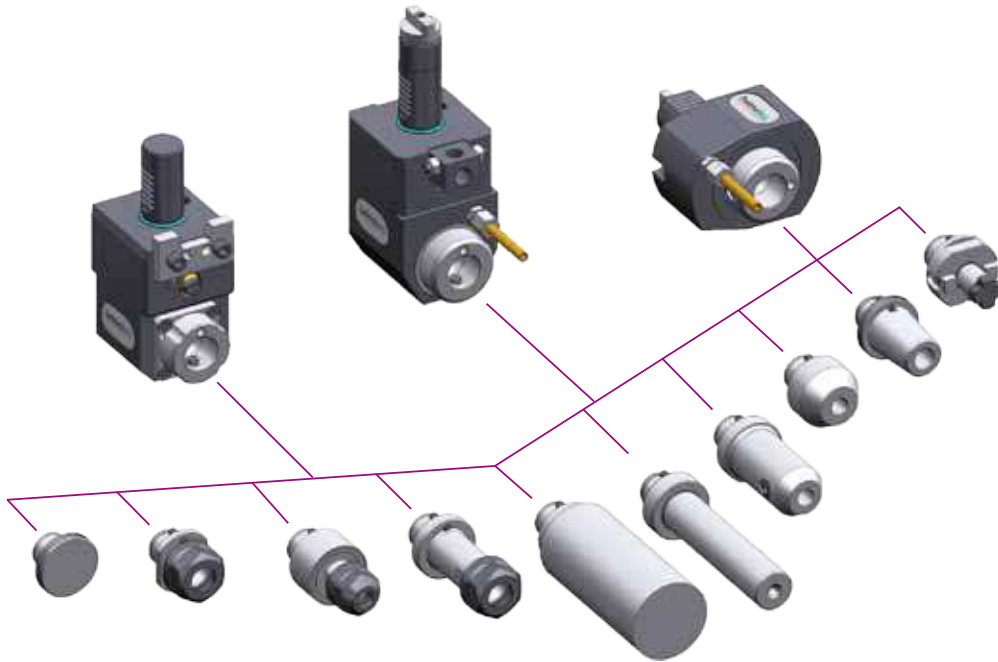

DAS Schnellwechselsystem von heimatec
für angetriebene und feste Werkzeuge

*THE fast change system of heimatec
for driven and static tools*

- ▶ Ausführungen siehe Katalog
versions see catalogue

www.heimatec.de
Produkte / easy-quick

www.heimatec.com
products / easy-quick



► **u-tec[®] UT Wechselsystem**
u-tec[®] UT change system

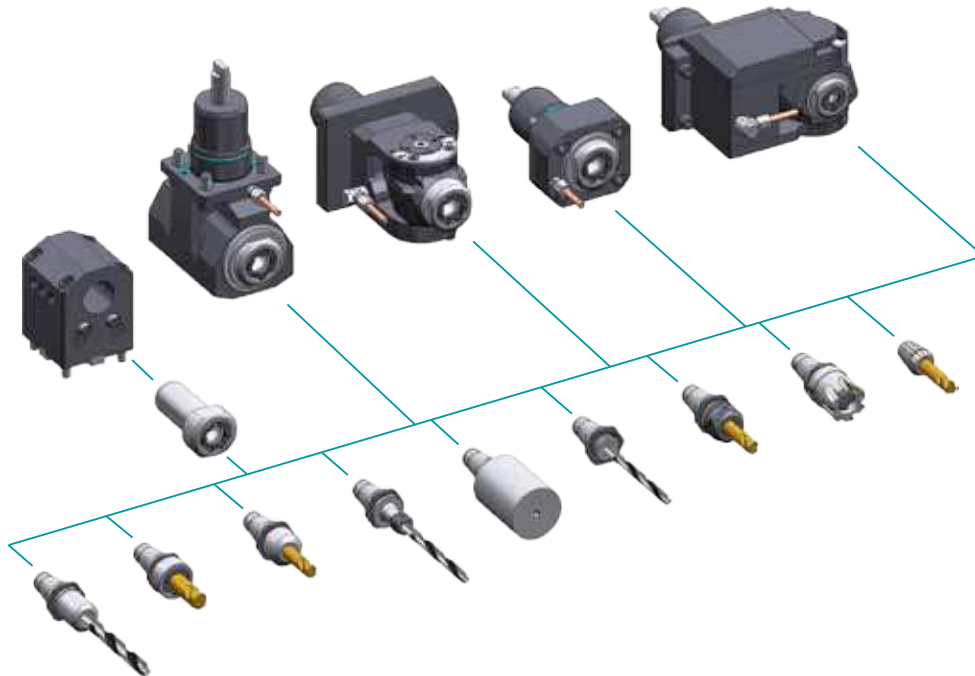

Unser Wechselsystem,
das ALLES möglich macht

Our change system,
that makes EVERYTHING possible

► Ausführungen siehe Katalog
versions see catalogue



www.heimatec.de
Produkte / u-tec

www.heimatec.com
products / u-tec

► **Zubehör**
accessories



► Ausführungen siehe Katalog
versions see catalogue



www.heimatec.de
Produkte / Zubehör

www.heimatec.com
products / accessories

heimatec®

- heimatec®-Niederlassungen
heimatec® overseas branches
- unsere weltweiten Vertretungen
global representations of heimatec®

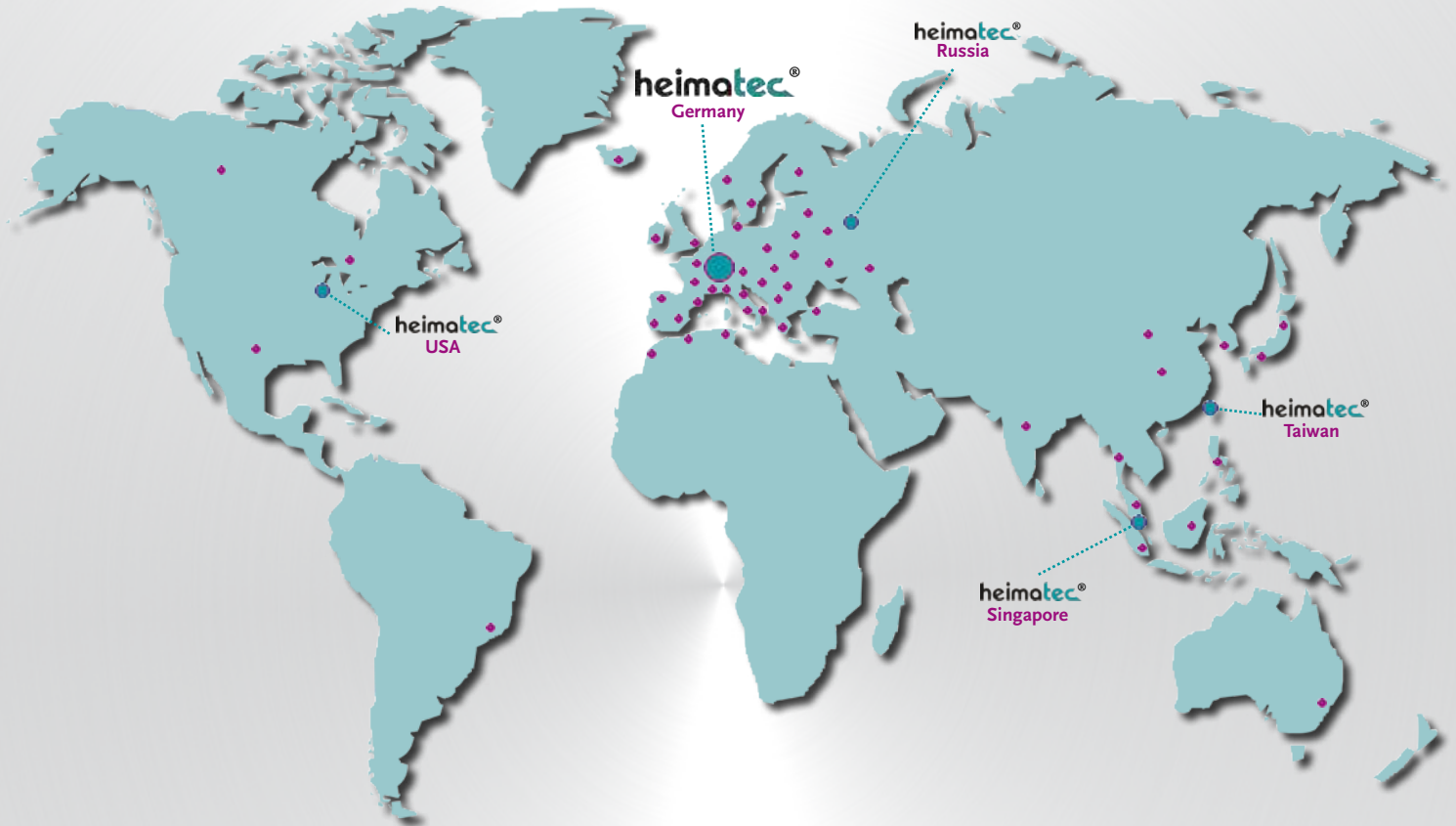

Hauptsitz/headquarters

heimatec® GmbH
Präzisionswerkzeuge
Carl-Benz-Straße 4
D- 77871 Renchen
Postfach 11 36
D- 77867 Renchen
Tel.: +49 (78 43) 94 66 0
Fax: +49 (78 43) 94 66 66
heimatec.de
info@heimatec.de

heimatec® Inc.
USA
usa.heimatec.com
USA@heimatec.com

heimatec®-Ost, JSC
Russia
ru.heimatec.com
Russia@heimatec.com

heimatec® Ltd.
Taiwan
tw.heimatec.com
Taiwan@heimatec.com

heimatec®
Singapore
sg.heimatec.com
Singapore@heimatec.com



Werkzeugkatalog

tool catalogue

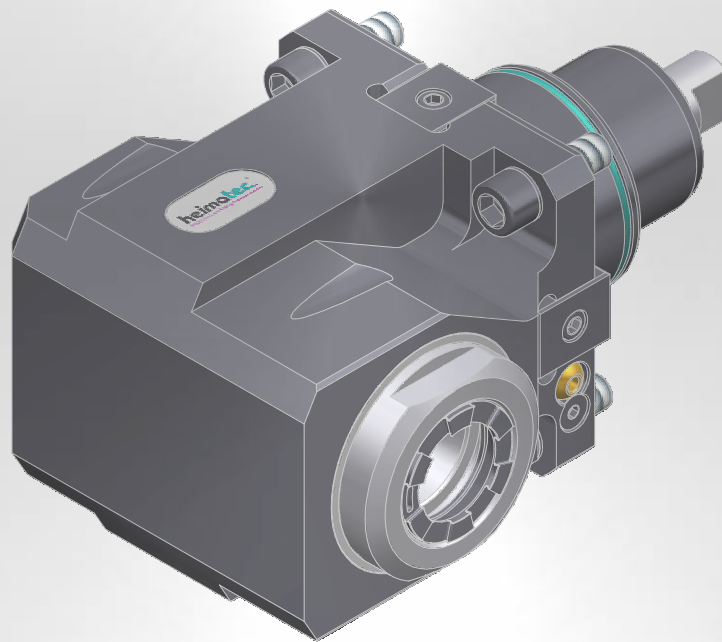

HYUNDAI WIA

LV 800 RM/LM



Hinweis zu den AGBs:

Diese finden Sie in unserem Internetauftritt unter

www.heimatec.de

Home/Impressum/AGB

Terms and conditions:

You will find them on our website

www.heimatec.com

Home/Imprint/Terms and Conditions

Das Katalog-Werk einschließlich aller seiner Teile ist urheberrechtlich geschützt. Jede Verwertung außerhalb der engen Grenzen des Urheberrechtsgesetzes ist ohne Zustimmung der Rechteeinhaber unzulässig und strafbar. Das gilt insbesondere für Vervielfältigungen, Übersetzungen, Mikroverfilmungen und die Einspeicherung und Verarbeitung in elektronischen Systemen.

heimatec® GmbH behält sich Änderungen technischer Art jederzeit ohne Vorankündigung vor. Dies gilt insbesondere bei Anpassungen an neue oder geänderte internationale Normen oder bei Weiterentwicklungen unserer Produkte oder Herstellungsprozesse.

This catalogue, including all its parts, is protected by copyright. Each use outside the restricted limitations of the Copyright Act is inadmissible and liable to prosecution without the consent of heimatec. This is particularly valid for duplication, translation, microfilming and feeding and processing in electronic systems.

heimatec® GmbH reserves the right of technical changes everytime without advance notice, which is particularly valid for adaptions to new or changed international standards, or to developments of our products or manufacturing processes.

angetriebene Werkzeuge
driven tools



Axial-Bohr- und Fräskopf
axial drilling and milling head

$n_{max} = 4000 \text{ min}^{-1}$

8 010 67 059	ER 40 AX u-tec	EK	1:1
8 010 67 039	ER 40 AX u-tec	IK 25 bar	1:1
8 010 67 061	ER 40 AX u-tec	IK 70 bar	1:1
8 010 68 031	easy-quick HT 6	EK	1:1
8 010 68 032	easy-quick HT 6	IK 25 bar	1:1
8 010 68 037	easy-quick HT 6	IK 70 bar	1:1



Axial-Bohr- und Fräskopf
axial drilling and milling head

$n_{max} = 4000 \text{ min}^{-1}$

8 011 65 007	Kombidom/universal arbor 22	EK	1:1
8 011 65 016	Kombidom/universal arbor 1"	EK	1:1



Winkel-Bohr- und Fräskopf
radial drilling and milling head

Mittenmaß / center distance H=90
 $n_{max} = 4000 \text{ min}^{-1}$

8 030 67 074	ER 40 AX u-tec	EK	1:1
8 030 67 071	ER 40 AX u-tec	IK 140 bar	1:1
8 030 68 023	easy-quick HT 6	EK	1:1
8 030 68 022	easy-quick HT 6	IK 140 bar	1:1



Winkel-Bohr- und Fräskopf
radial drilling and milling head

Mittenmaß / center distance H=90
 $n_{max} = 4000 \text{ min}^{-1}$

8 031 65 020	Kombidom/universal arbor 22	EK	1:1
8 031 65 021	Kombidom/universal arbor 1"	EK	1:1

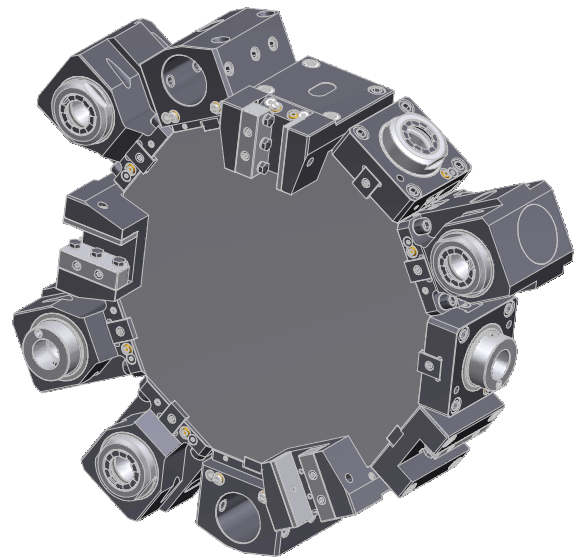

HYUNDAI WIA LV 800 - RM/LM

► Weitere Ausführungen auf Anfrage
further versions on request

► Zubehör **ZB...***
accessories **ZB...***



► **easy-quick**



► **u-tec**



feste Werkzeuge
static tool holders

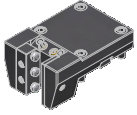

Kombi-Drehstahlhalter
universal turning holder

8 224 26 006	Vierkant/square 32	EK
8 224 26 007	Vierkant/square 1 1/4"	EK



Kombi-Plandrehhalter
combi facing holder

8 244 26 006	Vierkant/square 32	EK
8 244 26 007	Vierkant/square 1 1/4"	EK



Bohrstangenhalter
boring bar holder

Mittenmaß / center distance H=60

8 240 29 016	ø40	IK/EK
8 240 29 018	ø50	IK/EK
8 240 29 008	ø60	IK/EK
8 240 29 022	ø2"	IK/EK
8 240 29 023	ø2 1/2"	IK/EK

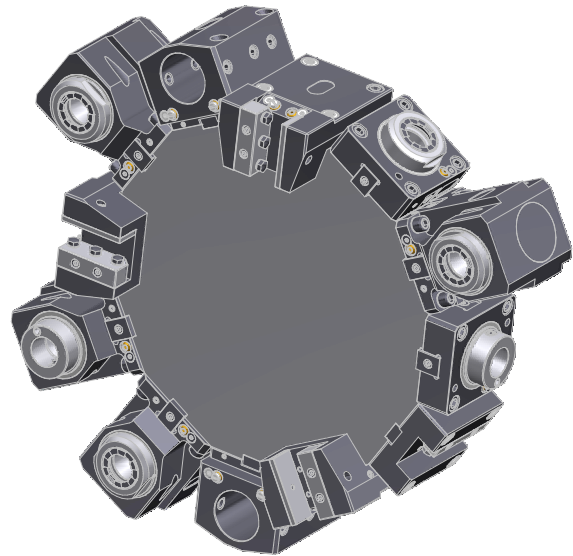

▶ Weitere Ausführungen auf Anfrage
further versions on request

▶ Zubehör **ZB...***
accessories **ZB...***



▶ **easy-quick**



▶ **u-tec**



- ▶ *easy-quick* HT Schnellwechselsystem
easy-quick HT *fast change system*

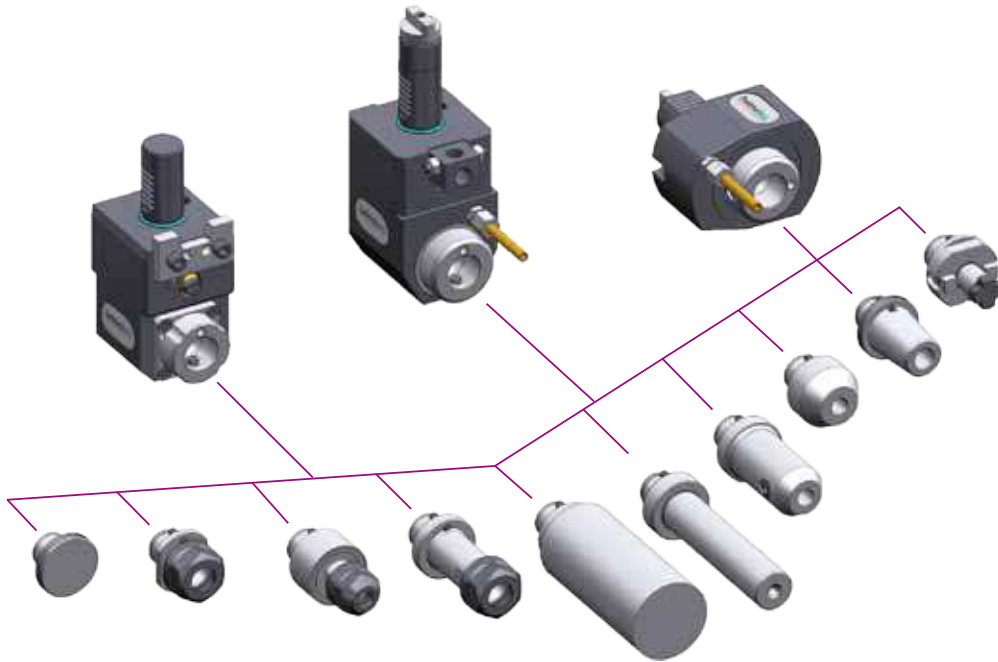

DAS Schnellwechselsystem von heimatec
für angetriebene und feste Werkzeuge

*THE fast change system of heimatec
for driven and static tools*

- ▶ Ausführungen siehe Katalog
versions see catalogue



www.heimatec.de
Produkte / easy-quick

www.heimatec.com
products / easy-quick

► **u-tec[®] UT Wechselsystem**
u-tec[®] UT change system

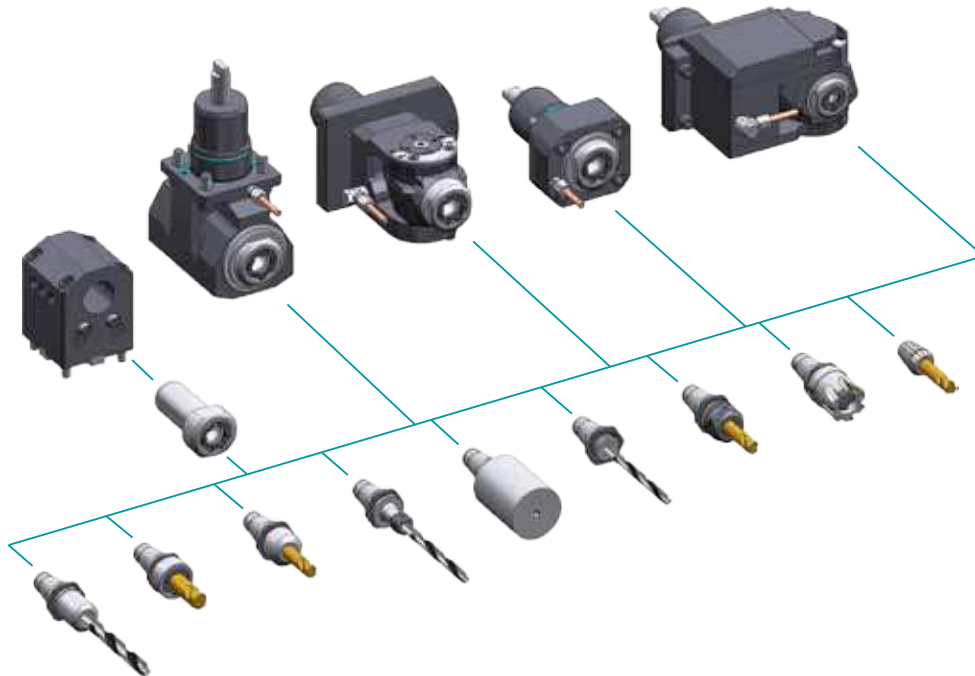

Unser Wechselsystem,
das ALLES möglich macht

Our change system,
that makes EVERYTHING possible

► Ausführungen siehe Katalog
versions see catalogue



www.heimatec.de
Produkte / u-tec

www.heimatec.com
products / u-tec

► **Zubehör**
accessories



► Ausführungen siehe Katalog
versions see catalogue



www.heimatec.de
Produkte / Zubehör

www.heimatec.com
products / accessories

heimatec®

- heimatec®-Niederlassungen
heimatec® overseas branches
- unsere weltweiten Vertretungen
global representations of heimatec®

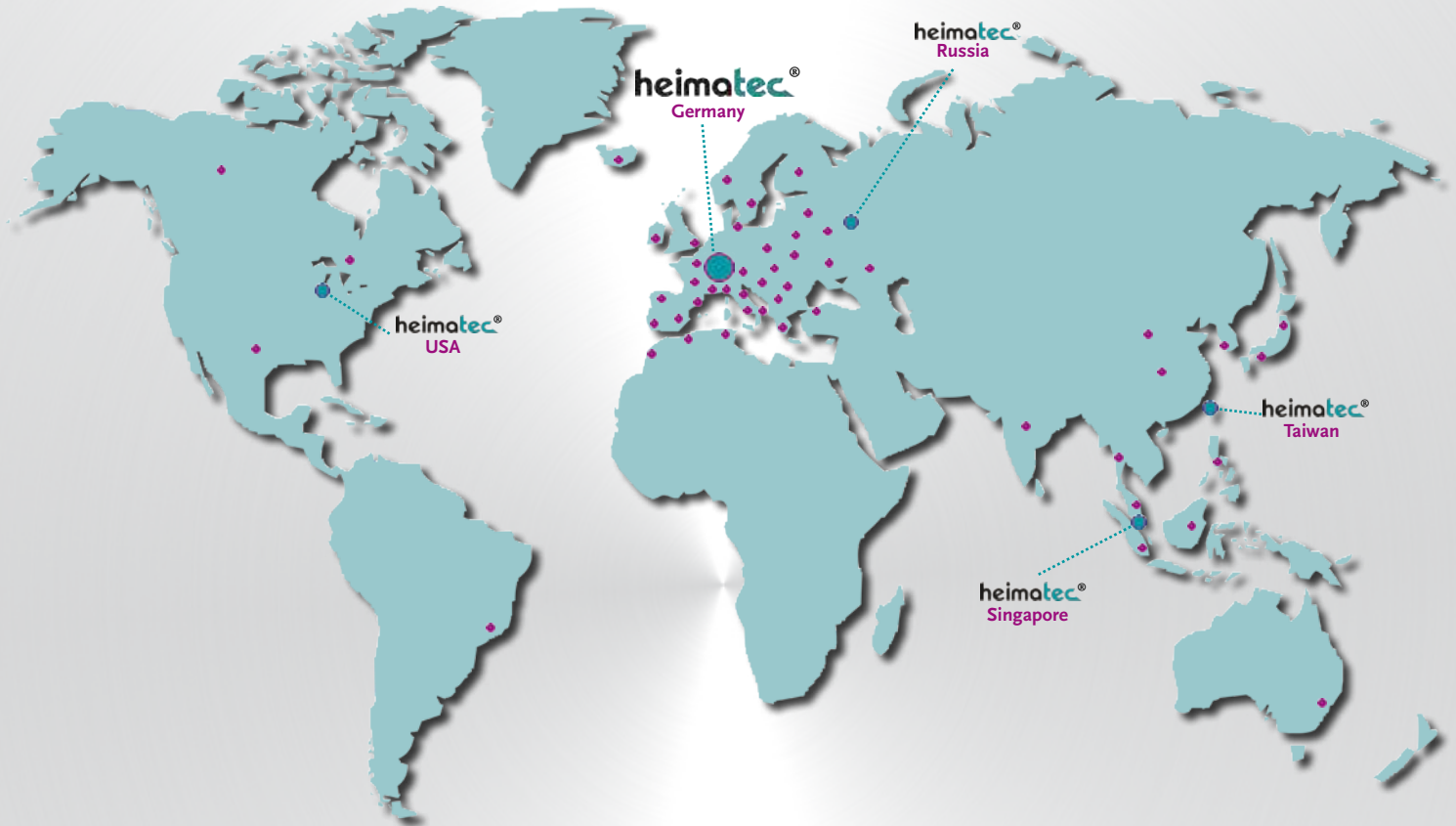

Hauptsitz/headquarters

heimatec® GmbH
Präzisionswerkzeuge
Carl-Benz-Straße 4
D- 77871 Renchen
Postfach 11 36
D- 77867 Renchen
Tel.: +49 (78 43) 94 66 0
Fax: +49 (78 43) 94 66 66
heimatec.de
info@heimatec.de

heimatec® Inc.
USA
usa.heimatec.com
USA@heimatec.com

heimatec®-Ost, JSC
Russia
ru.heimatec.com
Russia@heimatec.com

heimatec® Ltd.
Taiwan
tw.heimatec.com
Taiwan@heimatec.com

heimatec®
Singapore
sg.heimatec.com
Singapore@heimatec.com

